

INSTALLATION AND OPERATION MANUAL

All DC Inverter V8S Series VRF Outdoor Unit

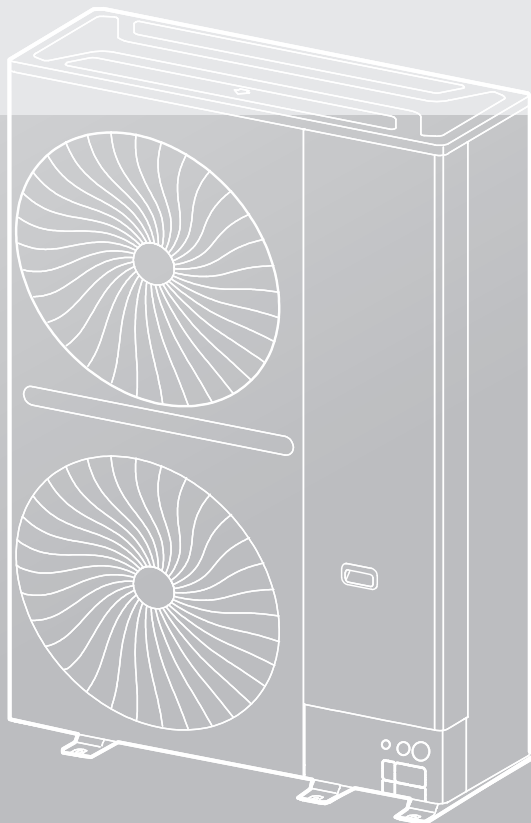

Original instructions
Please read this manual carefully and keep it for future reference.
All the pictures in this manual are for illustration purpose only.

CONTENTS

ABOUT THE DOCUMENTATION	01
SAFETY SIGNS	01
OPERATION	01
1 USER SAFETY INSTRUCTIONS	01
2 SYSTEM INFORMATION	01
3 USER INTERFACE	02
4 BEFORE OPERATION	02
5 OPERATION	02
• 5.1 Operation Range	02
• 5.2 Operating The System	03
• 5.3 Dry Program	03
6 MAINTENANCE AND SERVICE	04
• 6.1 About The Refrigerant	04
• 6.2 After-sales Service And Warranty	04
• 6.3 Maintenance Before Long Shutdown	05
• 6.4 Maintenance After Long Shutdown	05
7 TROUBLESHOOTING	05
• 7.1 Error Code: Overview	07
• 7.2 Symptom: Non Air Conditioning Malfunctions	10
8 RELOCATION	10
9 DISPOSAL	10
INSTALLATION	11
1 OVERVIEW	11
• 1.1 Safety Instructions For Installer	11
• 1.2 Notice	12
2 PACKING BOX	13
• 2.1 Overview	13
• 2.2 Transport	13
• 2.3 Unpack The Outdoor Unit	14
• 2.4 Taking Out Accessories Of Outdoor Unit	14
• 2.5 Layout	14

3	OUTDOOR UNIT COMBINATION	15
•	3.1 Overview	15
•	3.2 Branch Joints	15
•	3.3 Recommended Outdoor Unit Combination	15
4	PREPARATIONS BEFORE INSTALLATION	18
•	4.1 Overview	18
•	4.2 Choosing And Preparing The Installation Site	18
•	4.3 Selecting And Preparing The Refrigerant Piping	20
•	4.4 Selecting And Preparing The Electrical Wiring	27
5	OUTDOOR UNIT INSTALLATION	28
•	5.1 Overview	28
•	5.2 Opening The Unit	28
•	5.3 Mounting The Outdoor Unit	28
•	5.4 Piping Installation	32
•	5.5 Flushing Pipes	36
•	5.6 Gas Tightness Test	36
•	5.7 Vacuum Drying	37
•	5.8 Piping Insulation	37
•	5.9 Refrigerant Charging	38
•	5.10 Electrical Wiring	39
6	CONFIGURATION	47
•	6.1 Overview	47
•	6.2 Digital Displays And Buttons	47
7	COMMISSIONING	53
•	7.1 Overview	53
•	7.2 Precautions When Commissioning	53
•	7.3 Checklist Before Commissioning	53
•	7.4 About Test Run	54
•	7.5 Test Run Implementation	54
•	7.6 Correcting After Abnormal Completion Of Test Run	56
•	7.7 Operating This Unit	56
8	MAINTENANCE AND REPAIR	56
•	8.1 Overview	56
•	8.2 Safety Precautions	56
9	TECHNICAL DATA	56
•	9.1 Dimensions	56
•	9.2 Component Layout And Refrigerant Circuits	57
•	9.3 Outdoor Unit Ducting	59
•	9.4 Fan Performance	59
•	9.5 Erp information	60

ABOUT THE DOCUMENTATION

NOTE

- Make sure that the user has the printed documentation and ask him/her to keep it for future reference.

Target audience

Authorised installers + end users

NOTE

- This appliance is intended to be used by expert or trained users in shops, in light industry, and on farms, or for commercial and household use by lay persons.

WARNING

- Please thoroughly read and ensure that you fully understand the safety precautions (including the signs and symbols) in this manual, and follow relevant instructions during use to prevent damage to health or property.

Documentation set

This document is part of a documentation set. The complete set consists of:

- General safety precautions:
 - Safety instructions that you must read before installing
- Indoor unit installation and operation manual:
 - Installation and operation instructions
- Repeater installation and operation manual:
 - Installation and operation instructions

Technical engineering data

Latest revisions of the supplied documentation may be available via your dealer.

The original documentation is written in English. All other languages are translations.

SAFETY SIGNS

The precautions and things to note in this document involve very important information. Please read them carefully.

DANGER

Indicates a hazard with a high level of risk which, if not avoided, will result in death or serious injury.

WARNING

Indicates a hazard with a medium level of risk which, if not avoided, could result in death or serious injury.

CAUTION

Indicates a hazard with a low level of risk which, if not avoided, could result in minor or moderate injury.

NOTE

A situation that may cause damage to the equipment or loss of property.

INFORMATION

Indicates a useful hint or additional information.

OPERATION

1 USER SAFETY INSTRUCTIONS

- Unit is marked with the following symbols:



DISPOSAL: Do not dispose this product as unsorted municipal waste. Collection of such waste separately for special treatment is necessary.

Do not dispose of electrical appliances as unsorted municipal waste, use separate collection facilities.

Contact your local government for information regarding the collection systems available.

If electrical appliances are disposed of in landfills or dumps, hazardous substances can leak into the groundwater and get into the food chain, damaging your health and well-being.

2 SYSTEM INFORMATION

INFORMATION

The equipment must be operated by professionals or trained people, and it is mainly used for commercial purposes such as stores, shopping malls and large office buildings.

A-weighted sound pressure of all the units level are all below 70 dB.

This unit can be used for heating/cooling.

NOTE

- Do not use the air conditioning system for other purposes. In order to avoid quality degradation, do not use the unit to cool precision instruments, food, plants, animals or works of art.
- For system maintenance and expansion, please contact professional staff.
- The units <V8S Series> are partial unit air conditioners, complying with partial unit requirements of this International Standard, and must only be connected to other units that have been confirmed as complying to corresponding partial unit requirements of this International Standard.

3 USER INTERFACE

CAUTION

- Please contact the dealer if you need to check and adjust the internal components.
- This operation manual only provides information on the main functions of this system.

4 BEFORE OPERATION

WARNING

- This unit consists of electrical components and hot parts (danger of electric shock and scald).
- Before you operate this unit, make sure that the installation personnel have installed it properly.
- This appliance can be used by children aged from 8 years and above and persons with reduced physical, sensory or mental capabilities or lack of experience and knowledge if they have been given supervision or instruction concerning use of the appliance in a safe way and understand the hazards involved.
- Children shall not play with the appliance.
- Cleaning and user maintenance shall not be made by children without supervision.

CAUTION

- The air outlet must not be directed at any human body as it is not conducive to the person's health to be exposed to long periods of moving cold/hot air.
- If the air conditioner is used together with a device that comes with a burner, make sure the room is fully ventilated to prevent anoxia (oxygen insufficiency).
- Do not operate the air conditioner when applying fumigated insecticide in the room. This may cause chemicals to be deposited inside the unit, and pose a danger to the health of people allergic to chemicals. This unit should only be serviced and maintained by a professional air conditioning service engineer. Incorrect servicing or maintenance can cause electric shock, fire or leakage of water. Contact your dealer for servicing and maintenance.
- Cleaning and user maintenance shall not be made by children without supervision.
- The appliance shall be installed in accordance with national wiring regulations.
- This appliance is intended to domestic and used by expert or trained users in shops, in light industry and on farms, or for commercial use by lay persons.

5 OPERATION

5.1 Operation Range

Table 5.1

IDU Type	Common indoor unit		Fresh processing air indoor unit	
	Cooling	Heating	Cooling	Heating
Outdoor temperature	-15~55°C	-30~30°C	20~43°C	-5~16°C
Indoor temperature	16~32°C	15~30°C		
Indoor humidity	≤80% ^(a)			

(a) Condensate might form on the unit's surface if the humidity is above 80%

NOTE

The safety device will be triggered if the temperature or humidity exceeds these conditions, and the air conditioner may not run.

5.2 Operating The System

5.2.1 System operation

The operating program varies with different combinations of outdoor unit and controller.

To protect this unit, turn on the main power supply 12 hours before operation.

If there is a power outage while the unit is running, the unit will automatically restart its operation when the power supply resumes.

5.2.2 Cooling, heating, fan only and auto operations

The indoor units in the air conditioner can be controlled separately, but the indoor units in the same refrigerant system cannot operate in the heating and cooling modes at the same time.

When the cooling and heating modes conflict, the mode is determined based on the setting of the " Menu mode" of the outdoor unit.

Table 5.2

Automatic priority mode	Automatic selection of heating or cooling priority based on the ambient temperature.
Cooling priority mode	When you select the cooling mode as the priority mode, the heating operations in the indoor unit stops running, while the cooling mode will operate as usual;
VIP priority mode or voting priority mode	If the VIP indoor unit has been set and turned on, the operating mode of VIP indoor unit will be regarded as the priority operating mode of the system. If the VIP indoor unit has not been set or not turned on, the mode adopted by most indoor units at the same time will be the priority operating mode of the system.
In response to heating mode only	Indoor units with the heating mode will operate normally, while indoor units in the cooling or fan mode will display the "dd".
In response to cooling mode only	Indoor units in the cooling and fan modes will operate normally, while indoor units in the heating mode will display the "dd".
Heating priority mode	Indoor units in the cooling or fan mode will stop running, while indoor units in the heating mode will run as usual.
Change over	Only applicable to V8 series indoor unit, must set the VIP indoor unit. The operation mode of non-VIP indoor unit cannot be selected by controllers even the outdoor unit is stop running.
Voting priority mode	The mode adopted by most indoor units at the same time will be the priority operating mode of the system.
First on priority mode	The operating mode of the first running Indoor unit will be regarded as the priority operating mode of the system.
Capability requirements priority mode	The mode adopted by the greater demand of indoor units at the same time will be the priority operating mode of the system.

5.2.3 Heating operation

It may take longer to reach the set temperature for general heating operation than for cooling operation.

The following operation is performed in order to prevent the heating capacity from dropping or cold air from blowing

Defrost Operation

In the heating operation, as the outdoor temperature decreases, frost may be formed on the heat exchanger in the outdoor unit, making it more difficult for the heat exchanger to heat up the air. The heating capacity decreases, and a defrosting operation needs to be performed on the system in order for the system to provide sufficient heat to the indoor unit. At this point, the indoor unit will show "dF" on the display screen.

The indoor fan motor will automatically stop running so as to prevent cold air from coming out of the indoor unit when the heating operation starts. This process will take some time. This is not a malfunction.

i INFORMATION

- In heating mode, the air-conditioning system absorbs heat from the outdoor air and releases heat to the indoor side. When the outdoor temperature is low, less heat is released. This is the principle of heat pump.
- When the outdoor temperature is extremely low, the heating capacity of the air conditioner decreases, and other heating equipment may need to be added.

5.2.4 To operate the system

Press the operation mode selector button on the user interface and select the operation mode.

Press the ON/OFF button on the user interface.

Result: The running light turns on and the system starts to run.

Stop

Press the ON/OFF button on the user interface.

Result: The running light is off, and the system stops running.

💡 NOTE

Once the unit has stopped running, do not disconnect the power immediately. Wait for at least 10 minutes.

Adjust

Refer to the user manual for the controller on how to set the required temperature, fan speed and air flow direction.

5.3 Dry Program

5.3.1 System operations

The function in this program uses the minimum temperature drop (minimum indoor cooling) to bring about a drop in humidity in the room.

The temperature and fan speed cannot be set.

6 MAINTENANCE AND SERVICE

NOTE

- Never inspect or service the unit by yourself. Ask a qualified service person to perform this work.

WARNING

- Never replace a fuse with a fuse of a wrong ampere ratings or other wires when a fuse blows out. Use of wire or copper wire may cause the unit to break down or cause a fire.

CAUTION

- Do not insert fingers, rods or other objects into the air inlet or outlet. Do not remove the fan guard. When the fan is rotating at high speed, it will cause injury.
- After a long use, check the unit stand and fitting for damage. If damaged, the unit may fall and result in injury.

WARNING

- When the fuse melts, do not use any unspecified fuse or other wire to replace the original fuse. The use of electrical wires or copper wires may cause the unit to malfunction or cause a fire.
- Do not insert fingers, sticks, or other items into the air inlet or outlet. Do not remove the fan mesh cover. When the fan rotates at a high speed, it may cause bodily injury.
- It is very dangerous to check the unit when the fan is rotating.
- Make sure you turn off the main power switch before any maintenance work begins.
- Do check the supporting and base structure of the unit for any damages after a long period of use. The unit may drop and cause personal injury if there is any damage.

6.1 About The Refrigerant

This product contains fluorinated greenhouse gases as stipulated in the Kyoto Protocol. Do not discharge the gas into the atmosphere.

Refrigerant Type: R410A

GWP Value: 2088

Based on the applicable law, the refrigerant must be checked regularly for leakages. Please contact the installation personnel for more information.

WARNING

- The refrigerant in the air conditioner is safe, and usually does not leak.
- If the refrigerant leaks, and comes in contact with burning objects in the room, it will produce harmful gases. Shut down any flammable heating device, ventilate the room and contact the dealer immediately.
- Do not use the air conditioner again until the maintenance personnel has confirmed that the refrigerant leakage has been sufficiently resolved.

6.2 After-sales Service And Warranty

6.2.1 Warranty period

This product contains the warranty card that was completed by the dealer during installation. The customer must check the completed warranty card and keep it properly.

If you need to repair the air conditioner during the warranty period, please contact the dealer and provide the warranty card.

6.2.2 Recommended maintenance and inspection

As the use of the unit for many years will eventually lead to a dust layer, the performance of the unit will degenerate to a certain extent.

As professional skills are needed to dismantle and clean the unit, and for the optimal maintenance effects of this unit, please contact your dealer for more details.

When you request the dealer for assistance, please remember to state:

- Complete model name of the air conditioner.
- Date of installation.
- Details on the fault symptoms or errors, and any defects.

NOTE

The warranty does not cover the damage caused by dismantling or cleaning of the internal components by unauthorized dealers.

6.3 Maintenance Before Long Shutdown

For example, at the end of winter and summer.

- Run the indoor unit in the fan mode for about half a day to dry the internal parts of the unit.
- Turn off the power supply.
- Clean the air filter and external shell of the unit. Please contact the installation or maintenance personnel to clean the air filter and external shell of the indoor unit. The installation/operation manual of the specialized indoor unit includes maintenance tips and cleaning procedures. Make sure that the clean air filter is installed in its original position.

6.4 Maintenance After Long Shutdown

For example, in early summer or winter.

- Check and remove all objects that may clog the air inlets and outlets of the indoor and outdoor units.
- Clean the air filter and external shell of the unit. Please contact the installation or maintenance personnel. The installation/operation manual of the indoor unit includes maintenance tips and cleaning procedures. Make sure that the clean air filter is installed in its original position.
- Turn on the main power supply 12 hours before this unit is operated in order to ensure that the unit runs smoothly. The user interface is displayed once the power is turned on.

WARNING

- Do not attempt to modify, dismantle, remove, reinstall or repair this unit, as the improper dismantling or installation may result in electric shock or fire. Please contact the dealer.
- If the refrigerant accidentally leaks, make sure that there is no fire around the unit. The refrigerant itself is completely safe, non-toxic and non-flammable, but it will produce toxic gases when it accidentally leaks and comes in contact with flammable substances generated by existing heaters, and burning devices in the room. You must get a qualified maintenance personnel to verify that the point of leakage has been repaired or rectified before you restore the operations of the unit.

7 TROUBLESHOOTING

WARNING

- When any unusual situations arises (burning odour, etc.), stop the unit immediately and turn off the power.
- As a result of a certain situation, the unit has caused damage, an electric shock, or a fire. Please contact the dealer.

The system maintenance must be carried out by a qualified maintenance personnel:

Table 7.1

Symptom	Measures
If a safety device, such as a fuse, circuit breaker or a leakage circuit breaker is triggered frequently or the ON/OFF switch is not working properly.	Turn off the main power switch.
The operating switch is not functioning normally.	Turn off the power supply.
The operating indicator is flickering, and an error code is shown on the screen as well.	Notify the installation personnel and report the error code.

Other than the above-mentioned situations, and where the fault is not obvious, if the system continues to malfunction, carry out the following steps to investigate.

Table 7.2

Symptom	Measures
The system does not run at all.	<p>Check if there is a power failure. Wait for the power supply to be restored. If a power failure occurs when the unit is still running, the system will restart automatically once the power is restored.</p> <p>Check if the fuse is broken or if the circuit breaker is working. If necessary, replace the fuse or reset the circuit breaker.</p>
The system works fine in the fan-only operating mode but stop running once it enters the heating or cooling operation modes.	<p>Check if the air inlets or outlets of the outdoor or indoor units are blocked by any obstacles. Remove the obstacles, and maintain good ventilation in the room.</p>
The system is running but there is insufficient cooling or heating.	<p>Check if the air inlets or outlets of the outdoor or indoor units are blocked by any obstacles.</p> <p>Remove the obstacles, and maintain good ventilation in the room.</p> <p>Check if the filter is blocked (please refer to the "Maintenance" section in the manual of the indoor unit).</p> <p>Check the temperature settings.</p> <p>Check the fan speed settings on the user interface.</p> <p>Check if the doors and windows are open. Close the doors and windows to shut out wind from the external environment.</p> <p>Check if there are too many people in the room when the cooling mode is in operation. Check if the heat source of the room is too high.</p> <p>Check if there is direct sunlight into the room. Use curtains or blinds.</p> <p>Check if the air flow angle is proper.</p>

7.1 Error Codes: Overview

If an error code appears on the unit user, please contact the installation personnel and inform them of the error code, device model, and serial number (you can find the information on the nameplate of this unit).

Table 7.3 Error code

Error code	Error description	Manual restart required
A01	Emergency stop	NO
xA61	Address (x) of the slave unit error	NO
AAx	No.x Inverter module board and main PCB mismatched	NO
xb53	No. x cooling fan error	YES
C13	Outdoor unit address is repeated	NO
C21	Communication error between indoor and master unit	NO
C26	Number of indoor units detected by master unit has decreased or less than the setting amount	NO
C28	Number of indoor units detected by master unit has increased or more than the setting amount	NO
xC31	Communication error of address X slave outdoor unit	NO
C32	Number of slave units detected by master unit has decreased	NO
C33	Number of slave units detected by master unit has increased	NO
xC41	Communication error between main control chip and inverter driver chip	NO
E41	Outdoor ambient temperature sensor (T4) error (open/short)	NO
F31	Plate heat exchanger cooling refrigerant inlet temperature sensor (T6B) error (open/short)	NO
F41	Outdoor heat exchanger temperature sensor (T3) error (open/short)	NO
F51	Plate heat exchanger cooling refrigerant inlet temperature sensor (T6A) error (open/short)	NO
F62	Inverter module temperature (NTC) protection	NO
F63	Non-inductance resistance temperature (Tr) protection	NO
F6A	F62 protection occurs 5 times in 100 minutes	YES
F71	Discharge temperature sensor (T7C) error (open/short)	YES
F72	Discharge temperature (T7C) protection	NO
F75	Compressor discharge insufficient superheat protection	NO
F7A	F72 protection occurs 3 times in 100 minutes	YES
F81	Gas stop-valve temperature sensor (Tg) error (open/short)	NO
F91	Liquid pipe temperature sensor (T5) error (open/short)	NO
FA1	Outdoor heat exchanger inlet temperature sensor (T8) error (open/short)	NO
FC1	Outdoor heat exchanger outlet temperature sensor (TL) error (open/short)	NO
Fd1	Compressor suction temperature sensor (T7) error (open/short)	NO
FL1	T10 outdoor ambient temperature sensor fault (open circuit/short circuit)	YES
P11	High pressure sensor error	NO
P12	Discharge pipe high pressure protection	NO
P13	Discharge pipe high pressure switch protection	NO
P14	P12 error occurs 3 times in 60 minutes	YES
P21	Low pressure sensor error	YES
P22	Suction pipe low pressure protection	NO
P24	Suction pipe low pressure abnormal rise	NO
P25	P22 error occurs 3 times in 100 minutes	YES

xP32	No. (x) compressor high DC bus current protection	NO
xP33	xP32 protection occurs 10 times in 100 minutes	YES
P51	High AC voltage protection	NO
P52	Low AC voltage protection	NO
P53	Phase B and N of the power cable are connected to the opposite protection	YES
P54	DC bus low voltage protection	NO
P55	DC bus ripple over protection	YES
xP56	No. (x) Inverter module DC bus low voltage error	YES
xP57	No. (x) Inverter module DC bus high voltage error	YES
xP58	No. (x) Inverter module DC bus excessively high voltage error	YES
P71	EEPROM error	YES
Pb1	HyperLink overcurrent error	YES
Pd1	Anti-condensation protection	NO
Pd2	Pd1 protection occurs 2 times in 60 minutes	YES
1b01	Electronic expansion valve (EEVA) error	YES
2b01	Electronic expansion valve (EEVB) error	YES
3b01	Electronic expansion valve (EEVC) error	YES
4b01	Electronic expansion valve (EEVE) error	YES
bA1	HyperLink cannot control indoor unit's electronic expansion valve	YES

Note: 'x' is a placeholder for the fan or compressor address, with 1 representing fan A or compressor A and 2 representing fan B or compressor B.

Table 7.4 Installation and commissioning error code

Error code	Error description	Manual restart required
U11	Outdoor unit type setting error	YES
U12	Capacity setting error	YES
U21	The system contains the 1st generation indoor unit or the indoor units address are repeated	YES
U22	Only hydraulic module available for system IDUs	YES
U23	Common IDU and constant temperature and humidity modular AHU in the system	YES
U24	Common IDU and reheat type fresh air modular AHU in the system	YES
U25	Non-common IDU in the system	YES
U26	IDU and ODU mismatch	YES
U31	No test run or unsuccessful test run, please re-enter the test run	YES
U32	Outdoor temperature out of operating range	YES
U33	Indoor temperature out of operating range	YES
U34	Outdoor and indoor temperature out of operating range	YES
U35	Liquid side stop valve is not opened	YES
U37	Gas side stop valve is not opened	YES
U38	No address	YES
U3A	The communication cable is connected incorrectly	YES
U3b	The installation environment is abnormal	YES
U3C	Auto mode error	NO
U41	Common indoor unit exceeds the allowable connection range	YES
U42	Fresh Air Processing indoor unit exceeds the allowable connection range	YES
U43	AHU kit (discharge air temperature control) is out of the allowable connection range	YES
U44	AHU kit (return air temperature control) is out of the allowable connection range	YES
U45	Constant temperature and humidity modular AHU (with outlet air temperature control) combination ratio out of range	YES
U46	Reheat type fresh air modular AHU (with outlet air temperature control) combination ratio out of range	YES
U48	The total capacity of the indoor unit is out of the allowable connection range	YES
U51	Detected more than one outdoor unit in the individual VRF system	YES
U53	Detected different series outdoor units in the same VRF system	YES
U54	Number of MS on heat pump ODU ≥ 1	YES

Table 7.5 Compressor driver error code

Error code	Error description	Manual restart required
1L01	1L1* or 1L2* error occurs 5 times in 60 minutes	YES
1L11	Software overcurrent	NO
1L12	Software overcurrent protection lasting 30s	NO
1L1E	Hardware overcurrent	NO
1L2E	Module overtemperature protection	NO
1L33	Bus voltage drop fault	NO
1L43	The current sampling bias is abnormal	NO
1L45	Motor code mismatch	NO
1L46	IPM protection (FO)	NO
1L47	Module type mismatch	NO
1L4E	EEPROM error	NO
1L51	Out-of-step error	NO
1L52	Locked-rotor protection	NO
1L5E	Startup failed	NO
1L65	IPM short circuit	NO
1L66	FCT test fault	NO
1L6E	Motor phase loss protection	NO
1L71	U-phase upper driver open circuit	NO
1L76	W-phase lower driver open circuit	NO
1LB7	Other check exceptions	NO
1LBE	High voltage switch operation	NO
1LBF	Software certification module failure	NO

Table 7.6 Fan motor error code

Errorcode	Error description	Manual restart required
xJ01	xJ1* or xJ2* error occurs 10 times in 60 minutes	YES
xJ11	Software overcurrent	NO
xJ12	Software overcurrent protection lasting 30s	NO
xJ1E	Hardware overcurrent	NO
xJ2E	Inverter module high temperature protection	NO
xJ33	Bus voltage drop fault	NO
xJ43	The current sampling bias is abnormal	NO
xJ4E	EEPROM error	NO
xJ51	Out-of-step error	NO
xJ52	Locked-rotor protection	NO
xJ5E	Startup failed	NO
xJ6E	Motor phase loss protection	NO
xJBJ	Software certification module failure	NO

Note: 'x' is a placeholder for the fan address, with 1 representing fan A and 2 representing fan B

Table 7.7 Status code

Status code	Code description	Manual restart required
d0x	Oil return running, x represents oil return operation steps	NO
dfx	Defrost running, x represents defrosting operation steps	NO
d11	Outdoor ambient temperature exceeds the upper limit in Heating mode	NO
d12	Outdoor ambient temperature exceeds the lower limit in Heating mode	NO
d13	Outdoor ambient temperature exceeds the upper limit in Cooling mode	NO
d14	Outdoor ambient temperature exceeds the lower limit in Cooling mode	NO
d31	Refrigerant judgment: no result	NO
d32	Refrigerant quantity judgment: significantly excessive	NO
d33	Refrigerant quantity judgment: slightly excessive	NO
d34	Refrigerant quantity judgment: normal	NO
d35	Refrigerant quantity judgment: slightly insufficient	NO
d36	Refrigerant quantity judgment: significantly insufficient	NO
d37	IDU connected to system is not common	NO
d38	Too low proportion of running IDUs	NO
d39	Failed to detect refrigerant amount during backup	NO
d41	System exist no power indoor unit, HyperLink is controlling this indoor unit's valve	NO
d42	Communication error between the outdoor unit and the optional board	NO

7.2 Symptom: Non Air Conditioning Malfunctions

The following fault symptoms are not caused by the air conditioning:

7.2.1 Symptom: System cannot run

Air conditioner does not start immediately after pressing the switch button on the controller. If the operating indicator lights up, the system is working normally. In order to prevent overloading of the compressor, the compressor will start after 3-5 minutes. The same start-up delay occurs after the mode selector is pressed.

7.2.2 Symptom: Fan speed is not consistent with the setting

Even if the fan speed regulation button is pressed, the fan speed does not change. During heating, when the indoor temperature reaches the set temperature, the outdoor unit will shut down, and the indoor unit switches to the quiet fan speed mode. This is to prevent cold air from blowing directly at the room user. The fan speed will not change even when another indoor unit is in heating operation, if the button is pressed.

7.2.3 Symptom: Fan direction is not consistent with the setting

The air direction is not consistent with the user interface display. The air direction does not swing. This is because the unit is controlled by the centralized controller.

7.2.4 Symptom: A unit is emitting white smoke (indoor unit)

When humidity is high during cooling mode, white mist may appear due to the humidity and the temperature difference between the air inlet and outlet.

When the air conditioner is switched to heating mode after defrosting, the IDU discharges the moisture generated from defrosting as steam.

7.2.5 Symptom: A unit is emitting white smoke (indoor unit, outdoor unit)

After the defrosting operation, switch the system to the heating mode. The moisture produced by the defrosting operation will become steam to be discharged out of the system.

7.2.6 Symptom: The air conditioner is producing noise (indoor unit)

A continuous low "hissing" sound is heard when the system is in "Auto", "Cool", "Dry", and "Heat" modes. This is the sound of refrigerant gas flowing through both indoor and outdoor

A "hissing" sound is heard at the start or immediately after stopping operation or defrost operation. This is the noise of refrigerant caused by flow change.

A "zeen" sound is heard immediately after the power supply is turned on. The electronic expansion valve inside an indoor unit starts working and makes the noise. it will reduce in about one minute.

A continuous low "shah" sound is heard when the system is in cooling mode, dry mode or at a stop. When the drain pump (optional accessories) is in operation, this noise is heard.

A "pishi-pishi" squeaking sound is heard when the system stops after heating operation.

Expansion and contraction of plastic parts caused by temperature change make this noise.

A low "sah", "choro-choro" sound is heard while the indoor unit is stopped. When another indoor unit is in operation, this noise is heard. In order to prevent oil and refrigerant from remaining in the system, a small amount of refrigerant is kept flowing.

7.2.7 Symptom: Noise from air conditioner (indoor unit, outdoor unit)

A soft, continuous hissing sound can be heard when the system is in cooling or defrosting operation. This is the sound of the refrigerant gas flowing in the indoor and outdoor units.

A hissing sound is heard the moment the system starts or stops operation or after the defrosting operation has been completed. This is the noise produced when the refrigerant flow is stopped or changed.

7.2.8 Symptom: Noise from air conditioner (outdoor unit)

When the tone of the operating noise changes. This noise is caused by frequency changes.

7.2.9 Symptom: The IDU blows dust

When filter is very dirty, dust may enter the indoor unit and be blown out.

7.2.10 Symptom: The IDU emits odor

The IDU absorbs the odors of rooms, furniture or cigarettes, etc., and disperses the odors during operation.

It is advised to have the air conditioner cleaned and maintained regularly by professional technicians.

7.2.11 Symptom: ODU fan does not run

In the course of operation. Control speed of fan motor to optimize the product operations.

7.2.12 Symptom: Hot air is felt when the indoor unit stops

Several indoor units operating in the same system. When another unit is running, part of the refrigerant will still flow through this unit.

8 RELOCATION

Please contact the dealer to dismantle and reinstall all the units. You need specialized skills and technology to move the units.

9 DISPOSAL

This unit uses hydrogen fluorocarbons. Please contact the dealer when you want to dispose this unit. Based on the requirements of the law, the collection, transportation and disposal of refrigerants must be in accordance with the regulations governing the collection and destruction of hydrofluorocarbons.

INSTALLATION

1 OVERVIEW

1.1 Safety Instructions For Installer

1.1.1 Overview

WARNING

- Make sure the installation, testing and materials used comply with the applicable law.
- Plastic bags should be disposed of properly. Avoid contact by children. Potential risk: Asphyxia.
- Do not touch the refrigerant piping, water piping or internal parts during operations, and when the operation has just been completed. This is because the temperature may be too high or too low. Let them recover to the normal temperature first. Wear protective gloves if you must come in contact with these.
- Do not touch any refrigerant that has accidentally leaked.

CAUTION

- Please wear the appropriate personal protective tools during installation, maintenance or repair of the system (protective gloves, safety glasses, etc.).
- Do not touch the air inlet or aluminum fin of the unit.

NOTE

- Improper installation or connection of equipment and accessories may cause electric shocks, short circuits, leaks, fires, or other damage to the equipment. Use only accessories, equipment and spare parts made or approved by manufacturer.
- Take appropriate measures to prevent small animals from entering the unit. Contact between small animals and electrical components may cause system malfunction, leading to smoke or fire.
- Do not place any object or equipment on top of the unit.
- Do not sit, climb, or stand on the unit.
- Operation of this equipment in a residential environment could cause radio interference.

1.1.2 Refrigerant

WARNING

- During the test, do not exert a force greater than the maximum allowed pressure on the product (as shown on the nameplate).

WARNING

- Take appropriate precautions to prevent refrigerant leakage. If the refrigerant gas leaks, ventilate the area immediately. Possible risk: An excessively high concentration of refrigerant in an enclosed area can lead to anoxia (oxygen deficiency). The refrigerant gas may produce a toxic gas if it comes in contact with fire.
- Refrigerant must be recovered. Do not release it to the environment. Use the vacuum pump to draw the refrigerant out from the unit.

NOTE

- Make sure the refrigerant piping is installed in accordance with the applicable law. In Europe, EN378 is the applicable standard.
- Make sure the piping and connections are not placed under pressure.
- After all the piping connections have been completed, check to make sure there is no gas leak. Use nitrogen to conduct the leak check for gas.
- Do not charge refrigerant before the wiring layout is completed.
- Only charge the refrigerant after the leak tests and vacuum drying have been completed.
- Do not charge more than the specified amount of refrigerant. This is to prevent the compressor from malfunctioning.
- The refrigerant type is clearly marked on the nameplate.
- The unit is charged with refrigerant when it is shipped from the factory. But depending on the piping dimensions and length, the system require additional refrigerant.
- Only use tools specific to the type of system refrigerant to make sure the system can withstand the pressure, and prevent foreign objects from entering the system.

1.1.3 Electricity

WARNING

- Make sure you switch off the power of the unit before you open the electric control box, and access any circuit wiring or components inside. At the same time, this prevents the unit from being accidentally powered up during installation or maintenance work.
- Once you open the cover of the electric control box, do not let any liquid spill into the box, and do not touch the components in the box with wet hands.
- Cut off power supply more than 10 minutes prior to access the electrical parts. Measure the voltage of the main circuit capacitor or electrical component terminals to make sure the voltage is less than 36 V before you touch any circuit component. Refer to the connections and wiring on the nameplate for the master circuit terminals and connections.
- The installation must be completed by professionals, and must comply with local laws and regulations.
- Make sure the unit is earthed, and the earthing must conform to the local law.
- Use only copper core wires for installation.
- Wiring must be carried out in accordance with what is stated in the nameplate.
- The unit does not include a safety switch device. Make sure a safety switch device that can completely disconnect all polarities is included in the installation, and that the safety device can be completely disconnected when there is excessive voltage (such as during a lightning strike).
- Make sure the wiring ends are not subjected to any external force. Do not pull or squeeze the cables and wires. At the same time, make sure the wiring ends are not in contact with the piping or sharp edges of the sheet metal.
- Do not connect the earth wire to public pipes, telephone earth wires, surge absorbers and other places that are not designed for earthing. A gentle reminder that improper earthing may cause electric shock.
- Use a dedicated power supply cord for the unit. Do not share the same power source with other equipment.
- A fuse or circuit breaker must be installed, and these must conform to the local law.
- Make sure an electric leakage protection device is installed to prevent electric shocks or fire. The model specifications and characteristics (anti high-frequency noise characteristics) of the electric leakage protection device are compatible with the unit to prevent frequent tripping.
- Make sure a lightning rod is installed if the unit is placed on the roof or other places that can be easily struck by lightning.

WARNING

- Make sure all terminals of the components are firmly connected before you close the cover of the electric control box. Before you power on and start the unit, check that the cover of the electric control box is tight and secured properly with screws.

Do not let any liquid spill into the electric control box.
- The appliance shall be installed in accordance with national wiring regulations.
- If the supply cord is damaged, it must be replaced by the manufacturer or its service dealer or a similarly qualified person in order to avoid a hazard.
- An all-pole disconnection switch having a contact separation of at least 3mm in all poles should be connected in fixed wiring.
- The dimensions of the space necessary for correct installation of the appliance including the minimum permissible distances to adjacent structures.
- The temperature of refrigerant circuit will be high, please keep the interconnection cable away from the copper tube.

CAUTION

- Do not install the power cord near equipment that is susceptible to electromagnetic interference, such as TV, and radios to prevent interference.
- Use a dedicated power supply cord for the unit. Do not share the same power source with other equipment. A fuse or circuit breaker must be installed, and these must conform to the local law.

INFORMATION

The installation manual is only a general guide on the wiring and connections, and is not specifically designed to contain all information regarding this unit.

1.2 Notice

WARNING

To prevent electric shock or fire:

- Do not wash the electric box of the unit.
- Do not operate the unit with wet hands.
- Do not place any items that contain water on the unit.

CAUTION

- Do not sit, climb, or stand on the unit.

2 PACKING BOX

2.1 Overview

This chapter mainly introduces the subsequent operations after the outdoor unit has been delivered to site and unpacked.

This specifically includes the following information:

- Unbox and handling the outdoor unit.
- Take out the accessories of the outdoor unit.
- Dismantle the transport rack.

Remember the following:

- At the time of delivery, check the unit for any damage. Report any damage immediately to the carrier's claim dealer.
- As far as possible, transport the packaged unit to its final installation site to prevent damage during the handling process.
- Take note of the following items when transporting the unit:



Fragile. Handle with care.



Keep the unit with its front facing upwards so as not to damage the compressor.

- Select the unit transportation path in advance.

2.2 Transport

Lifting method

NOTE

- Do not remove any packaging during lifting. Where the unit is not packed or the package is damaged, use a gasket or package to protect the unit.
- Use a leather belt that can adequately support the weight of the unit, and has a width ≥ 20 mm.
- Images are for reference only. Please refer to the actual product.
- The belt must have enough strength to bear the weight of the unit; keep the machine balanced and ensure the unit is lifted safely and stably.

- Packaged

Please lift in packaged or protected condition, and do not remove any packaging before lifting.

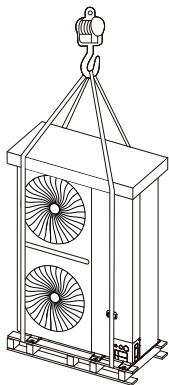

Fig.2.1

- Unpacked

It should be protected by sub-plate showing as Fig.2.2, when the package is damaged.

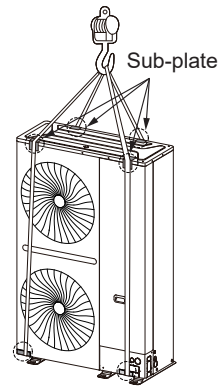

Fig.2.2

Center of gravity position is shown in the following figure 2.3:

Table 2.1

Unit: mm

Model	A	B	C
8-14HP	715	775	267
16-18HP	704	780	286
20-22HP	685	780	281

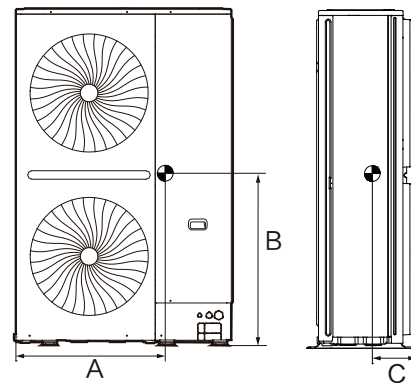

Fig.2.3

- Forklift method

To move the unit with a forklift, insert the forks into the opening at the bottom of the unit, as shown in Figure 2.4.

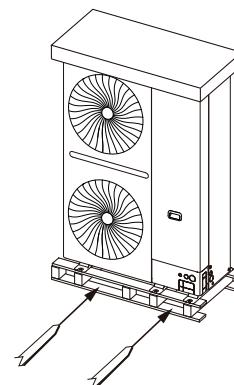

Fig.2.4

2.3 Unpack the Outdoor Unit

Take the unit out from the packing materials:

- Be careful not to damage the unit when you use a cutting tool to remove the wrapping film.
- Remove the six nuts on the wooden back stand.

⚠ WARNING

Plastic film should be disposed of properly.
Avoid contact by children. Potential risk:
Asphyxia.

2.4 Taking Out Accessories Of Outdoor Unit

- The accessories for the unit are stored in two plastic bags. One of the bags stored documents like the manual and the other bag stored the accessories like the pipes. All of them are located inside the unit, near the compressor. The accessories in the unit are as follows:

Table 2.2 Accessories







Name	Qty.	Outline	Function
Owner's and installation manual	1		—
S-shaped pipe connection	2		To connect gas and liquid pipes
Build-out resistance	1		To improve communication stability
Elbow	1		To connect gas pipes
Wrench	1		To remove the side plate screws
Plastic ring	3		To protect power supply cable

Table 2.3

Size	8-14HP		16-22HP	
	Gas pipe	Liquid pipe	Gas pipe	Liquid pipe
L1	70	50	80	50
L2	20	10	20	20
L3	50	75	50	90
L4	70	60	65	80
L5	242	198	253	235
A	25.0	12.7	28.6	16.0
B	25.0	12.7	28.6	16.0
R1	50	25	55	30
R2	50	25	55	30
Thickness	1.2	0.75	1.2	0.75

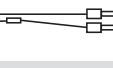
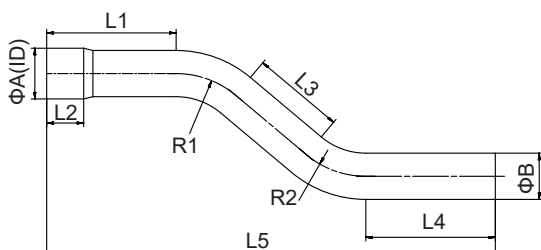

Fig.2.5

2.5 Layout

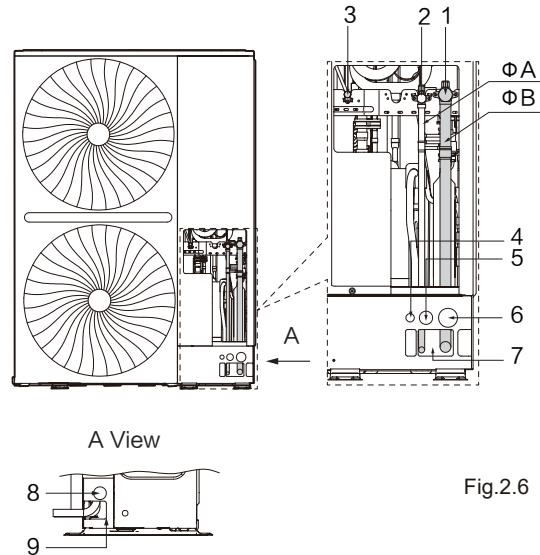

Fig.2.6

Table 2.4

Unit: mm

No.	Name	Function	Size
1	Gas pipe connection port	To connect gas pipes	-
2	Liquid pipe connection port	To connect liquid pipes	-
3	Check port	Used to measure system pressure, charge refrigerant and vacuuming.	-
4	communication wiring holes	communication wiring threading holes for front-direction wiring installation	Φ22.2
5	Reserved cable hole	Reserved threading hole for front-direction wiring installation	Φ35
6	Power cable hole	Power cord threading hole for front-direction wiring installation	Φ50
7	Pipe hole	Pipe-passing window of gas pipe and liquid pipe for front-direction pipe installation	143.9×65
8	Right side cable hole	Power cord threading hole for right-direction pipe installation	Φ50
9	Right side pipe hole	Pipe-passing window of gas pipe and liquid pipe for right-direction pipe installation	89.8×65

Table 2.5

Unit: mm

HP	SIZE	ΦA(OD) (Liquid side)	ΦB(OD) (Gas side)
8-14		Φ12.7	Φ25.4
16-22		Φ15.9	Φ28.6

3 OUTDOOR UNIT COMBINATION

3.1 Overview

This chapter contains the following information:

- List of branch joint fittings.
- Recommended combination for outdoor unit.

3.2 Branch Joints

Table 3.1 For V8 combinable series

Description	Model Name
Outdoor Unit Branch Joint Assembly	FQZHW-02N1E
	FQZHW-03N1E
	FQZHW-04N1G
Indoor Unit Branch Joint Assembly	FQZHN-01D
	FQZHN-02D
	FQZHN-03D
	FQZHN-04D
	FQZHN-05D
	FQZHN-06D
	FQZHN-07D

On the choice of branch joints, refer to section "4.3.3 Piping diameters".

3.3 Recommended Outdoor Unit Combination

CAUTION

- The total capacity of IDU shall be between 50%–130% of the combined capacity of ODU.
- When all indoor units are running at the same time, the total capacity of the indoor units should be less than or equal to the combined capacity of the outdoor unit to prevent overloading in bad working conditions or narrow operating space.
- The total capacity of the indoor units can be up to a maximum of 130% of the combined capacity of the outdoor unit for a system when not all the indoor units are operating at the same time.
- If the system is applied in a cold region (ambient temperature is -10°C or below) or a very hot, heavy loading environment, the total capacity of the indoor units should be less than the combined capacity of the outdoor unit.

Table 3.2 Recommended outdoor unit combination

HP \ HP	8	10	12	14	16	18	20	22	Max Qty. of indoor units
8	●								13
10		●							16
12			●						19
14				●					23
16					●				26
18						●			29
20							●		33
22								●	36
24			● ●						39
26			●	●					43
28				● ●					46
30				●	●				50
32				●		●			53
34					●	●			56
36						● ●			59
38					●			●	63
40						●		●	64
42							●	●	64
44								● ●	64
46				● ●		●			64
48				●	●	●			64
50				●		● ●			64
52					●	● ●			64
54						● ● ●			64
56					●	●		●	64
58						● ●		●	64
60						●	●	●	64
62						●		● ●	64
64							●	● ●	64
66								● ● ●	64

Table 3.2 Recommended outdoor unit combination

HP \ HP	8	10	12	14	16	18	20	22	Max Qty. of indoor units
68				●		● ● ●			64
70				●		● ●	●		64
72						● ● ● ●			64
74						● ● ●	●		64
76						● ● ●		●	64
78						● ●	●	●	64
80						● ●		● ●	64
82						●	●	● ●	64
84						●		● ● ●	64
86							●	● ● ●	64
88								● ● ● ●	64

4 PREPARATIONS BEFORE INSTALLATION

4.1 Overview

This chapter mainly describes the precautions and things to note before the unit is installed at the site.

This mainly includes the following information:

- Choose and Prepare the Installation Site.
- Select and Prepare the Refrigerant Piping.
- Select and Prepare the Electrical Wiring.

4.2 Choosing And Preparing The Installation Site

4.2.1 Site requirements

- Provide sufficient space around the unit for maintenance and air circulation.
- Make sure the installation site can bear the weight of the unit and vibrations.
- Make sure the area is well ventilated.
- Make sure the unit is stable and level.
- Choose a place where the rain can be avoided as much as possible.
- The unit should be installed in a location where the noise generated by the unit will not cause any inconveniences to any person.
- Choose a site that will comply with the applicable law.

Do not install the unit in the following locations:

- An environment where there is a potential risk of explosions.
- Where there are equipment emitting electromagnetic waves. Electromagnetic waves may disrupt the control system, and cause the unit to malfunction.
- Where there are existing fire hazards like leakage of flammable gases, carbon fibers, and combustible dust (such as diluents or gasoline).
- Where corrosive gases (such as sulphurous gases) are produced. Corrosion of copper pipes or welded parts may lead to refrigerant leakage.
- Where mineral oil mist, spray, or steam may exist in the atmosphere. Plastic parts may age, fall off or cause water leakage.
- Where there is a high salt content in the air such as places near the sea.

CAUTION

- Electric appliances that should not be used by the general public must be installed in the safety area to prevent others from getting close to these electric appliances.
- Both indoor and outdoor units are suitable for the installation of commercial and light industrial environment.
- An excessively high concentration of refrigerant in an enclosed area can lead to anoxia (oxygen deficiency).

NOTE

- This is a class A product. This product may cause radio interference in the home environment. The user may need to take the necessary measures if such a situation does arise.
- The unit described in this manual may cause electronic noise generated by radio frequency energy. The unit conforms to the design specifications and provides reasonable protection to prevent such interference. However, there is no guarantee that there will be no interference during a specific installation process.
- Therefore, it is suggested that you install the units and wires at an appropriate distance from devices like sound equipment and personal computers.

- Do take into considerations adverse environmental conditions such as strong winds, typhoons or earthquakes as an improper installation may cause the unit to overturn.
- Take precautions to make sure the water will not damage the installation space and environment in the event of a water leakage.
- If the unit is installed in a small room, refer to section 4.2.3 "Caution for refrigerant leaks" to make sure the refrigerant concentration does not exceed the permissible safety limit when there is a refrigerant leak.
- Make sure the air inlet of the unit is not directed at the main wind direction. Incoming wind will disrupt the operations of the unit. If necessary, use a deflector as an air baffle.
- Add water drain piping on the base so that the condensed water will not damage the unit, and prevent the accumulation of water to form pits when the works are in progress.

4.2.2 Site requirements for installation of outdoor unit in cold regions

NOTE

- Snow protection facilities must be installed in areas with snowfall. Refer to the following figure, (malfunctions are more common when there is insufficient snow protection facilities). In order to protect the unit from accumulated snow, increase the height of the rack, and install a snow shield at the air inlets and outlets.
- Do not obstruct the air flow of the unit when you install the snow shield.

Make note of the following when installing the unit in areas affected by cold weather or snow:

- Avoid direct wind blowing to the air outlet or air inlet

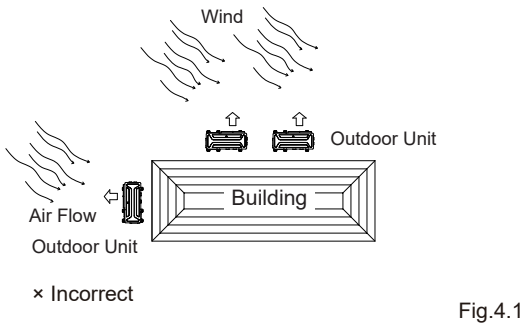
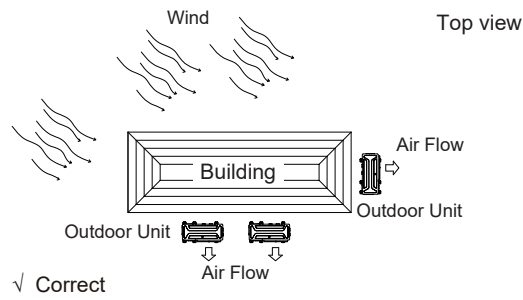

Fig.4.1

- The local maximum snowfall shall be considered when deciding the foundation height of ODU. The foundation or base height of ODU is required to be the expected maximum snowfall thickness $h_0 + 200\text{mm}$, preventing the snow from exceeding the bottom of the unit.

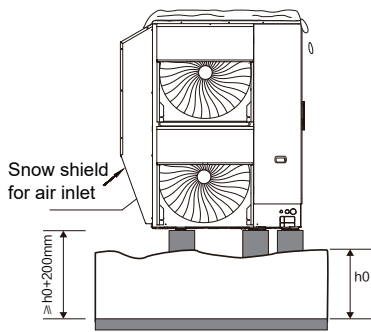

Fig.4.2

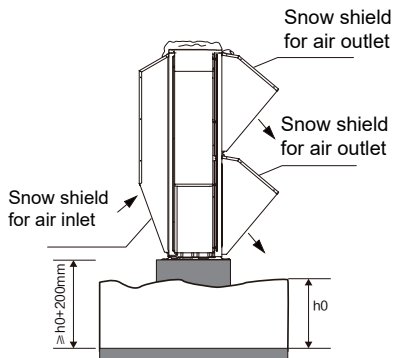

Fig.4.3

- In severe cold areas, longitudinal foundation base shall be used to ensure that drainage is not obstructed. The height of foundation is recommended to be $\geq 500\text{mm}$.

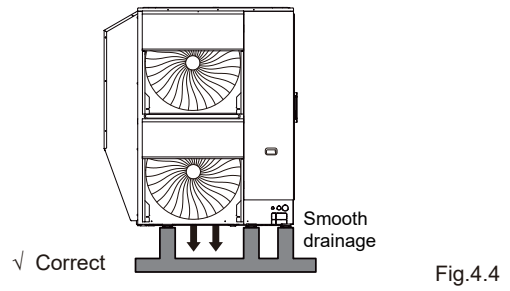

Fig.4.4

- Avoid installation structure to clog the chassis drain holes, the mounting beam should be parallel to the unit to prevent the accumulation of ice and snow.

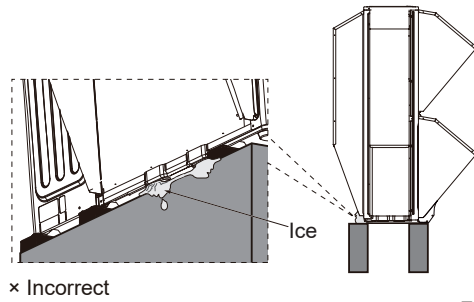

Fig.4.5

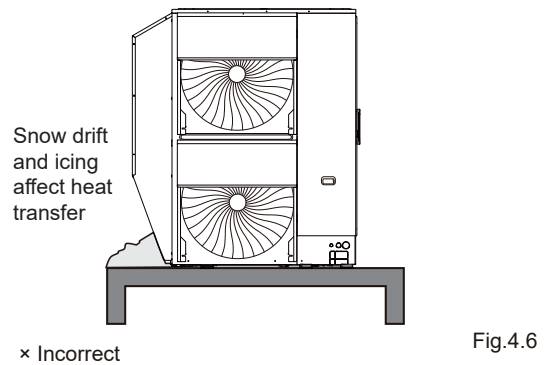

Fig.4.6

- When multiple outdoor units are installed in severe cold areas, they should be arranged side by side. It is forbidden to stack two outdoor units up and down without protection to avoid icing of the outdoor units below.

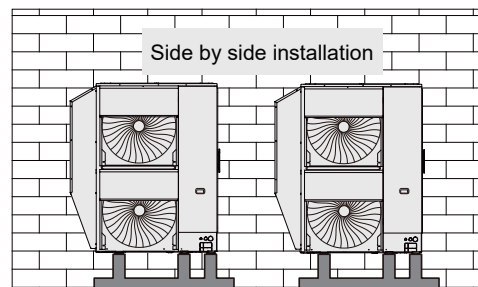

Fig.4.7

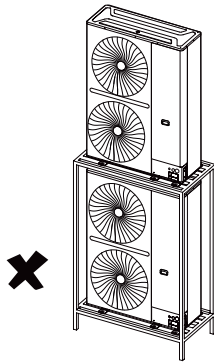

Fig.4.8

4.2.3 Caution for refrigerant leaks

Safety measures

The installation personnel must make sure the safety measures to prevent leaks comply with local regulations or standards. If the local regulations do not apply, the following criteria can be applied. The system uses R410A as the refrigerant. R410A itself is a completely non-toxic, and non-combustible refrigerant. However, do ensure that the air conditioning unit is installed in a room with sufficient space. This is so that when there is a serious leak in the system, the maximum concentration of the refrigerant gas in the room will not exceed the stipulated concentration, and is consistent with the relevant local regulations and standards.

About the maximum concentration level

The calculation for the maximum concentration of the refrigerant is directly related to the occupied space that the refrigerant may leak to and the charging amount of the refrigerant.

The measurement unit for concentration is kg/m³ (weight of gaseous refrigerant that has a volume of 1 m³ in the occupied space).

The highest level of permissible concentration must comply with the relevant local regulations and standards.

Based on the applicable European standards, the maximum permissible concentration level of R410A in the space occupied by humans is limited to 0.44 kg/m³. If this limit is exceeded, necessary measures shall be taken. Please confirm as follows:

- Calculate the total refrigerant charging amount.
Total refrigerant charging amount = refrigerant charging amount of the unit itself + charging amount calculated according to the pipe length.
- Calculate the indoor volume (based on the minimum volume).
- Calculated refrigerant concentration = (total charging amount / indoor volume).

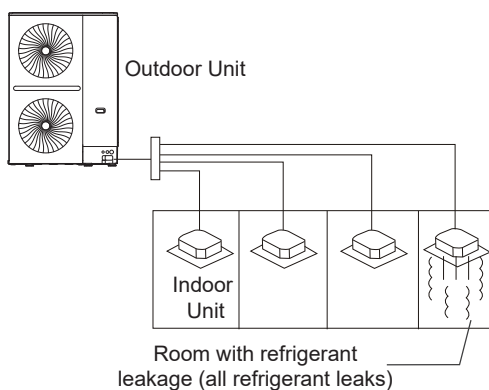

Fig. 4.9

Countermeasures when exceeding the limit concentration
a. Please install a mechanical ventilation device.

- If it is impossible to change air frequently, please install a leak detection alarm device connected with the mechanical ventilation device.

4.3 Selecting And Preparing The Refrigerant Piping

4.3.1 Refrigerant piping requirements

NOTE

The R410A refrigerant pipeline system must be kept strictly clean, dry and sealed.

- Cleaning and drying: prevent foreign objects (including mineral oil or water) from mixing into the system.
- Seal: R410A does not contain fluorine, does not destroy the ozone layer, and does not deplete the ozone layer that protect the earth from harmful ultraviolet radiation. But if it is released, R410A can also cause a slight greenhouse effect. Therefore, you must pay special attention when you check the sealing quality of the installation.
- The piping and other pressure vessels must comply with the applicable laws and suitable for use with the refrigerant. Use only phosphoric acid deoxidized seamless copper for the refrigerant piping.
- Foreign objects in the pipes (including lubricant used during pipe bending) must be ≤ 30 mg/10m.
- Calculate all piping lengths.

4.3.2 Allowable length and height difference for refrigerant piping

Refer to the following table and figure (for reference only) to determine the appropriate size.

NOTE

- The equivalent length of each elbow and U-shape branch joint is 0.5m, the equivalent length of each branch header is 1m.
- As much as possible, install the indoor units such that they are equidistant on both sides of the U-shape branch joint.
- When the outdoor unit is above the indoor unit, and the level difference exceeds 20 m, it is recommended that an oil return bend be set up at every 10 m interval on the gas pipe of the main piping. The recommended specifications of the oil return bend are as shown in figure 4.11.
- The allowable length of the farthest indoor unit to the first branch joint in the system should be equal to or less than 40m unless specified conditions are met, in which case the permitted length is up to 90m. Please refer to requirement 2.
- Special-purpose branch joints from dealer for all branch joints should be used. Failing to do so may lead to severe system malfunction.

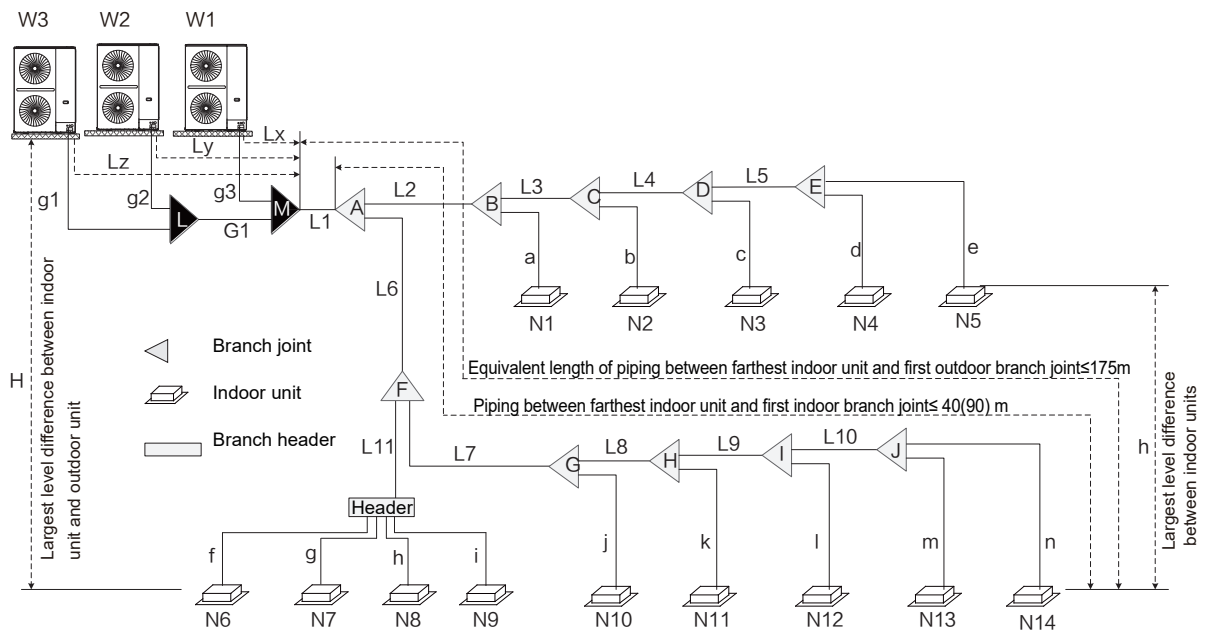

Fig. 4.10

Table 4.1 Pipe and Component Names

Name	Designation	Name	Designation
Outdoor unit connection pipe	g1, g2, g3	Indoor unit main pipe	L2 to L10
Outdoor unit main pipe	G1, G2	Indoor unit branch joint	A to J
Outdoor unit branch joint	L, M	Indoor unit auxiliary connection pipe	a to n
Main pipe	L1		

Table 4.2 Summary of permitted refrigerant piping lengths and level differences

Category		Permitted values	Piping	
Piping lengths	Total piping length	$\leq 560\text{m}$	$L1+L2+L3+L4+L5+L6+L7+L8+\dots+L11+a+b+c+d+e+f+g+h+i+\dots+m+n$	
	Piping between farthest indoor unit and first outdoor branch joint	Actual length	$\leq 150\text{m}$	$L1+L2+L3+L4+L5+e$ or $L1+L6+L7+L8+L9+L10+n$
		Equivalent length	$\leq 175\text{m}$	(Refer to Requirement 1)
	Piping between farthest indoor unit and first indoor branch joint	$\leq 40\text{m}/90\text{m}$	$L2+L3+L4+L5+e$ or $L6+L7+L8+L9+L10+n$	(Refer to Requirement 2)
Piping between outdoor unit and outdoor branch joint	$\leq 10\text{m}$	Lx, Ly, Lz		
Level differences	Largest level difference between indoor unit and outdoor unit	Outdoor unit is above	$\leq 50\text{m}$	H (Refer to Requirement 3)
		Outdoor unit is below	$\leq 40\text{m}$	
	Largest level difference between indoor unit	$\leq 30\text{m}$	h	

The piping length and level difference requirements that apply are summarized in Table 4.2 and are fully described as follows.

- Requirement 1:** The piping between the farthest indoor unit (N14) and the first outdoor branch joint (M) should not exceed 150m (actual length) and 175m (equivalent length). (The equivalent length of each branch joint is 0.5m, and the equivalent length of each branch header is 1m.)
- Requirement 2:** The piping between the farthest indoor unit (N14) and first indoor branch joint (A) should not exceed 40m in length ($\Sigma\{L2 \text{ to } L5\} + e \leq 40\text{m}$ or $\Sigma\{L6 \text{ to } L10\} + n \leq 40\text{m}$) unless the following conditions are met and the following measures are taken, in which case the permitted length is up to 90m.

Conditions:

- Each indoor auxiliary pipe (from each indoor unit to its nearest branch joint) joint does not exceed 40 m in length (a to n each $\leq 40\text{m}$).
- The difference in length between {the piping from first indoor branch joint (A) to the farthest indoor unit (N14)} and {the piping from the first indoor branch joint (A) to the nearest indoor unit (N1)} does not exceed 40m. That is: $(\Sigma\{L6 \text{ to } L10\} + n) - (L2 + a) \leq 40\text{m}$.

Measures:

- Increase the diameter of the indoor gas pipes (the piping between the first indoor branch joint and all other indoor branch joints, L2 to L10) as follows, except for indoor main pipes which are already the same size as the main pipe (L1), for which no diameter increases are required.

Table 4.3 Pipe size allowable increase diameters (mm)

Φ9.52 to Φ12.7	Φ12.7 to Φ15.9	Φ15.9 to Φ19.1
Φ19.1 to Φ22.2	Φ22.2 to Φ25.4	Φ25.4 to Φ28.6
Φ28.6 to Φ31.8	Φ31.8 to Φ38.1	Φ38.1 to Φ41.3
Φ41.3 to Φ44.5	Φ44.5 to Φ50.8	Φ50.8 to Φ54.0

- Requirement 3:** The largest level difference between indoor unit and outdoor unit should not exceed 50m (if the outdoor unit is above) or 40m (if the outdoor unit is below). Additionally: If the outdoor unit is above and the level difference is greater than 20m, it is recommended that an oil return bend with dimensions as specified in Figure 4.11 is set every 10m in the gas pipe of the main pipe.

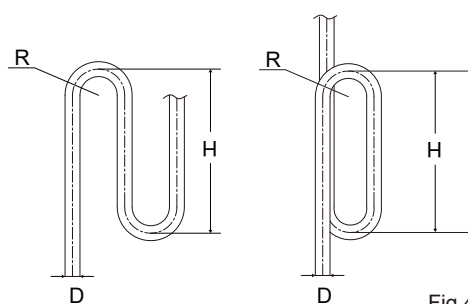

Fig 4.11

Table 4.4

Unit: mm

D	Φ19.1	Φ22.2	Φ25.4	Φ28.6	Φ31.8	Φ38.1
R	≥31		≥45		≥60	
H	≥300					
D	Φ41.3	Φ44.5	Φ50.8	Φ54.0	Φ63.5	
R	≥80			≥90		
H	≥500					

4.3.3 Piping diameter

1) Select the diameter of the main piping

- The main pipe (L1) and first indoor branch joint (A) should be sized according to the Table 4.5 and Table 4.6.

Table 4.5

HP of ODU	Equivalent length between the farthest indoor unit and the first outdoor branch joint < 90m		
	Gas side (mm)	Liquid side (mm)	The first indoor branch joint
8HP	Φ19.1	Φ9.52	FQZHN-01D
10HP	Φ22.2	Φ9.52	FQZHN-02D
12~14HP	Φ25.4	Φ12.7	FQZHN-02D
16HP	Φ28.6	Φ12.7	FQZHN-03D
18~24HP	Φ28.6	Φ15.9	FQZHN-03D
26~34HP	Φ31.8	Φ19.1	FQZHN-03D
36~54HP	Φ38.1	Φ19.1	FQZHN-04D
56~66HP	Φ41.2	Φ19.1	FQZHN-05D
68~82HP	Φ44.5	Φ22.2	FQZHN-05D
84~88HP	Φ50.8	Φ22.2	FQZHN-06D

Table 4.6

HP of ODU	Equivalent length between the farthest indoor unit and the first outdoor branch joint $\geq 90\text{m}$		
	Gas side (mm)	Liquid side (mm)	The first indoor branch joint
8HP	$\Phi 22.2$	$\Phi 12.7$	FQZHN-02D
10HP	$\Phi 25.4$	$\Phi 12.7$	FQZHN-02D
12~14HP	$\Phi 28.6$	$\Phi 12.7$	FQZHN-03D
16HP	$\Phi 31.8$	$\Phi 12.7$	FQZHN-03D
18~24HP	$\Phi 31.8$	$\Phi 15.9$	FQZHN-03D
26~34HP	$\Phi 38.1$	$\Phi 19.1$	FQZHN-04D
36~54HP	$\Phi 41.2$	$\Phi 19.1$	FQZHN-05D
56~66HP	$\Phi 44.5$	$\Phi 22.2$	FQZHN-05D
68~82HP	$\Phi 50.8$	$\Phi 22.2$	FQZHN-06D
84~88HP	$\Phi 54.0$	$\Phi 25.4$	FQZHN-06D

2) Select the branch joint diameters for the indoor unit

Based on the total capacity of the indoor unit, select the branch joint for the indoor unit from the following table.

Table 4.7

Total capacity of indoor units A ($\times 100\text{W}$)	Gas side (mm)	Liquid side (mm)	Branch joint
$A < 168$	$\Phi 15.9$	$\Phi 9.52$	FQZHN-01D
$168 \leq A < 224$	$\Phi 19.1$	$\Phi 9.52$	FQZHN-01D
$224 \leq A < 330$	$\Phi 22.2$	$\Phi 9.52$	FQZHN-02D
$330 \leq A < 470$	$\Phi 28.6$	$\Phi 12.7$	FQZHN-03D
$470 \leq A < 710$	$\Phi 28.6$	$\Phi 15.9$	FQZHN-03D
$710 \leq A < 1040$	$\Phi 31.8$	$\Phi 19.1$	FQZHN-03D
$1040 \leq A < 1540$	$\Phi 38.1$	$\Phi 19.1$	FQZHN-04D
$1540 \leq A < 1900$	$\Phi 41.3$	$\Phi 19.1$	FQZHN-05D
$1900 \leq A < 2350$	$\Phi 44.5$	$\Phi 22.2$	FQZHN-05D
$2350 \leq A < 2500$	$\Phi 50.8$	$\Phi 22.2$	FQZHN-06D
$2500 \leq A < 3024$	$\Phi 50.8$	$\Phi 25.4$	FQZHN-06D
$3024 \leq A$	$\Phi 54.0$	$\Phi 28.6$	FQZHN-07D

If the size of the branch joint pipe selected according to the above table is larger than that of the main pipe according to Table 4.5 or 4.6, the size of the branch joint pipe should be reduced to make it the same as the main pipe.

The pipe thickness of the refrigerant piping shall comply with the applicable legislation.

The minimal pipe thickness for R410A piping must be in accordance with the table below.

Table 4.8

Piping outer diameter (mm)	Minimum thickness (mm)	Temper grade
$\Phi 6.35$	0.80	M-type
$\Phi 9.52$	0.80	
$\Phi 12.7$	1.00	
$\Phi 15.9$	1.00	
$\Phi 19.1$	1.00	
$\Phi 22.2$	1.00	Y2-type
$\Phi 25.4$	1.00	
$\Phi 28.6$	1.00	
$\Phi 31.8$	1.25	
$\Phi 34.9$	1.25	
$\Phi 38.1$	1.50	
$\Phi 41.3$	1.50	
$\Phi 44.5$	1.50	
$\Phi 50.8$	1.80	
$\Phi 54.0$	1.80	

Material: Only seamless phosphorus-deoxidized copper piping that complies with all applicable legislation should be used.

Thicknesses: Temper grades and minimum thicknesses for different diameters of piping should comply with local regulations.

Design pressure of R410 refrigerant is 4.2MPa (42bar).

If the required pipe size is not available, you can use other diameters by considering the following factors:

- In case the standard size is not available in local market, one size up of gas pipe, and one size down of liquid pipe should be used.
- In some conditions, the pipe size needs to be one size up than the standard size that is the "Size up Size" (for example: when the equivalent length between the farthest indoor unit and the first outdoor unit is larger than 90m, the pipe size needs to be one size up; when the piping length from the farthest indoor unit to the first indoor unit is more than 40m, the indoor main pipe size needs to be one size up to allow the piping length up to 90m). In case the "Size up Size" is not available in the local market, the standard size pipe must be used.
- Pipe sizes bigger than corresponding "Size up Size" cannot be used under any circumstances.
- Calculation for the additional refrigerant must be adjusted according to section 5.9 on the determination of the additional refrigerant volume.

3) Select the branch joint diameters for the outdoor unit

Select the branch joint of the outdoor unit from the table below.

Table 4.9

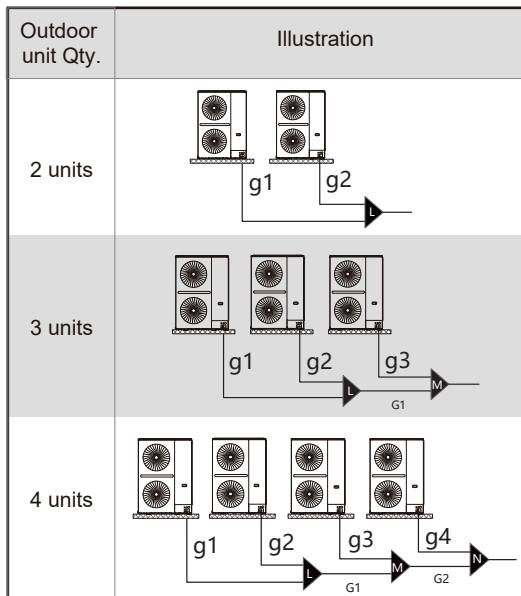

NOTE

For systems with multiple units, the branch joints of the outdoor unit are sold separately.

Table 4.10

Outdoor unit Qty.	Total parallel capacity of outdoor units	Outdoor connection pipes diameter	Branch joint kit
2 units	24~44HP	g1, g2: 8~14HP: Φ25.4/Φ12.7; 16~22HP: Φ28.6/Φ15.9.	L: FQZHW-02 N1E
3 units	46~66HP	g1, g2, g3: 8~14HP: Φ25.4/Φ12.7; 16~22HP: Φ28.6/Φ15.9; G1:Φ38.1/Φ19.1.	L+M: FQZHW-03 N1E
4 units	68~88HP	g1, g2, g3, g4: 8~14HP: Φ25.4/Φ12.7; 16~22HP: Φ28.6/Φ15.9; G1:Φ38.1/Φ19.1; G2:Φ44.5/Φ22.2.	L+M+N: FQZHW-04 N1G

4) Indoor unit auxiliary connection pipe

Table 4.11

Indoor unit capacity A (×100W)	Gas side (mm)	Liquid side (mm)
A≤56	Φ12.7	Φ6.35
56<A≤160	Φ15.9	Φ9.52
160<A≤224	Φ19.1	Φ9.52

CAUTION

- If the indoor unit capacity exceeds the range in the table above, select the pipe diameter according to the manual of the indoor unit.
- The size of indoor side branch pipe shall not be larger than that of main pipe(L1). If the size of main pipe selected according to the above table is larger than that of main pipe, the size of branch pipe shall be reduced to make it the same as that of main pipe.

5) An Example of Refrigerant Piping Selection

The example below illustrates the piping selection procedure for a system consisting of three outdoor units (18HP+18HP+16HP) and 14 indoor units. The system's equivalent length between the farthest indoor unit and the first outdoor branch joint is in excess of 90m; the piping between the farthest indoor unit and the first indoor branch joint is less than 40m in length; and each indoor auxiliary pipe (from each indoor unit to its nearest branch joint) is less than 10m in length.

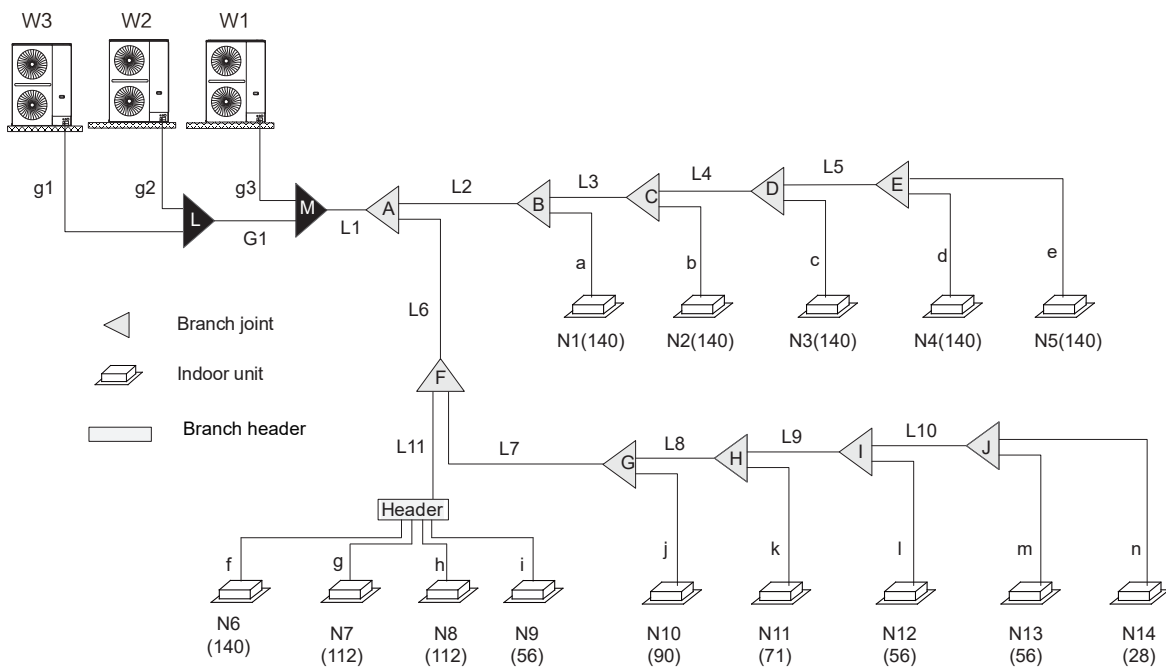

Fig. 4.12

Select the indoor auxiliary connection pipes (a to n)

- The capacity of indoor units N1 to N8, N10 and N11 is larger than 5.6kW, so indoor auxiliary connection pipe a to I is $\Phi 15.9 / \Phi 9.52$.
- The capacity of indoor units N9, N12 to N14 is equal or less than 5.6kW, so indoor auxiliary connection pipe a to I is $\Phi 12.7 / \Phi 6.35$.

Select indoor main pipes L2 to L10 and indoor branch joints B to J

- The indoor units (N1 to N5) downstream of indoor branch joint B have total capacity of $14 * 5 = 70\text{kW}$. Refer to Table 4.7. Indoor main pipe L2 is $\Phi 28.6 / \Phi 15.9$. Indoor branch joint B is FQZHN-03D.
- The indoor units (N2 to N5) downstream of indoor branch joint C have total capacity of $14 * 4 = 56\text{kW}$. Refer to Table 4.7. Indoor main pipe L3 is $\Phi 28.6 / \Phi 15.9$. Indoor branch joint C is FQZHN-03D.
- The indoor units (N3 to N5) downstream of indoor branch joint D have total capacity of $14 * 3 = 42\text{kW}$. Refer to Table 4.7. Indoor main pipe L4 is $\Phi 28.6 / \Phi 12.7$. Indoor branch joint D is FQZHN-03D.
- The indoor units (N4 and N5) downstream of indoor branch joint E have total capacity of $14 * 2 = 28\text{kW}$. Refer to Table 4.7. Indoor main pipe L5 is $\Phi 22.2 / \Phi 9.52$. Indoor branch joint E is FQZHN-02D.
- The indoor units (N6 to N14) downstream of indoor branch joint F have total capacity of $14 + 11.2 * 2 + 9 + 7.1 + 5.6 * 3 + 2.8 = 72.1\text{kW}$. Refer to Table 4.7. Indoor main pipe L6 is $\Phi 31.8 / \Phi 19.1$. Indoor branch joint F is FQZHN-03D.
- The indoor units (N10 to N14) downstream of indoor branch joint G have total capacity of $2.8 + 5.6 * 2 + 7.1 + 9 = 30.1\text{kW}$. Refer to Table 4.7. Indoor main pipe L7 is $\Phi 22.2 / \Phi 9.52$. Indoor branch joint G is FQZHN-02D.

- The indoor units (N11 to N14) downstream of indoor branch joint H have total capacity of $2.8 + 5.6 * 2 + 7.1 = 21.1\text{kW}$. Refer to Table 4.7. Indoor main pipe L8 is $\Phi 19.1 / \Phi 9.52$. Indoor branch joint H is FQZHN-01D.
- The indoor units (N12 to N14) downstream of indoor branch joint I have total capacity of $2.8 + 5.6 * 2 = 14\text{kW}$. Refer to Table 4.7. Indoor main pipe L9 is $\Phi 15.9 / \Phi 9.52$. Indoor branch joint I is FQZHN-01D.
- The indoor units (N13 and N14) downstream of indoor branch joint J have total capacity of $2.8 + 5.6 = 8.4\text{kW}$. Refer to Table 4.7. Indoor main pipe L10 is $\Phi 15.9 / \Phi 9.52$. Indoor branch joint J is FQZHN-01D.
- The indoor units (N6 to N9) downstream of indoor branch header have total capacity of $14 + 11.2 * 2 + 5.6 = 42\text{kW}$. Refer to Table 4.7. Indoor main pipe L11 is $\Phi 28.6 / \Phi 12.7$. Indoor branch header is 1 to 4.

Select main pipe and indoor branch joint A

- The indoor units (N1 to N14) downstream of indoor branch joint A have total capacity of $14 * 6 + 11.2 * 2 + 9 + 7.1 + 5.6 * 3 + 2.8 = 142.1\text{kW}$. The system's equivalent length between the farthest indoor unit and the first outdoor branch joint is in excess of 90m. The total capacity of the outdoor units is $14 + 14 + 24 = 52\text{HP}$. Refer to Table 4.6 and 4.7.
- Main pipe L1 Refer to Table 4.6 is $\Phi 41.3 / \Phi 19.1$. Indoor branch joint A Refer to Table 4.7 is FQZHN-05D.

Select outdoor connection pipes and outdoor branch joints

- The master unit is 18HP and the slave one unit is 18HP and the slave two unit is 16HP. Refer to Table 4.10. Outdoor connection pipes g1 is $\Phi 28.6 / \Phi 15.9$, g2 is $\Phi 28.6 / \Phi 15.9$, g3 is $\Phi 28.6 / \Phi 15.9$. Outdoor connection pipe G1 is $\Phi 38.1 / \Phi 19.1$.
- There are three outdoor units in the system. Refer to Table 4.10. Outdoor branch joints L and M are FQZHW-03N1E.

4.3.4 Arrangement and Layout of Multiple Outdoor Units

- The piping between the outdoor units must be level with the pipes outlet of outdoor units.

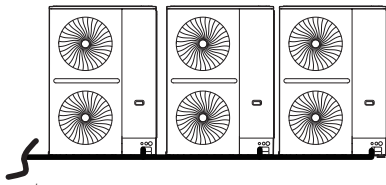

√ Correct

Fig. 4.13

- The piping between the outdoor units must be level and lower than the outdoor unit piping connection.

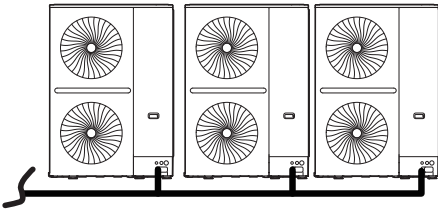

√ Correct

Fig. 4.14

- Branch lower than the outdoor unit piping connection and the direction inclination angle is between 0~15°

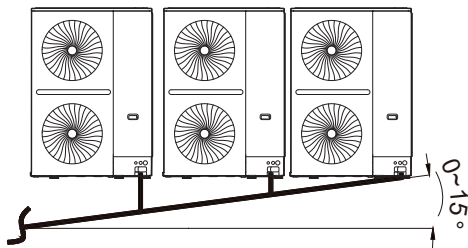

√ Correct

Fig. 4.15

- When there are multiple outdoor units, the branch joints cannot be stood up immediately after connecting the refrigerant piping.

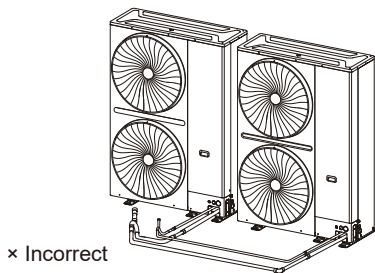

× Incorrect

Fig. 4.16

- The piping connecting the outdoor units must not be higher than the refrigerant outlets.

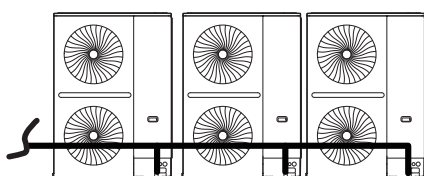

× Incorrect

Fig. 4.17

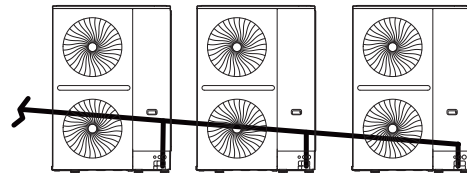

× Incorrect

Fig. 4.18

In case that the piping length between outdoor units is 2m or more, the oil trap for the gas pipe should be provided so that accumulation of refrigerant oil may not occur.

- Less than 2m

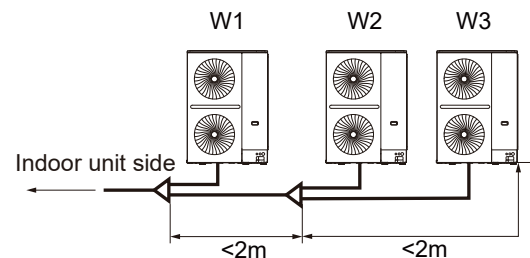

Fig. 4.19

- 2m or more

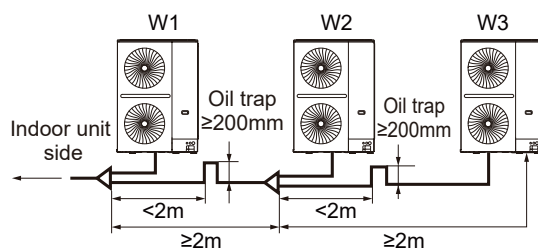
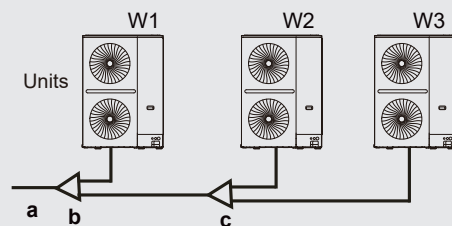

Fig. 4.20

NOTE

In systems with multiple outdoor units, the units should be placed in order from largest capacity unit to smallest capacity unit. The largest capacity unit must be placed on the first branch, and be set as the master unit, while the others should be set as slave units. The capacity of outdoor units W1, W2 and W3 must meet the following conditions: $W1 \geq W2 \geq W3$.



a To indoor unit

b Outdoor branch joint assembly (first branch joint)

c Outdoor branch joint assembly (second branch joint)

4.4 Selecting and Preparing the Electrical Wiring

4.4.1 Electrical compliance

This equipment conforms to: EN/IEC 61000-3-12 specifications which states that the short circuit capacity (of the power supply), Ssc, is greater than or equal to the minimum Ssc value of the interface point between the user's power supply and the public system.

The installation personnel or users have the responsibility to consult the distribution network operators when necessary to ensure that the equipment only connects to a power supply with short circuit capacity, Ssc, greater than or equal to the minimum Ssc value.

Table 4.12

Capacity	Minimum Ssc value(kW)
8HP	4122
10HP	5092
12HP	5577
14HP	6789
16HP	7274
18HP	8001
20HP	9699
22HP	10911

Note:

The European / international technical standards specified a harmonic current limit for devices connected to a public low-voltage system where the input current of each phase > 16 A and ≤ 75 A.

Table 4.14

System	Outdoor Unit				Power Current			Compressor		Fan Motor	
	Voltage (V)	Frequency (Hz)	Min. (V)	Max. (V)	MCA (A)	TOCA (A)	MFA (A)	MSC (A)	RLA (A)	Power (kW)	FLA (A)
8HP	380-415	50/60	342	456	17.0	32.8	20	-	23.5	0.2+0.2	0.65+0.65
10HP	380-415	50/60	342	456	21.0	32.8	25	-	23.5	0.2+0.2	0.65+0.65
12HP	380-415	50/60	342	456	23.0	32.8	32	-	25.2	0.2+0.2	0.65+0.65
14HP	380-415	50/60	342	456	28.0	32.8	32	-	27.2	0.2+0.2	0.65+0.65
16HP	380-415	50/60	342	456	30.0	43.0	40	-	30.5	0.56+0.56	2.0+2.0
18HP	380-415	50/60	342	456	33.0	43.0	40	-	30.5	0.56+0.56	2.0+2.0
20HP	380-415	50/60	342	456	40.0	52.0	50	-	37.5	0.56+0.56	2.0+2.0
22HP	380-415	50/60	342	456	45.0	52.0	50	-	38.5	0.56+0.56	2.0+2.0

i INFORMATION

Phase and frequency of power supply system: 3N~ 50Hz, Voltage: 380-415V

Abbreviations:

MCA: Minimum Circuit Amps; TOCA: Total Over-current Amps; MFA: Maximum Fuse Amps; MSC: Maximum Starting Current (A); RLA: Rated Load Amps; FLA: Fan Load Amps.

- Units are suitable for use on electrical systems where voltage supplied to unit terminals is not below or above listed range limits. Maximum allowable voltage variation between phases is 2%.
- Select wire size based on the value of MCA.
- TOCA indicates the total overcurrent amps value of each OC set.
- MFA is used to select overcurrent circuit breakers and residual-current circuit breakers.
- MSC indicates the maximum current on compressor start-up in amps.
- RLA is based on the following conditions: indoor temperature 27°C DB, 19°C WB; outdoor temperature 35°C DB.

4.4.2 Safety device requirements

1. Select the wire diameters(minimum value) individually for each unit based on the table 4.13 and table 4.14, where the rated current in table 4.13 means MCA in table 4.14. In case the MCA exceeds 63A, the wire diameters should be selected according to the national wiring regulation.
2. Maximum allowable voltage range variation between phases is 2%.
3. Select circuit breaker that having a contact separation in all poles not less than 3 mm providing full disconnection, where MFA is used to select the current circuit breakers and residual current operation breakers:

Table 4.13

Rated current of appliance (A)	Nominal cross-sectional area (mm ²)	
	Flexible cords	Cable for fixed wiring
≤ 3	0.5 and 0.75	1 to 2.5
> 3 and ≤ 6	0.75 and 1	1 to 2.5
> 6 and ≤ 10	1 and 1.5	1 to 2.5
> 10 and ≤ 16	1.5 and 2.5	1.5 to 4
> 16 and ≤ 25	2.5 and 4	2.5 to 6
> 25 and ≤ 32	4 and 6	4 to 10
> 32 and ≤ 50	6 and 10	6 to 16
> 50 and ≤ 63	10 and 16	10 to 25

5 OUTDOOR UNIT INSTALLATION

5.1 Overview

This chapter includes the following information:

- Open the unit
- Outdoor unit installation
- Welding refrigerant piping
- Refrigerant piping check
- Refrigerant charging
- Electrical Wiring

5.2 Opening The Unit

5.2.1 Opening the outdoor unit

- Removal of all screws on the right front side plate; Put the left hand into the handle position to prevent the right front side plate from falling, and prepare for pulling out;
- Press the right hand on the corner of the right front side plate and pull it down, and pull the left hand outward at the same time;
- After the top rib comes out of the top cover, take out the right front side plate.

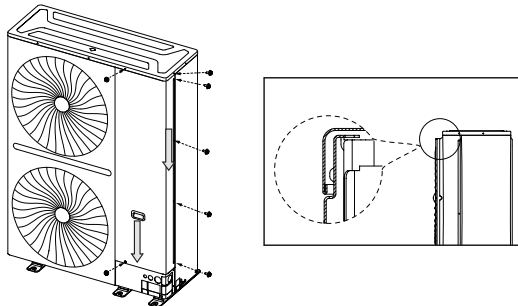

Fig. 5.1

5.3 Mounting The Outdoor Unit

5.3.1 Preparing the structure for installation

- The base of the outdoor unit must use the solid concrete surface as the cement base or the steel beam frame base.
- The base must be completely level to ensure that every point of contact is even.
- During installation, make sure the base supports the vertical folds of the front and back under plates of the chassis directly as the vertical folds of the front and back under plates are unit where the actual support for the unit load is.
- No gravel layer is required when the base is built on the roof surface, but the sand and cement on the concrete surface must be level, and the base should be chamfered along the edge.
- A water drainage ditch should be set around the base to drain the water around the equipment. Potential risk: slip.
- Check the load-bearing capacity of the roof to make sure it can support the load.

- When you choose to install the piping from the bottom, the base height should be above 200mm.
- Make sure the base where the unit is installed is strong enough to prevent vibrations and noise.

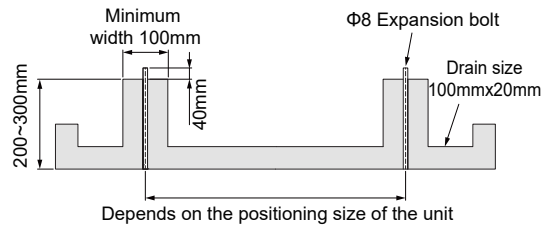

Fig 5.2

Use six bolts (M8) to secure the unit in place. Best is to screw in the ground bolt until it is embedded in the base surface by at least 3 threads.

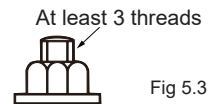

Fig 5.3

Please refer to the figure below for the installation position of bolts.

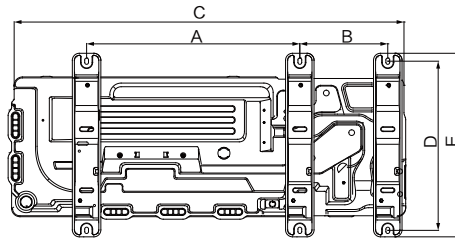

Fig 5.4

Table 5.1

Unit: mm

HP	Size	A	B	C	D	E
8-14HP		614	278	1130	534	580
16-22HP		674	278	1250	534	580

5.3.2 Outdoor unit installation space

Make sure there is sufficient space around the unit for maintenance work, and the minimum space for air inlet and air outlet is reserved (see below to select a feasible method).

NOTE

- In all installation examples in this chapter, the direction of connecting pipe for outdoor unit installation is forward or downward.
- When the rear pipe is connected and installed, the installation space on the right side of the outdoor unit shall be at least 250mm;
- When two or more outdoor units are installed side by side, the distance between two adjacent outdoor units must be greater than 200mm;
- For the installation space of the unit, the maintenance space and smooth ventilation of the unit shall be considered, and an installation method shall be selected according to the actual situation.

There are obstacles on the air inlet side but no obstacles on the air outlet side.

- No obstacles above the outdoor unit;
Unit:mm

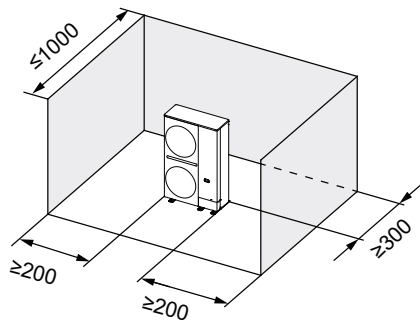

One outdoor unit

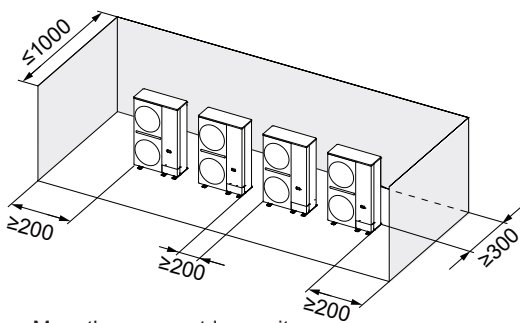

More than one outdoor unit

Fig. 5.5

- There are obstacles above the outdoor unit;
Unit:mm

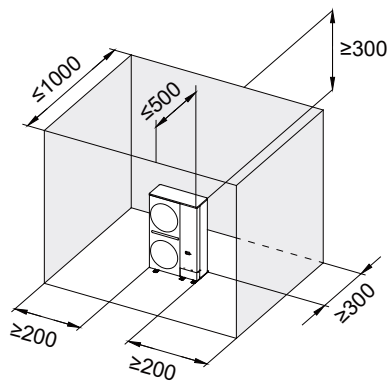

One outdoor unit

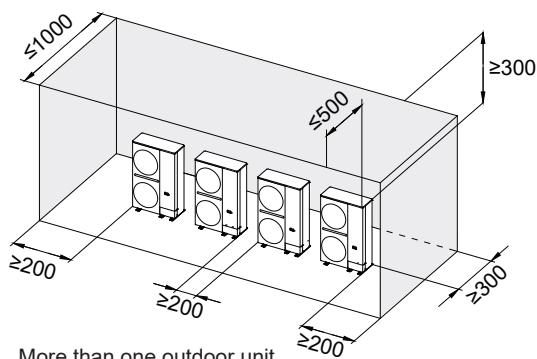

More than one outdoor unit

Fig. 5.6

NOTE

- When the outdoor unit is installed in the space with three ring walls or walls above at the same time, the length of the left and right walls of the machine shall not exceed 1000mm, otherwise the flexible air duct shall be added to guide the air.

There are obstacles on the air outlet side but no obstacles on the air inlet side

- No obstacles above the outdoor unit;
Unit:mm

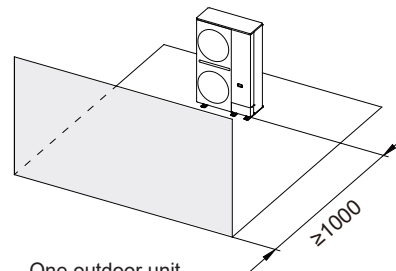

One outdoor unit

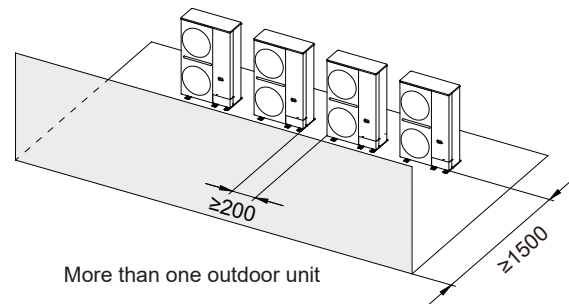

More than one outdoor unit

Fig. 5.7

- There are obstacles above the outdoor unit;
Unit:mm

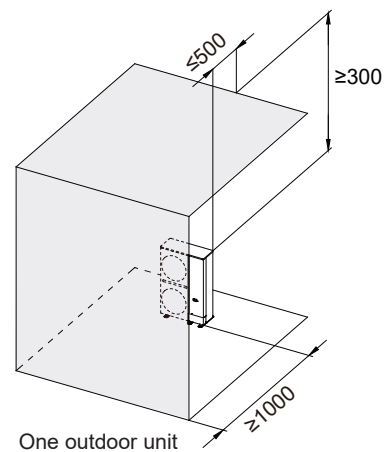

One outdoor unit

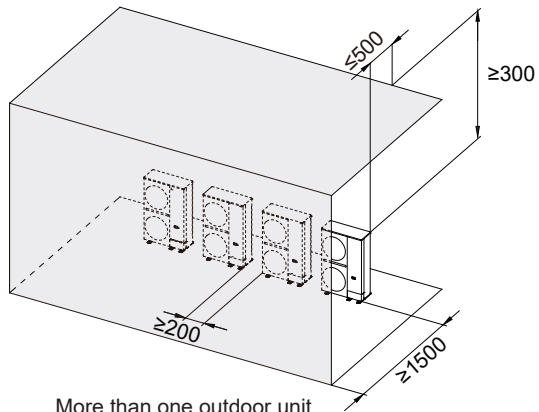

More than one outdoor unit

Fig. 5.8

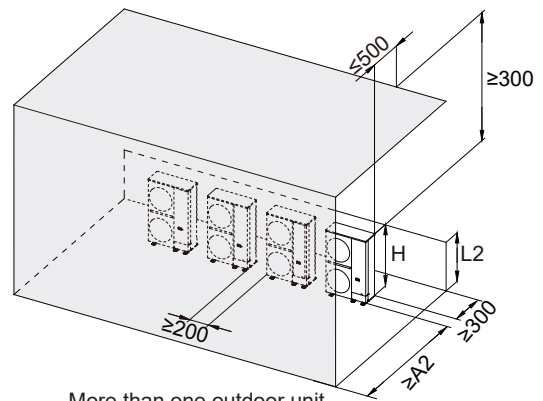

More than one outdoor unit

Fig. 5.10

There are obstacles on both the air outlet side and the air inlet side

- No obstacles above the outdoor unit

Unit:mm

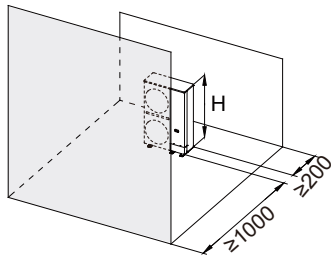

One outdoor unit

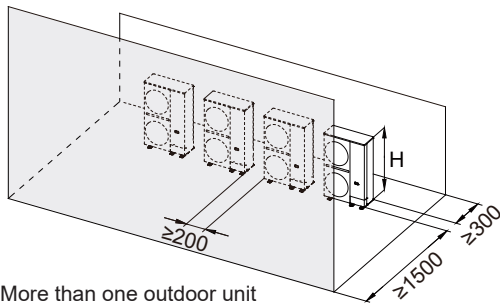

More than one outdoor unit

Fig. 5.9

- There are obstacles above the outdoor unit

Unit:mm

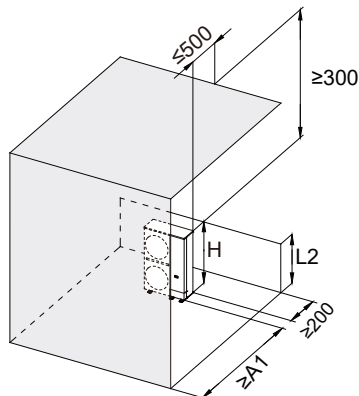

One outdoor unit

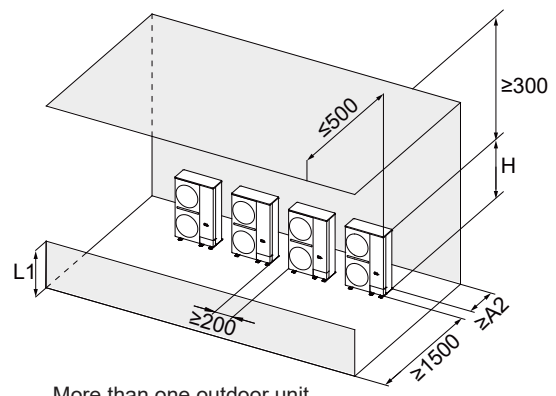

More than one outdoor unit

Fig. 5.11

Table 5.2

Condition	L2	A1	A2
$L2 \leq H$	$0 < L2 < 1/2H$	1000	1500
	$1/2H \leq L2 \leq H$	1250	1750
$L2 > H$	Install air duct to exhaust the air out of the space.		

There are obstacles above the outdoor unit and the height of the obstacles on the air outlet side is lower than that of the outdoor unit.

Unit:mm

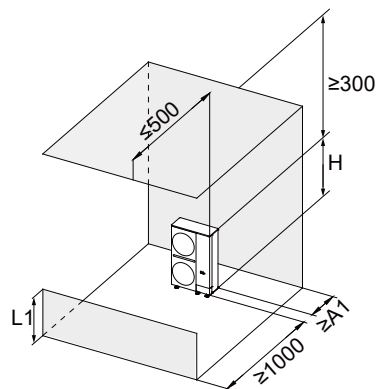

One outdoor unit

Table 5.3

Condition	L2	A1	A2
L1 ≤ H	0 < L1 < 1/2H	200	300
	1/2H ≤ L1 ≤ H	300	450
L1 > H	Install air duct to exhaust the air out of the space.		

Stacking installation

NOTE

- Only 2-layer stack installation is allowed.
- When this installation method is adopted, the upper outdoor unit needs to be provided with centralized drainage.
- Stacking installation is prohibited in severe cold areas.

- Only the air inlet side of the outdoor unit has obstacles:

Unit:mm

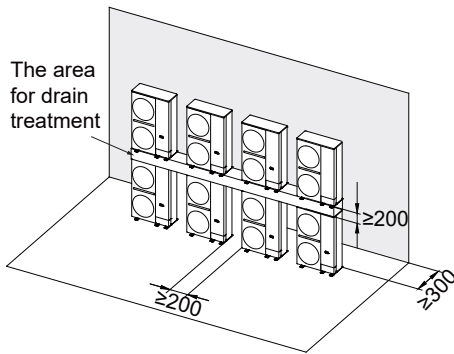

Fig. 5.12

- Only the air outlet side of the outdoor unit has obstacles:

Unit:mm

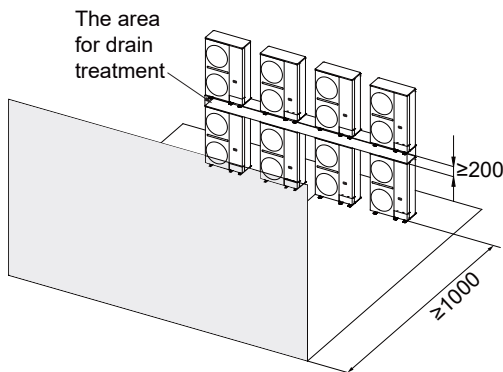

Fig. 5.13

When outdoor units are installed in rows on a rooftop

- When one outdoor unit is installed in each row:

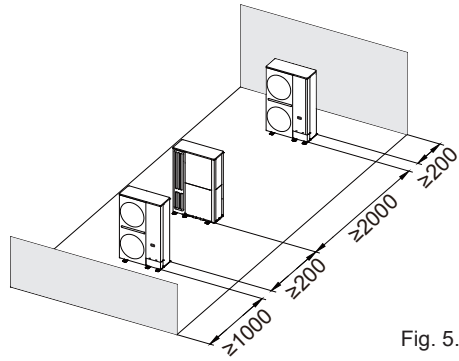

Fig. 5.14

- When two or more outdoor units are installed side by side in each row:

Unit:mm

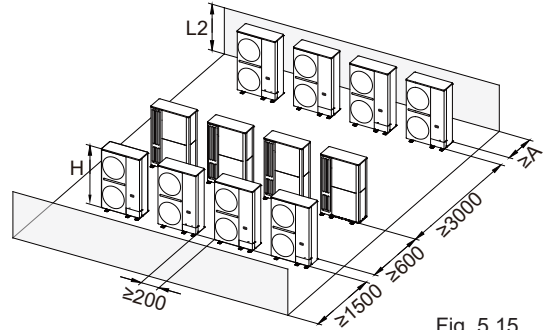

Fig. 5.15

Table 5.4

Condition	L2	A
L2 ≤ H	0 < L2 < 1/2H	300
	1/2H ≤ L2 ≤ H	450
L2 > H	Install air duct to exhaust the air out of the space.	

- The air outlet of outdoor units facing to the air inlet of the outdoor units in the front is forbidden, when outdoor units are installed in rows:

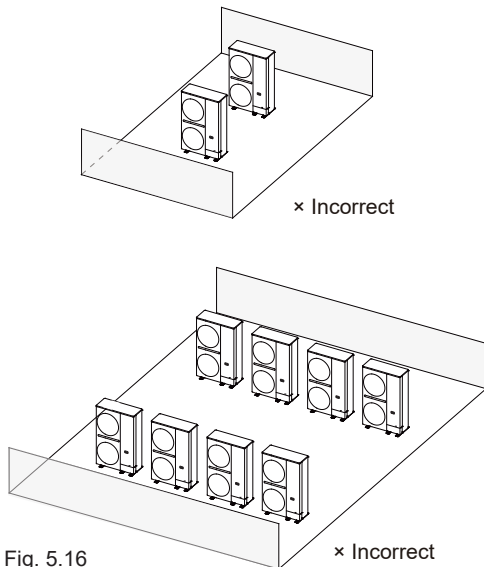

Fig. 5.16

Installation requirements of outdoor unit in space with shutters

- When the outdoor unit is installed in the space with shutters, the distance between the air outlet and the shutters must be $\leq 0.5\text{m}$; When the distance between the air outlet and the shutter cannot meet the requirements, the air duct must be installed.

Unit:mm

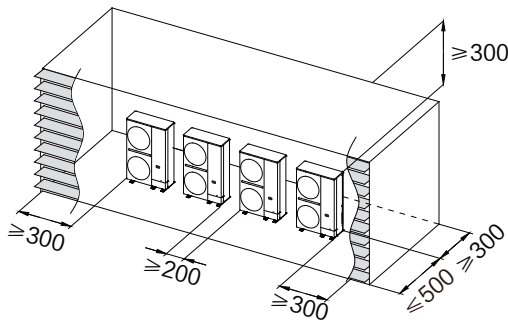
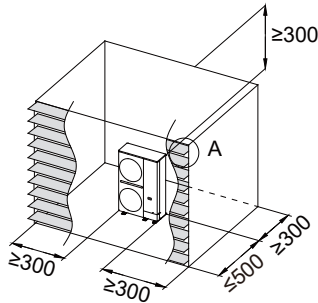
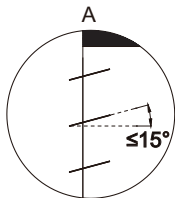

Fig. 5.17

- The shutter opening rate of the shutter is greater than 90%, and the shutter angle is less than 15° .



NOTE

- The installation space shown above is for refrigeration operation under the assumption that the outdoor temperature is 35°C . If the outdoor temperature exceeds 35°C or the heat load is large, and all outdoor units operate in excess of capacity, the space required on the air inlet side shall be increased.
- If the air duct needs to be added when the above installation space conditions are not met, please refer to "Installation of outdoor unit ducting" for the installation requirements and methods.

5.3.3 Vibration Reduction of outdoor unit

The ODU shall be firmly fixed, and a thick rubber plate or corrugated shock-absorbing rubber cushion with a thickness of more than 20mm and a width of more than 100mm shall be placed between the unit and the foundation. The shock-absorbing rubber cushion cannot only support the four corners of the unit, and the setting requirements are shown in the figure below.

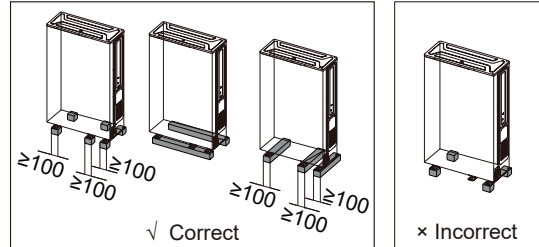

Fig. 5.18

5.4 Piping Installation

5.4.1 Things to note when connecting the refrigerant piping

Make sure the refrigerant piping is installed in accordance with the applicable law.

Make sure the piping and connections are not placed under pressure.

5.4.2 Connect refrigerant piping

CAUTION

- Clean and new pipes shall be used for refrigerant piping, water and foreign matters shall not enter the pipe during construction; If water and foreign matters enter, be sure to flush the pipeline with nitrogen.
- Be careful when the pipeline passes through the wall. Please cover both ends of the pipeline with adhesive tape or rubber plug to prevent foreign matters.
- The pipe connection shall follow the following principles: the shorter the connected pipe, the smaller the height difference between indoor and outdoor units, the less the pipe bending angle, and the larger the bending radius as much as possible.
- When laying according to the predetermined route, the pipe shall not be flattened. The bending radius of the bending part must be greater than 200mm. The connecting pipe cannot be stretched or bent frequently. One pipe cannot be bent at the same place for more than 3 times at most.

Before the refrigerant piping is connected, make sure the indoor units and outdoor units are installed properly. Connecting refrigerant piping include:

- Connect refrigerant piping to outdoor unit
- Connect refrigerant piping to indoor unit (refer to the installation manual of the indoor unit)
- Connecting branch joints .

⚠ CAUTION

- Remove the valve cover and make sure that the stop valve is fully closed.
- Connect a vacuum gauge to the needle valve port and make sure there is no residual pressure in the tube.
- Use pliers and other tools to completely cut off the small sealing tube.
- Remove the large sealing tube.

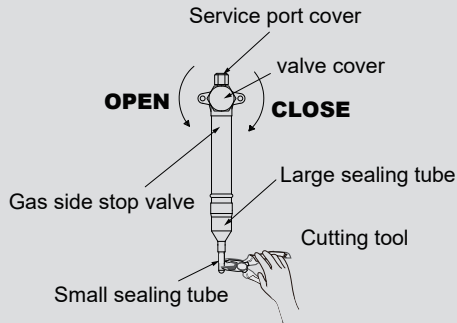

5.4.3 Outdoor refrigerant connecting pipe position

The outdoor refrigerant connecting pipe position is shown in the following figure.

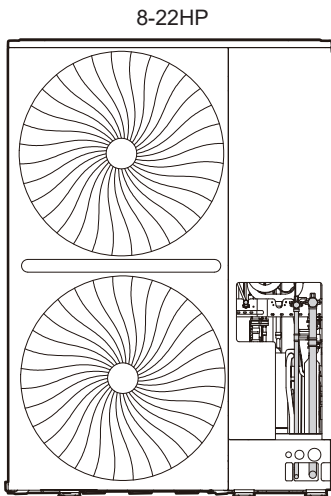

Fig. 5.19

5.4.4 Connecting refrigerant piping to outdoor unit

💡 NOTE

- Be sure that the field installed piping does not touch other pipes, the bottom panel or side panel.
- Be sure to protect the piping with suitable insulation for the bottom and side connection, to prevent it from coming into contact with the casing.

The fittings provided as accessories can be used to complete the connection from the stop valve to the field piping.

- Field piping can be connected in 4 directions. Before connecting, knock off the plate in the corresponding direction.

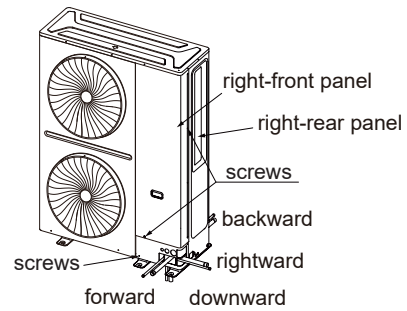

Fig. 5.20

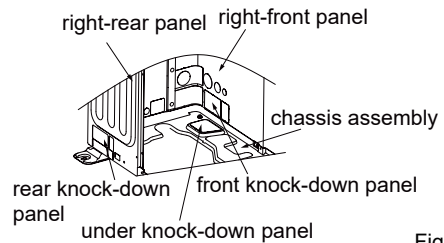

Fig. 5.21

- The connection method of the forward outlet pipe

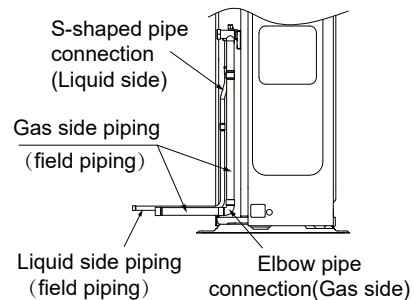
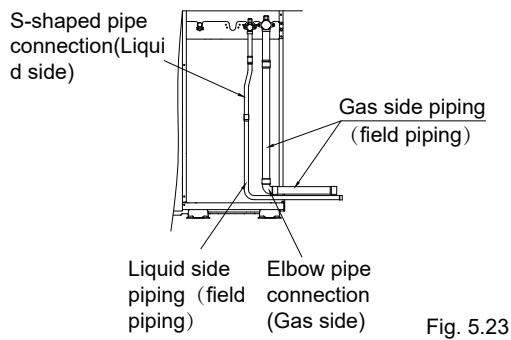
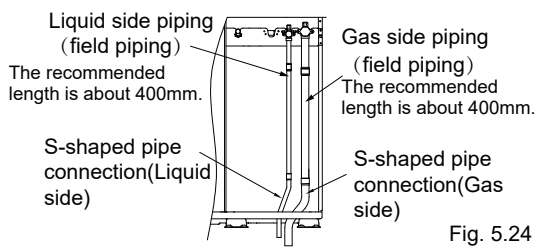

Fig. 5.22

- The connection method of the rightward outlet pipe.



- The connection method of the downward outlet pipe.



- The connection method of the backward outlet pipe.

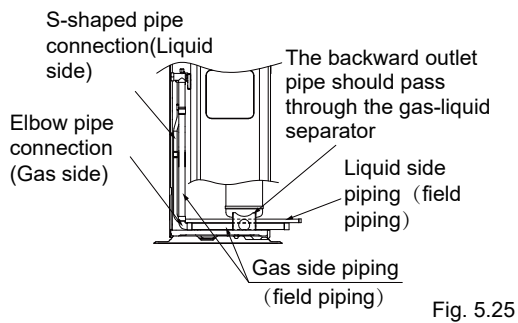

5.4.5 Connecting Branches

CAUTION

- The wrong installation will cause the unit to malfunction.

5.4.5.1 U-type branch joint

The branch joints should be as level as possible, and the angular error does not exceed 10°.

U type branch joint

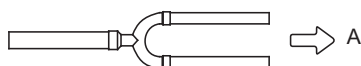

A-direction view

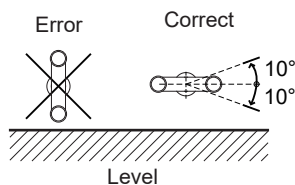

The branch joints come in different pipe diameters, which can be easily matched with different pipe diameters. When connecting pipes, select the pipe section with the appropriate pipe diameter, cut it in the middle with a pipe cutter and remove burrs, as shown in the figure below.

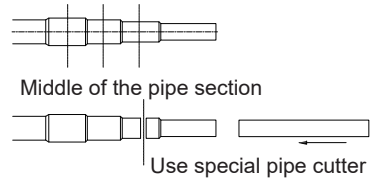

Fig. 5.27

The length of the straight pipe section between the continuous branch pipes shall be no less than 500mm. The straight pipe section behind the branch pipe end shall be no less than 500mm. The length of straight pipe between two right angle bends shall be no less than 500mm.

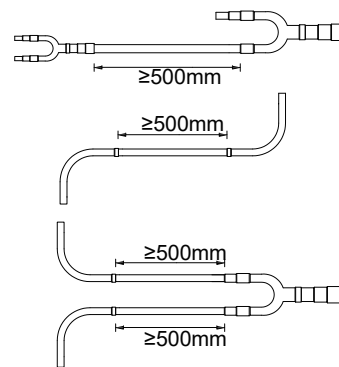

Fig. 5.28

5.4.5.2 Branch header

NOTE

- For installation of the branch header, refer to the installation manual delivered with the kit.
- Install the branch header horizontally.

- Don't install two branch headers serially

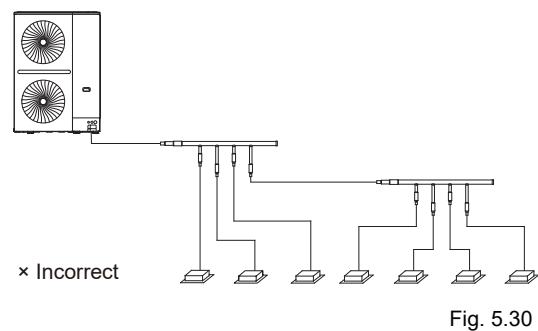
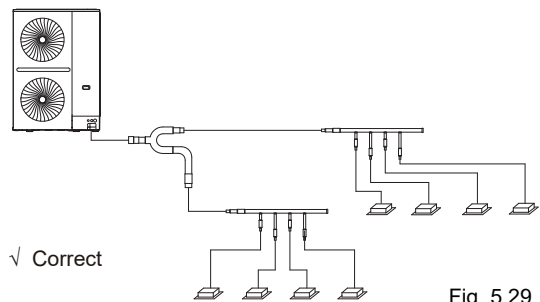

- Each branch can only connect to one indoor unit, but not another branch joint.

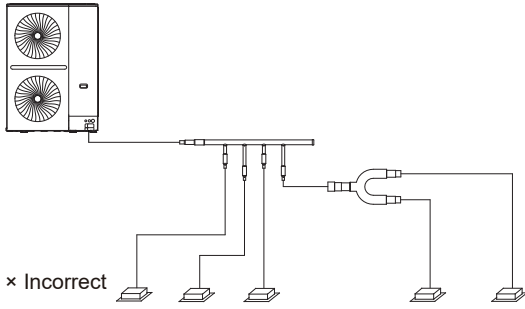

Fig. 5.31

- The straight horizontal piping distance between two adjacent branch joints should $\geq 0.5\text{m}$. The straight horizontal piping distance which indoor unit connecting behind the branch joints should $\geq 0.5\text{m}$.

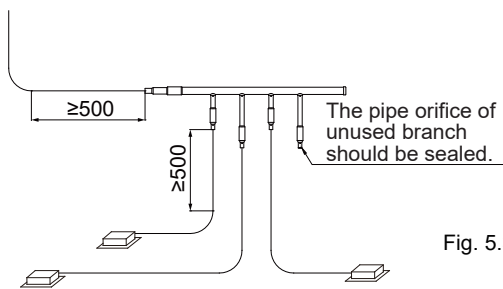

Fig. 5.32

5.4.6 Brazing

CAUTION

- During the test, do not exert a force greater than the maximum allowed pressure on the product (as shown on the nameplate).

- During brazing, use nitrogen as protection to prevent the formation of a large amount of oxide film in the pipes. This oxide film will have adverse effects on the valves and compressors in the cooling system, and may hamper normal operations.
- Use the pressure reducing valve to set the nitrogen pressure to 0.02~0.03 MPa (a pressure that can be felt by the skin).

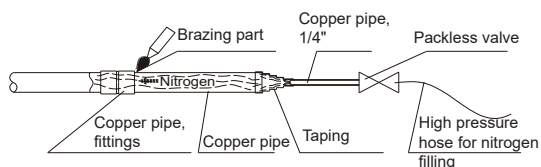

Fig. 5.33

- Do not use antioxidants when brazing the pipe joints.
- Use copper-phosphorus alloys (BCuP) when brazing copper and copper, and no flux is required. When brazing copper and other alloy, flux is required. Flux produces an extremely harmful effect on the refrigerant piping system. For example, using a chlorine-based flux is used may corrode the pipes, and when the flux contains fluorine, it will degrade the frozen oil.

5.4.7 About stop valves

Stop valves

- The following figure shows the names of all parts required for the installation of the stop valves.
- Stop valves are closed when unit is shipped from the factory.

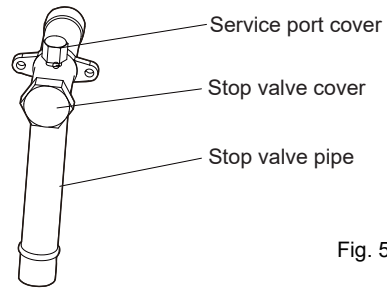

Fig. 5.34

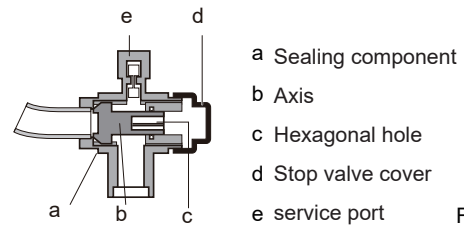

Fig. 5.35

Using of stop valve

1. Remove the stop valve cover.
2. Insert the hex wrench into the stop valve, and rotate the stop valve counter-clockwise.
3. Stop turning when the stop valve cannot be rotated further.

Result: Valve is now open.

The fastening torque of the stop value is shown in table 5-5. Insufficient torque may cause the refrigerant to leak.

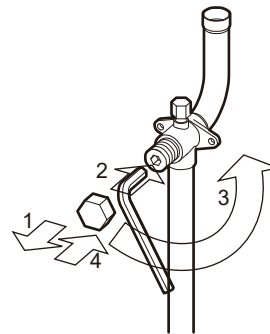

Fig. 5.36

Closing the stop valve

1. Remove the stop valve cover.
2. Insert the hex wrench into the stop valve, and rotate the stop valve clockwise.
3. Stop turning when the stop valve cannot be rotated further.

Result: Valve is now closed.

Direction to close:

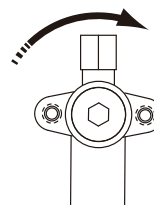

Fig. 5.37

Fastening torque

Table 5.5

Stop valve size (mm)	Tightening torque / N.m (turn clockwise to close)	
	Axis	
	Valve body	
Φ12.7	9~30	
Φ15.9	12~30	
Φ19.1		
Φ22.2	16~30	
Φ25.4	24~30	
Φ28.6		
Φ31.8	25~35	
Φ35.0		

5.5 Flushing Pipes

To remove dust, other particles and moisture, which could cause compressor malfunction if not flushed out before the system is run, the refrigerant piping should be flushed using nitrogen. Pipe flushing should be performed once the piping connections have been completed with the exception of the final connections to the indoor units. That is, flushing should be performed once the outdoor units have been connected but before the indoor units are connected.

CAUTION

Only use nitrogen for flushing. Using carbon dioxide risks leaving condensation in the piping. Oxygen, air, refrigerant, flammable gases and toxic gases must not be used for flushing. Use of such gases may result in fire or explosion.

The liquid and gas sides must be flushed simultaneously.

The flushing procedure is as follows:

- Cover the inlets and outlets of the indoor units to prevent dirt getting blown in during pipe flushing. (Pipe flushing should be carried out before connecting the indoor units to the piping system.)
- Attach a pressure reducing valve to a nitrogen cylinder.
- Connect the pressure reducing valve outlet to the inlet on the liquid (or gas) side of the outdoor unit.
- Use blind plugs to block all liquid (gas) side openings, except for the opening at the indoor unit which is furthest from the outdoor units ("Indoor unit A" in Fig.5.38).
- Start to open the nitrogen cylinder valve and gradually increase the pressure to 0.5Mpa.
- Allow time for nitrogen to flow as far as the opening at indoor unit A.
- Flush the first opening:
 - Using suitable material, such as a bag or cloth, press firmly against the opening at indoor unit A.
 - When the pressure becomes too high to block with your hand, suddenly remove your hand allowing gas to rush out.
 - Repeatedly flush in this manner until no further dirt or moisture is emitted from the piping. Use a clean cloth to check for dirt or moisture being emitted. Seal the opening once it has been flushed.

8.Flush the other openings in the same manner, working in sequence from indoor unit A towards the outdoor units. Refer to Fig.5.39

9.Once flushing is complete, seal all openings to prevent dust and moisture from entering.

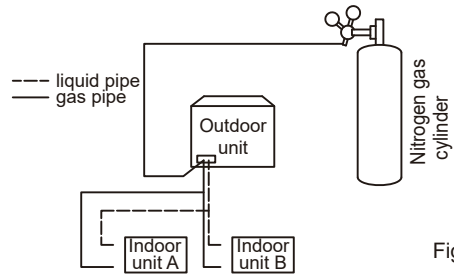

Fig.5.38

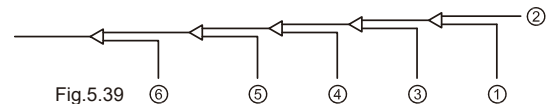

Fig.5.39

5.6 Gas Tightness Test

To prevent faults caused by refrigerant leakage, a gas tightness test should be performed before system commissioning.

NOTE

- Only dry nitrogen should be used for gas tightness testing. Oxygen, air, flammable gases and toxic gases must not be used for gas tightness testing. Use of such gases may result in fire or explosion.
- Make sure that all the outdoor unit stop valves are firmly closed.
- Make sure all piping connections are complete before the tightness test begins.

The gas tightness test procedure is as follows:

- Charge the indoor piping with nitrogen at 0.3Mpa through the needle valves on the liquid and gas stop valves and leave for at least 3 minutes (do not open the liquid or gas stop valves). Observe the pressure gauge to check for large leakages. If there is a large leakage, the pressure gauge will drop quickly.
- If there are no large leakages, charge the piping with nitrogen at 1.5Mpa and leave for at least 3 minutes. Observe the pressure gauge to check for small leakages. If there is a small leakage, the pressure gauge will drop distinctly.
- If there are no small leakages, charge the piping with nitrogen at 4.2 MPa and leave for at least 24 hours to check for micro leakages. Micro leakages are difficult to detect. To check for micro leakages, allow for any change in ambient temperature over the test period by adjusting the reference pressure by 0.01Mpa per 1°C of temperature difference. Adjusted reference pressure = Pressure at pressurization + (temperature at observation – temperature at pressurization) x 0.01Mpa. Compare the observed pressure with the adjusted reference pressure. If they are the same, the piping has passed the gas tightness test. If the observed pressure is lower than the adjusted reference pressure, the piping has a micro leakage.

4.If the leakage is detected, refer to following part “Leak detection”. Once the leak has been found and fixed, the gas tightness test should be repeated.

5.If not continuing straight to vacuum drying once the gas tightness test is complete, reduce the system pressure to 0.5-0.8MPa and leave the system pressurized until ready to carry out the vacuum drying procedure.

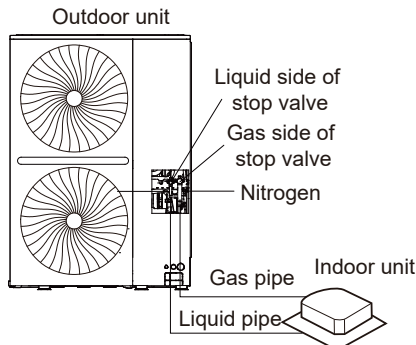

Fig.5.40

Leak detection

The general methods for identifying the source of a leak are as follows:

1. Audio detection: relatively large leaks are audible.
2. Touch detection: place your hand at joints to feel for escaping gas.
3. Soapy water detection: small leaks can be detected by the formation of bubbles when soapy water is applied to a joint.

5.7 Vacuum Drying

Vacuum drying should be performed in order to remove moisture and non-condensable gases from the system. Removing moisture prevents ice formation and oxidization of copper piping or other internal components. The presence of ice particles in the system would cause abnormal operation, whilst particles of oxidized copper can cause compressor damage. The presence of non-condensable gases in the system would lead to pressure fluctuations and poor heat exchange performance.

Vacuum drying also provides additional leak detection (in addition to the gas tightness test).

⚠ CAUTION

- Before performing vacuum drying, make sure that all the outdoor unit stop valves are firmly closed.
- Once the vacuum drying is complete and the vacuum pump is stopped, the low pressure in the piping could suck vacuum pump lubricant into the air conditioning system. The same could happen if the vacuum pump stops unexpectedly during the vacuum drying procedure. Mixing of pump lubricant with compressor oil could cause compressor malfunction. Therefore a check valve should be used to prevent vacuum pump lubricant seeping into the piping system.

During vacuum drying, a vacuum pump is used to lower the pressure in the piping to the extent that any moisture present evaporates. At 5mm Hg (755mm Hg below typical atmospheric pressure) the boiling point of water is 0°C. Therefore a vacuum pump capable of maintaining a pressure of -756 mm Hg or lower should be used. Using a vacuum pump with a discharge in excess of 4 L/s and a precision level of 0.02mm Hg is recommended. The vacuum drying procedure is as follows:

1. Connect the vacuum pump through a manifold with a pressure gauge to the service port of all stop valves.
2. Start the vacuum pump and then open the manifold valves to start vacuuming the system.
3. Continue vacuum drying for at least 2 hours and until a pressure difference of -0.1 MPa or more has been achieved. Once the pressure difference of at least -0.1 MPa has been achieved, continue vacuum drying for 2 hours. Close the manifold valves and then stop the vacuum pump. After 1 hour, check the pressure gauge. If the pressure in the piping has not increased, the procedure is finished. If the pressure has increased, repeat the steps 1 to 3 until all moisture has been removed.
4. After vacuum drying, keep the manifold connected to the master unit stop valves, in preparation for refrigerant charging.

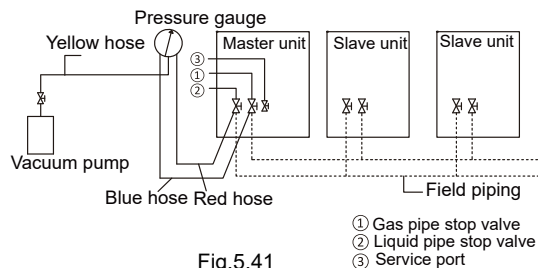

Fig.5.41

5.8 Piping Insulation

After the leak test and the vacuum drying are completed, the pipe must be insulated. Considerations:

- Make sure the refrigerant piping and branch joints are completely insulated.
- Make sure the liquid and gas pipes (for all units) are insulated.
- Use heat-resistant polyethylene foam for the liquid pipes (able to withstand temperature of 70°C), and polyethylene foam for the gas pipes (able to withstand temperature of 120°C).
- Reinforce the insulation layer of the refrigerant piping based on the installation environment.

5.8.1 Selection of insulation material thickness

Condensed water may form on the surface of the insulation layer.

Table 5.6

Piping size	Humidity<80%RH Thickness	Humidity≥80%RH Thickness
Φ6.35~38.1 mm	≥ 15 mm	≥ 20 mm
Φ41.3~54.0 mm	≥ 20 mm	≥ 25 mm

5.8.2 Pipe wrapping

To avoid condensation and water leakage, the connecting pipe must be wrapped with tape to ensure isolation from the air.

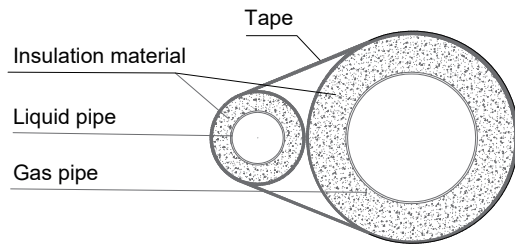

Fig.5.42

When wrapping insulation tape, each circle should press half of the previous circle of tape. Do not wrap the tape too tightly to avoid reducing the thermal insulation effect.

After completing the pipe insulation work, seal the holes in the wall with sealing material.

5.8.3 Protective measures of the pipeline

The refrigerant pipe will swing, expand or shrink during operations. If the pipe is not fixed, the load will be concentrated in a certain part, which may cause the deformation or rupture of the refrigerant pipe.

The suspended connecting pipes shall be well supported, and the distance between supports shall not exceed 1m.

The outdoor pipes shall be protected against accidental damage. If the length of the pipe exceeds 1m, a gusset plate must be added for protection.

5.9 Refrigerant Charging

⚠ WARNING

- Use only R410A as the refrigerant. Other substances may cause explosions and accidents.
- R410A contains fluorinated greenhouse gases, and the GWP value is 2088. Do not discharge the gas into the atmosphere.
- When charging the refrigerant, make sure you wear protective gloves and safety glasses. Be careful when you open the refrigerant piping.

💡 NOTE

- If the power supply of some units is off, the charging program cannot be completed normally.
- If this is a multi-unit outdoor system, the power supply for all outdoor units should be turned on.
- Make sure the power supply is turned on 12 hours before operations so that the crankcase heater is properly energized. This is also to protect the compressor.
- Make sure all connected indoor units have been identified.
- Charge the refrigerant only after vacuum drying.
- Volume of refrigerant charged must not exceed the designed amount.

Calculating additional refrigerant charge

The additional refrigerant charge required depends on the lengths and diameters of the outdoor and indoor liquid pipes. Table below shows the additional refrigerant charge required per meter of equivalent pipe length for different diameters of pipe. The total additional refrigerant charge is obtained by summing the additional charge requirements for each of the outdoor and indoor liquid pipes, as in the following formula, where T1 to T8 represent the equivalent lengths of the pipes of different diameters. Assume 0.5m for the equivalent pipe length of each branch joint.

Table 5.7

Liquid piping Diameter (mm OD)	Additional refrigerant charge per meter of equivalent length of liquid piping (kg)
Φ6.35	0.022
Φ9.52	0.057
Φ12.7	0.110
Φ15.9	0.170
Φ19.1	0.260
Φ22.2	0.360
Φ25.4	0.520
Φ28.6	0.680

$$\text{Additional refrigerant charge } R \text{ (kg)} = (T1@Φ6.35) \times 0.022 + (T2@Φ9.52) \times 0.057 + (T3@Φ12.7) \times 0.110 + (T4@Φ15.9) \times 0.170 + (T5@Φ19.1) \times 0.260 + (T6@Φ22.2) \times 0.360 + (T7@Φ25.4) \times 0.520 + (T8@Φ28.6) \times 0.680.$$

NOTE

- Strictly follow the preconditions shown in the above refrigerant charging amount calculation method, and determine that the additional amount shall not exceed the maximum refrigerant additional amount shown in the table below. If the calculated value of additional refrigerant exceeds the limits shown in the table below, the total length of the pipeline construction scheme shall be shortened and the refrigerant charging amount shall be recalculated to meet the requirements shown in the table below.
- The maximum refrigerant addition shown in the table below is based on the recommended combination.

Table 5.8

HP	maximum refrigerant addition (kg)	HP	maximum refrigerant addition (kg)
8	19	50	62.5
10	21	52	62.5
12	23	54	68.5
14	23	56	75
16	29	58	75
18	29	60	75
20	30	62	75
22	30	64	75
24	38.5	66	75
26	44	68	76
28	44	70	76
30	48	72	76
32	50	74	77
34	50	76	77
36	54	78	77
38	54	80	77
40	55	82	93
42	55	84	93
44	55	86	93
46	64.5	88	93
48	65		

The procedure for adding refrigerant is as follows:

1. Calculate additional refrigerant charge R (kg).
2. Place a tank of R410A refrigerant on a weighing scale.
Turn the tank upside down to ensure refrigerant is charged in a liquid state. (R410A is a blend of two different chemicals compounds. Charging gaseous R410A into the system could mean that the refrigerant charged is not of the correct composition).
3. After vacuum drying, the blue and red pressure gauge hoses should still be connected to the pressure gauge and to the master unit stop valves.
4. Connect the yellow hose from the pressure gauge to the R410A refrigerant tank.
5. Open the valve where the yellow hose meets the pressure gauge, and open the refrigerant tank slightly to let the refrigerant eliminate the air. Caution: open the tank slowly to avoid freezing your hand.
6. Set the weighing scale to zero.
7. Open the three valves on the pressure gauge to begin charging refrigerant.
8. When the amount charged reaches R (kg), close the three valves. If the amount charged has not reached R (kg) but no additional refrigerant can be charged, close the three valves on the pressure gauge, run the outdoor units in cooling mode, and then open the yellow and blue valves. Continue charging until the full R (kg) of refrigerant has been charged, then close the yellow and blue valves. Note: Before running the system, be sure to complete all the pre-commissioning checks and be sure to open all stop valves as running the system with the stop valves closed would damage the compressor.

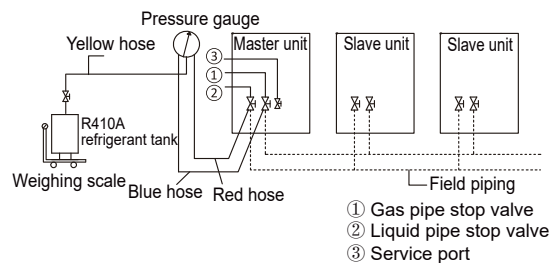

Fig 5.42

5.10 Electrical Wiring

5.10.1 Electrical wiring precautions

WARNING

- Take note of the risk of electric shocks during installation.
- All the electric wires and components must be installed by an installation personnel with the proper electrician certification, and the installation process must comply with the applicable regulations.
- Use only wires with copper cores for the connections.
- A main switch or safety device that can disconnect all polarities must be installed, and the switching device can be completely disconnected when the corresponding excessive voltage situation arises.
- Wiring must be carried out in strict accordance with what is stated in the product nameplate.

⚠ WARNING

- Do not squeeze or pull the unit connection, and make sure the wiring is not in contact with the sharp edges of the sheet metal.
- Make sure the earthing connection is safe and reliable. Do not connect the earth wire to public pipes, telephone earth wires, surge absorbers and other places that are not designed for earthing. Improper earthing may cause electric shock.
- Make sure the fuses and circuit breakers installed meet the corresponding specifications.
- Make sure an electric leakage protection device is installed to prevent electric shocks or fires.
- The model specifications and characteristics (anti high-frequency noise characteristics) of the electric leakage protection device are compatible with the unit to prevent frequent tripping.
- Before power on, make sure the connections between the power cord and terminals of the components are secure, and the metallic cover of the electric control box is closed tightly.

⚠ CAUTION

- If the power supply lacks N phase or there is an error in the N phase, the device will malfunction.
- Some power equipment may have reverse-phase phase or intermittent phase (such as a generator). For this type of power sources, a reverse-phase protection circuit should be installed locally in the unit, as operating in the inverted phase may damage the unit.
- Do not share the same power supply line with other devices.
- The power cord may produce electromagnetic interference so you should maintain a certain distance from equipment that may be susceptible to such interference.
- Separate power supply for the indoor and outdoor units.
- For systems with multiple units, make sure a different address is set for each outdoor unit.

5.10.2 Layout

Wiring layout comprises of the power cords and communication wiring between the indoor and outdoor units. These include the earth wires, and the shielded layer of the earth wires of the indoor units in the communication wiring. See below the wiring layout of outdoor unit.

⚠ WARNING

- If you want to remove the electric control box as a whole, you need to release the refrigerant in the system first, weld and disconnect the connecting pipe of the refrigerant radiator at the right rear of the electric control box, and remove all cables connected between the electric control box and the air conditioner at the same time.

- Upper electric control box-front

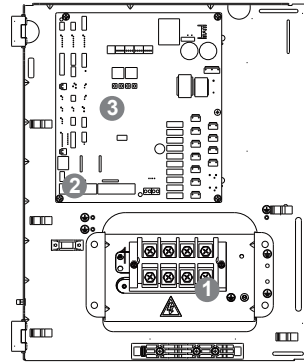

Fig 5.43

- Upper electric control box-back

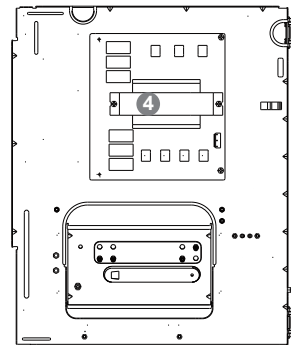

Fig 5.44

- Lower electric control box-front

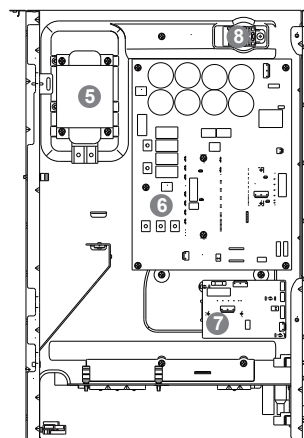

Fig 5.45

① Power supply cable terminal	⑤ Reactor
② Communication wiring terminal	⑥ Inverter module board 1
③ Main PCB	⑦ Inverter module board 2
④ Filter board	⑧ Humidity sensor

5.10.3 Wiring layout

The wiring layout comprises the power cords and communication wiring between the indoor and outdoor units. These include the earth wires, and the shielded layer of the earth wires of the communication wiring. See below the wiring layout of outdoor unit.

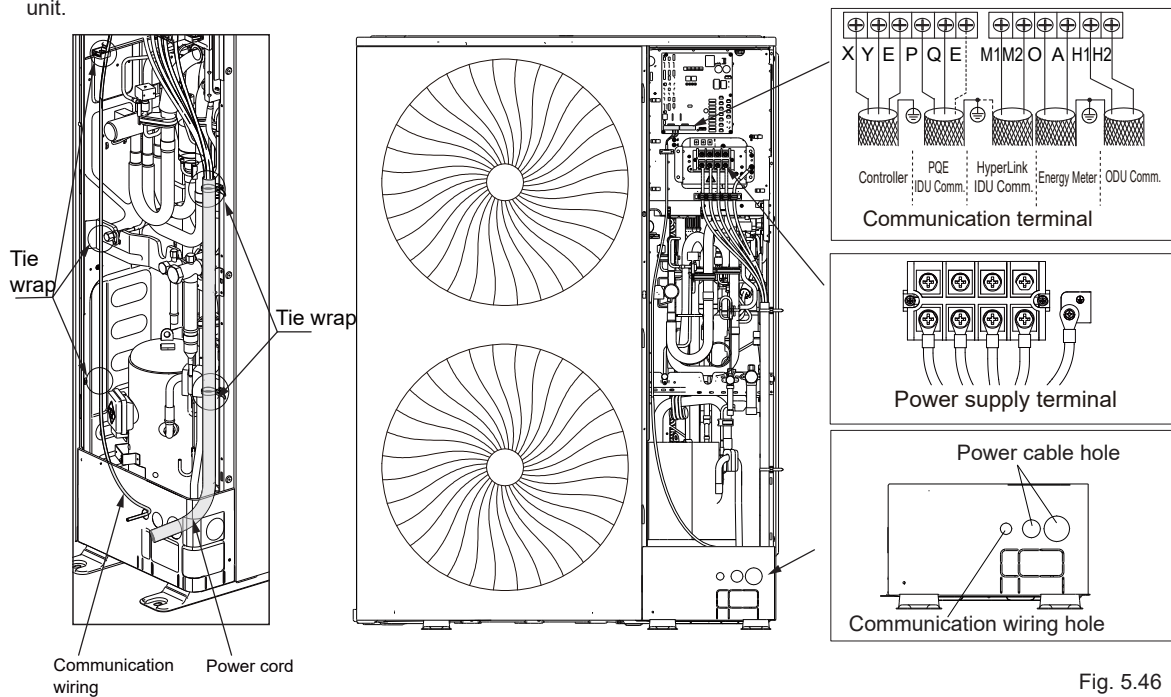

Fig. 5.46

⚠ CAUTION

- Power cords and communication wiring must be laid out separately, they cannot be placed in the same conduit. Use a power supply conduit to isolate if the current of the power supply is less than 10 A. If the current is greater than 10 A but less than 50 A, the spacing must exceed 50 mm at all times. Otherwise, it may lead to electromagnetic interference.
- Arrange the refrigerant piping, power cords and communication wiring in parallel, but do not tie the communication wiring together with the refrigerant piping or power cords.
- Power cords and communication wiring should not come in contact with the internal piping so as to prevent the high temperature piping from damaging the wires.

5.10.3 Connecting the power cord

⚠ CAUTION

- Do not connect the power supply to the communication terminal block. Otherwise, the whole system may fail.
- Turn off the power supply first.
- Connect the earth wires, earth wires must use yellow-green wire.
- Earth wires are recommended to perform curling.
- Do not tighten the terminal with an appropriate screwdriver. Screwdrivers that are too small may damage the terminal head, and cannot tighten it.

⚠ CAUTION

- The power supply cable diameter must comply with the specified specification.
- The power supply cable must be clamped to prevent external force being applied to the terminal.

1. Use round-type terminals of the correct specifications to connect the power cable.

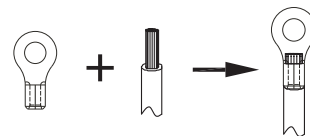

Fig 5.47

⚠ WARNING

- Use rubber cable grommets to knockout holes to avoid power supply cable and communication wiring being worn.

2. Connect the power cord according to the sign "L1,L2,L3,N" and connect the earth wire according to the sign "⊕".

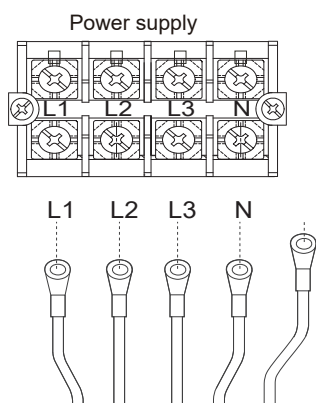

Fig 5.48

⚠ WARNING

- Terminals must be used for connection. Use round-type terminals of the correct specifications to connect the power cables. Do not directly connect the cable ends. Use the correct terminal, or it may cause heating and fire.

3. Fasten and fix the cables with wire clamp to avoid stress on the terminals.

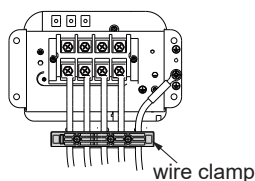

Fig 5.49

4. Press the plastic board of the power line terminal back and confirm that the power phase sequence is correct again.

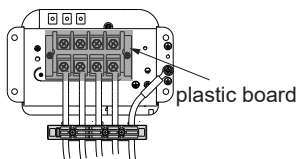

Fig 5.50

⚠ WARNING

- Select a proper torque according to the screw size.
- Too small torque may cause poor contact, resulting in heating of the terminals and fire. Too large torque may damage the screws and power supply terminals.

The size of the screws and recommended torque are as follows:

Table 5.9

Screw size	Standard value (kgf.cm)/(Nm)
M4	12.2/1.2
M8	61.2/6.0

⚠ CAUTION

- During installation, the earth wire shall be longer than the current carrying conductor to ensure that when the fixing device is loose, the earth wire is still not stressed and can be reliably earthed.
- When inserting the strong-current cables and communication wiring into the wiring holes, they must be equipped with wiring across rings. Otherwise, they may be worn out by the sheet metal and cause electric leakage or short circuit.

Outdoor unit wiring diagram

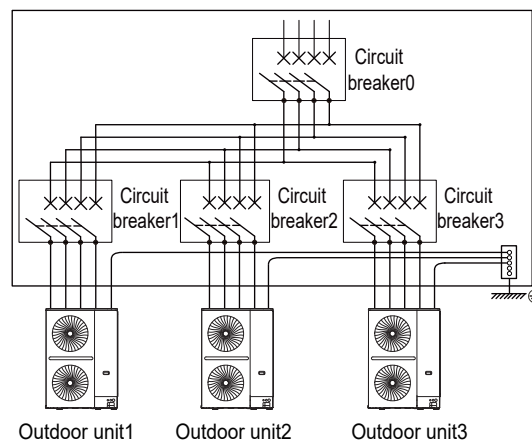

Fig 5.51

⚠ WARNING

- Do not connect the earth wire of the lightning rod to the unit shell. The earth wires of the lightning rod and the power cable must be configured separately.
- Each unit shall be equipped with a circuit breaker for short circuits and abnormal overload protection. In addition, the indoor and ODUs shall be equipped with a main circuit breaker respectively to connect or disconnect the main power supply of the indoor and ODUs.

5.10.4 Connecting the communication wiring

⚠ WARNING

- Do not connect the communication wiring when the power is on.
- Connect the shielding nets at both ends of the shielded wire to the sheet metal “⊕” of the electronic control box.
- Do not connect the power cable to the terminal of communication wiring, otherwise, the motherboard will be damaged.
- Do not connect a system with both HyperLink (M1 M2) communication wiring and PQ communication wiring.
- It is forbidden to reverse the connection of the two communication ports (to up IDU) and (to down IDU) of the repeater.

⚠ CAUTION

- On-site wiring must comply with the relevant regulations of the local Country/region and must be completed by professionals.
 - The communication wiring of the indoor and ODU's can only be led out and connected from the master ODU.
 - In combined system the communication wiring between the ODU's must be connected in series.
- When a single communication wiring is not long enough, the joint must be crimped or soldered, and the copper wire at the joint shall not be exposed.

Before connecting the communication wiring, please select the appropriate communication mode according to the type of indoor unit and refer to the following table.

Table 5.10 Communication mode

IDU and ODU type	Communication protocol	Optional communication mode between IDU and ODU
All IDUs and ODU's are V8 series	V8 communication protocol	HyperLink (M1 M2) communication
		RS-485 (P Q) communication
At least one IDU or ODU is not V8 series	Non-V8 communication protocol	RS-485 (P Q E) communication

Table 5.11 Communication wiring material

Communication mode	Type of wire	Number of cores and wire diameter (mm ²)	Total length of communication wiring (m)
RS-485 (P Q E) communication	PVC-sheathed copper-core flexible shielded cable	3x0.75	L≤1200
RS-485 (P Q) communication	PVC-sheathed copper-core flexible shielded twisted pair	2x0.75	L≤1200
HyperLink (M1 M2) communication (The IDUs in a system can be powered separately)	PVC-sheathed flexible cable	2x1.5	L≤600 (2 repeaters are required)
HyperLink (M1 M2) communication (All IDUs in a system must be powered through a unified power supply)	PVC-sheathed flexible cable	2x0.75	L≤2000

- HyperLink (M1 M2) communication wiring configuration – IDUs unified power supply
 $L1+La+Ln \leq 2000m$. Communication wiring $2 \times 0.75mm^2$

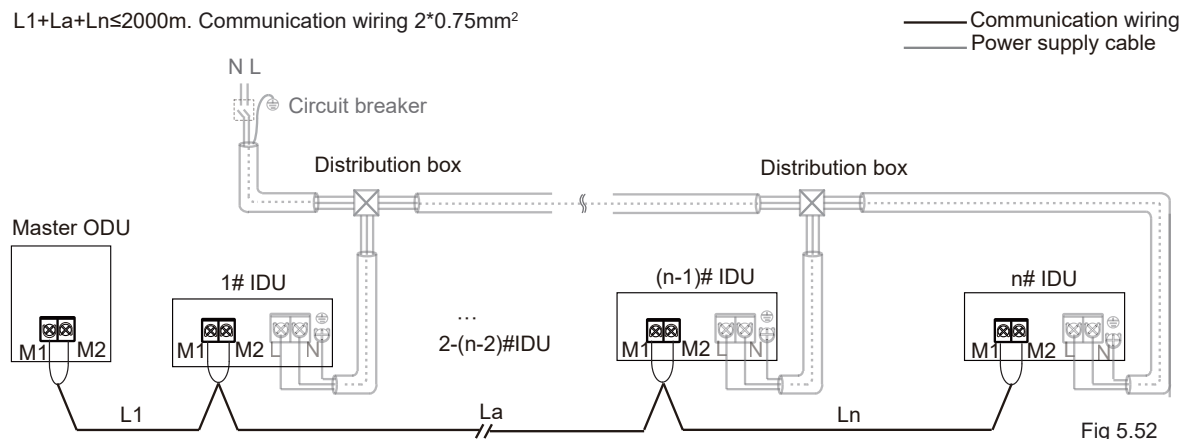

Fig 5.52

⚠ CAUTION

- Keep the power on/off for all IDUs.
- Do not connect the HyperLink (M1 M2) communication wiring to the PQ or D1D2 communication wiring.
- If the HyperLink (M1 M2) communication is available is required in the system, need to enable the function on the master ODU. For details, refer to section 7.5.

- HyperLink (M1 M2) communication wiring configuration – IDUs separate power supplied
 $L1+La+Lx \leq 200\text{m}$, $L11+Lb+Ly \leq 200\text{m}$, $L21+Lc+L30 \leq 200\text{mm}$. Communication wiring $2 \times 1.5\text{mm}^2$

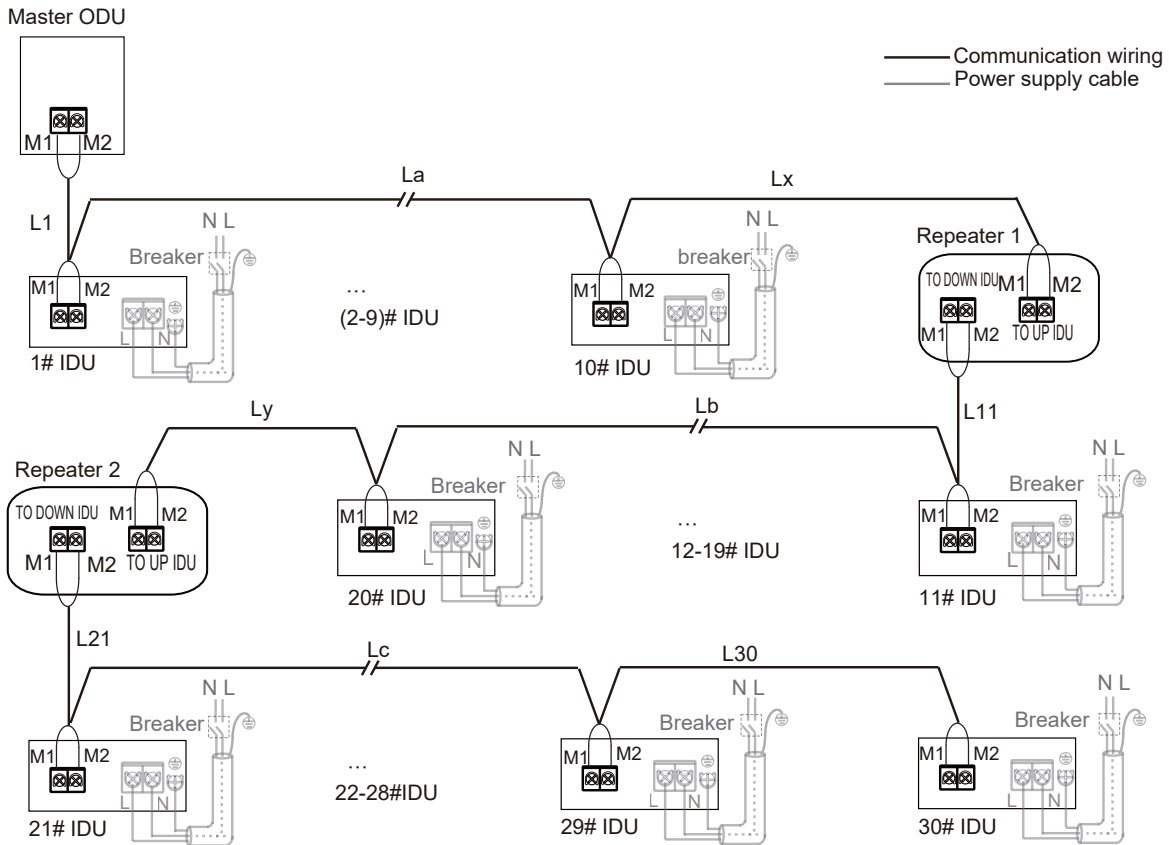

Fig 5.53

💡 NOTE

- If the total length is less than or equal to 200m and the total number of indoor units is less than or equals to 10 sets, the electronic expansion valve in indoor unit can be powered and controlled by the master outdoor unit.
- If the total length is longer than 200m or the total number of indoor units is more than 10 sets, a repeater is required to increase the bus voltage.
- The limit of one repeater is 200m cable length or maximum 10 indoor units.
- A maximum of two repeaters can be installed in the same refrigerant system.
- HyperLink communication can control the electronic expansion valve in indoor unit indenpently, this function requires the maximum number of indoor units in the same refrigerant system must be less than or equal to 30 sets.
- The repeaters and the outdoor units must connect to an unified power supply system, or the repeater uses an uninteruptible power supply.
- Refer to the Installation and Operation Manual of repeater for detail.
- For one repeater application, communication wiring among the master outdoor unit, indoor units and repeater must use the CN3 port in repater, the communication wiring among repeater and the rest indoor units must use the CN2 port in repeater.
- For two repeaters application, the communication wiring among the master outdoor unit, indoor units and repeater 1 must use the CN3 port in repater1, the communication wiring among repeater 1, indoor units and repeater 2 must use the CN2 port in repeater 1 and CN3 port in repeater 2.
- The electronic expansion valve in indoor unit can be powered and controlled by the master outdoor unit If a separate power supply applied for indoor units, refer to section 7.5 for detail.

- RS-485 (P Q) communication wiring configuration
 $L1+La+Ln \leq 1200m$. Communication wiring $2 \times 0.75mm^2$

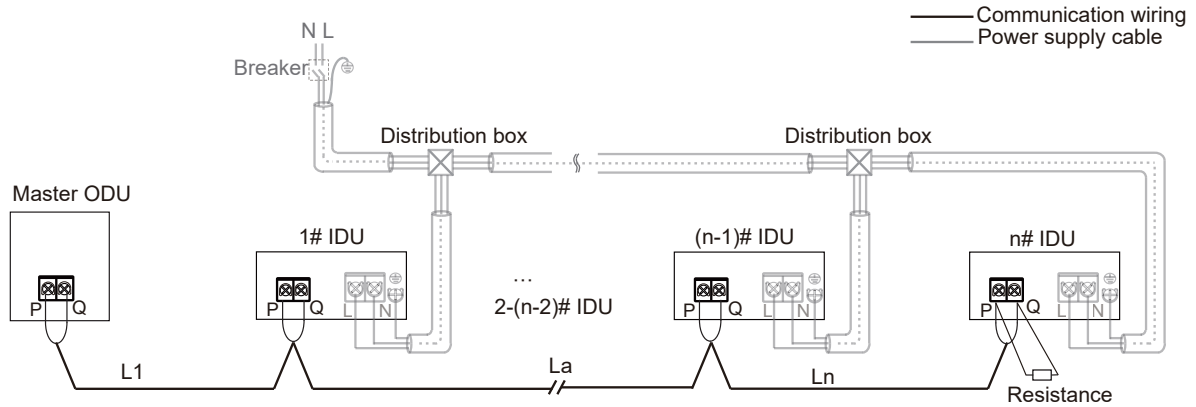

Fig 5.54

- RS-485 (P Q E) communication wiring configuration
 $L1+La+Ln \leq 1200m$. Communication wiring $3 \times 0.75mm^2$

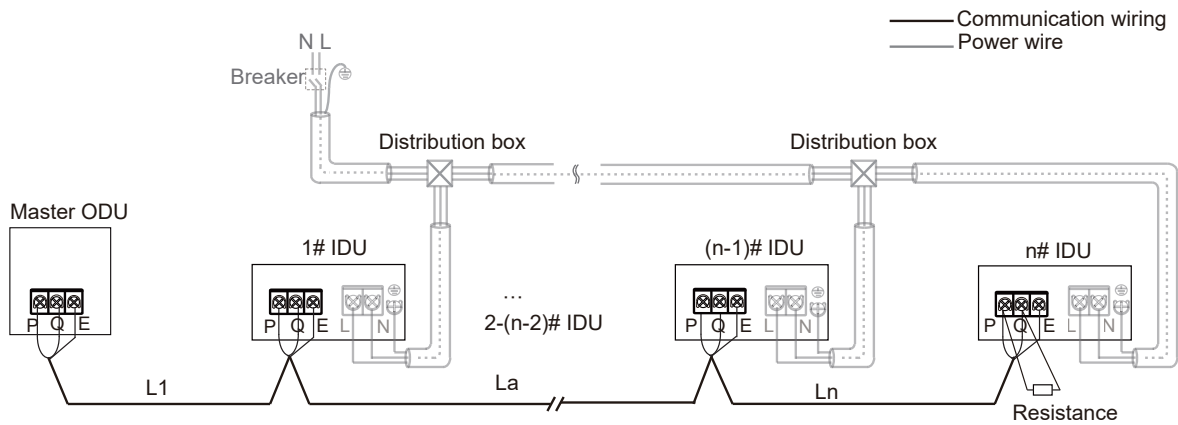

Fig 5.55

CAUTION

- After the last indoor unit, the communication wiring should not route back to the outdoor unit as this will form a closed loop.
- In the last indoor unit, connect a resistance of 120 ohms between the P and Q terminals.
- Do not bind the communication wiring, refrigerant piping and power cable together.
- When the power cable and communication wiring are laid in parallel, the distance between the two lines must be 5cm or more to prevent signal source interference.
- All IDUs in a system must be powered through a unified power supply so that they can be powered on or off at the same time.
- All communication wiring of the IDUs and ODUs must be connected in series, use the shielded wire, and the shield layer must be earthed.

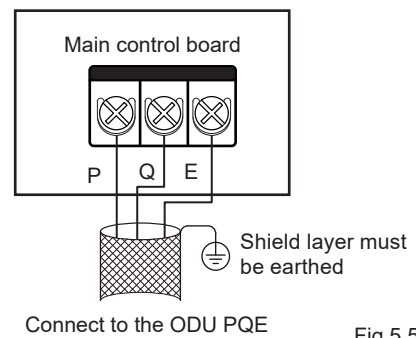

Fig 5.56

- XYE, H1H2 communication wiring

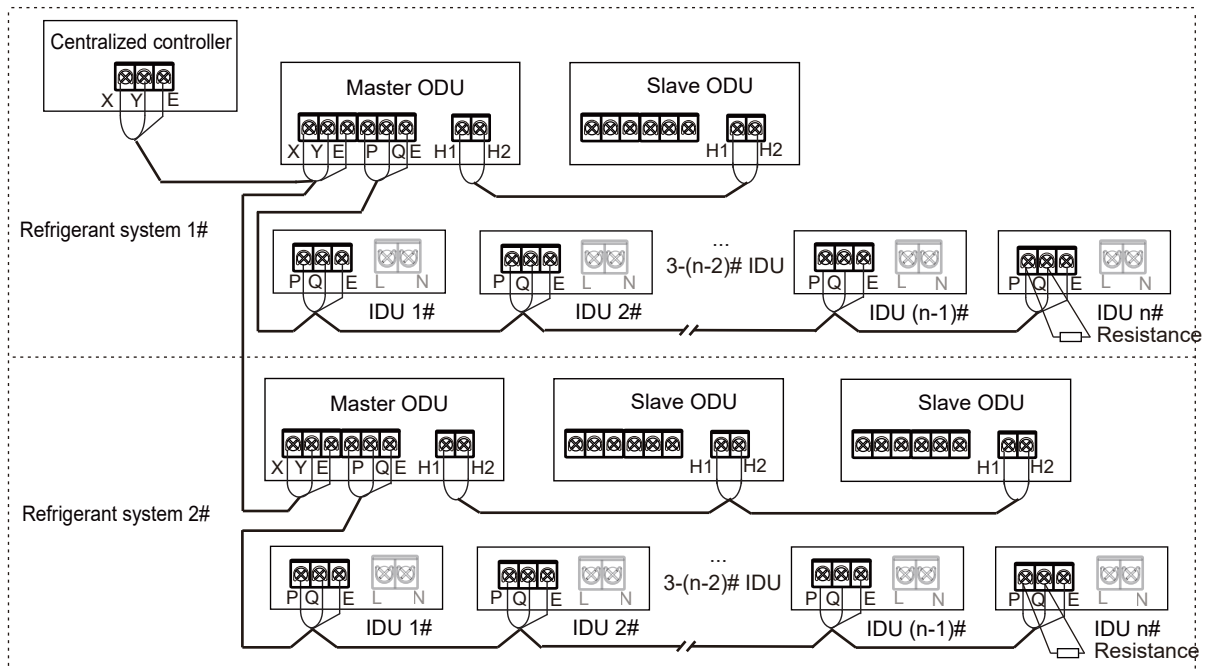

Fig 5.57

⚠ CAUTION

- The H1H2 communication wiring of the outdoor unit should be connected in a chain starting from the master unit to the last slave unit. The XYE communication wiring of the outdoor unit should be connected from the master unit.
- The cross-sectional area of each core of the communication wiring is not less than 0.75 mm², and the length must not exceed 1200m.
- Connect the shielding nets at both ends of the shielded wire to the sheet metal “⊕” of the electronic control box.

6 CONFIGURATION

6.1 Overview

This chapter describes how the system configuration can be implemented once the installation is complete, and other relevant information.

It contains the following information:

- Implement field settings
- Using the Check function

i INFORMATION

The installation personnel should read this chapter.

6.2 Digital Displays And Buttons

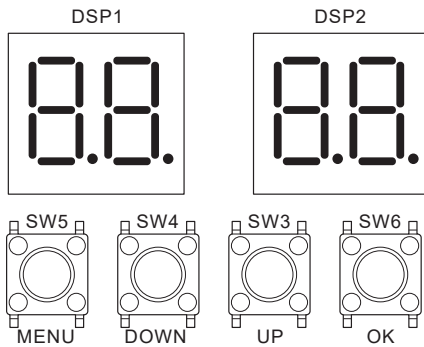

Fig 6.1

6.2.1 Digital display output

Table 6.1

Outdoor unit state	Parameters displayed on DSP1	Parameters displayed on DSP2
Standby	Unit's address	The number of online indoor unit.
Normal operation	---	Compressor frequency
Error or protection	Placeholder and error or protection code	
In menu mode	Display menu mode code	
System check	Display system check code	

6.2.2 Function of buttons SW3 to SW6

Table 6.2

Button	Function
SW3 (UP)	In menu mode: previous and next buttons for menu modes.
SW4 (DOWN)	Not in menu mode: previous and next buttons for system check information.
SW5 (MENU)	Enter / exit menu mode.
SW6 (OK)	Confirm to enter specified menu mode.

6.2.3 Menu mode

Only master unit has the full menu functions, slaves units only have error codes check and cleaning functions.

1. Long press SW5 "MENU" button for 5 seconds to enter menu mode, and the digital display displays "n0".
2. Press SW3 / SW4 "UP / DOWN" button to select the first level menu "n1", "n2", "n3", "n4" or "nb".
3. Press SW6 "OK" button to enter specified first level menu, for example, enter "n4" mode.
4. Press SW3 / SW4 "UP / DOWN" button to select the second level menu from "n41" to "n45".
5. Press SW6 "OK" button to enter specified second level menu, for example, enter "n42" mode.
6. Press SW3 / SW4 "UP / DOWN" button to select the specified menu mode code.
7. Press SW6 "OK" button to enter specified menu mode.

⚠ CAUTION

- Operate the switches and push buttons with an insulated stick (such as a closed ball-point pen) to avoid touching of live parts.

Menu mode selection flowchart:

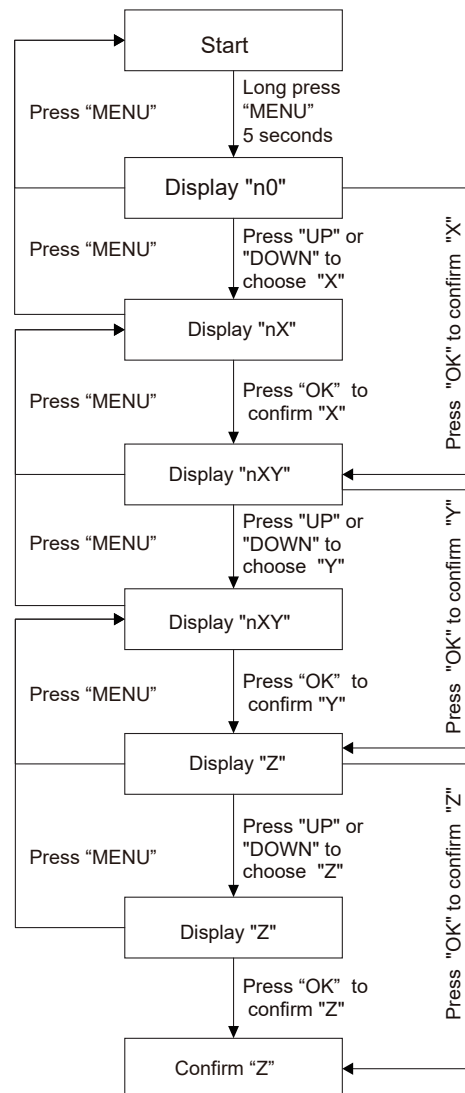

Table 6.3

First level menu	Second level menu	Specified menu mode	Description	Default
n0	0	0	History error	-
		1	Cleaning history error	
	1	0	Query Indoor unit's address	
		2	Query Power OFF Indoor unit's address	
	2	1	Driver's version (compressor and fan displayed in turn)	
n1	0	-	Shield C26 and C28 error in 3 hours	-
	1	0	Cooling Test	
		1	Heating Test	
		2	Test running	
	2	0	Refrigerant recovery to outdoor unit	
		1	Refrigerant recovery to indoor unit	
		2	Balance system refrigerant	
	3	0	Manual refrigerant charge	
		1	Auto refrigerant charge	
5	-	Vacuum mode		
6	-	Set VIP indoor unit address		
n2	0	0	Automatic priority mode	√
		1	Cooling priority mode	-
		2	VIP priority mode or voting priority mode	
		3	In response to heating mode only	
		4	In response to cooling mode only	
		5	Heating priority mode	
		6	Change over	
		7	Voting priority mode	
		8	First on priority mode	
		9	Capability requirements priority mode	
	1	0	Non silent mode	
		1	Silent mode 1	-
		2	Silent mode 2	
		3	Silent mode 3	
		4	Silent mode 4	
		5	Silent mode 5	
		6	Silent mode 6	
		7	Silent mode 7	
		8	Silent mode 8	
		9	Silent mode 9	
		A	Silent mode 10	
		b	Silent mode 11	
		C	Silent mode 12	
		d	Silent mode 13	
	E	Silent mode 14		
	2	0	0Pa static pressure	√
		1	20Pa static pressure	-
2		40Pa static pressure		
3		60Pa static pressure		
4		80Pa static pressure		

First level menu	Second level menu	Specified menu mode	Description	Default
n2	3	40	Power limitation mode, Maximum current =MCA * setting value	-
		41		
		42		
		~		
		98		
		99		
		100		√
	4	0	Midea ETA function unavailable	-
		1	Midea ETA function available	√
	5	0	Celsius unit	√
		1	Fahrenheit unit	-
	7	0	Auto dust-clean function unavailable	√
		1	Auto dust-clean function available	-
	8	0	Dry contact closing effective	√
1		Dry contact opening effective	-	
n3	2	0	0m level difference between indoor unit and outdoor unit	√
		1	20m level difference between indoor unit and outdoor unit	
		2	40m level difference between indoor unit and outdoor unit	
		3	50m level difference between indoor unit and outdoor unit	-
	4	0	Normal	√
		1	High sensible heat mode	-
		2	Low temperature mode	
	7	0	Internal ambient temperature sensor	√
1		External ambient temperature sensor	-	
n4	0	-	Outdoor unit address	-
	1	-	Network address	0
	2	-	Number of indoor units	1
	4	0	Auto addressing	-
		1	Clear address	
	5	0	V8 communication protocol RS-485 (P Q) communication)	√
		1	Non-V8 communication protocol RS-485 (P Q E) communication)	
		2	HyperLink (M1 M2) communication -IDUs uniform power supplied	-
3		HyperLink (M1 M2) communication -IDUs separate power supplied		
n5	0	0	Fan backup running unavailable	-
		1	Fan backup running available	√
	1	0	Sensors backup running unavailable	-
		1	Sensors backup running available (Manual)	√
		2	Sensors backup running available (Automatic)	
	2	0	Backup operation time setting (1 day)	-
		1	Backup operation time setting (2 days)	
		2	Backup operation time setting (3 days)	
		3	Backup operation time setting (4 days)	
		4	Backup operation time setting (5 days)	
		5	Backup operation time setting (6 days)	
		6	Backup operation time setting (7 days)	

First level menu	Second level menu	Specified menu mode	Description	Default
n8	7	0	Non stop compressor defrosting	√
		1	Stop compressor defrosting	-
n9	5	-	Release central controller emergency stop	-
	7	0	Digital electricity meter	√
		1	Pulse electricity meter	-
nc	0	0	Dry contact 1 function selection (Cooling only)	
		1	Dry contact 1 function selection (Heating only)	-
		2	Dry contact 1 function selection (Force incapacity requirements)	
		3	Dry contact 1 function selection (Force stop)	√
	1	0	Dry contact 2 function selection (Cooling only)	
		1	Dry contact 2 function selection (Heating only)	-
		2	Dry contact 2 function selection (Force incapacity requirements)	
		3	Dry contact 2 function selection (Force stop)	√
	2	0	Dry contact 3 function selection (Operation signal)	-
		1	Dry contact 3 function selection (Alarm signal)	√
		2	Dry contact 3 function selection (Compressor running signal)	
		3	Dry contact 3 function selection (Defrosting signal)	-
		4	Dry contact 3 function selection (Refrigerant leakage signal)	

6.2.4 UP / DOWN system check button

Before pressing UP or DOWN button, allow the system to operate steadily for more than an hour. On pressing UP or DOWN button, the parameters listed in below table will be displayed in sequence.

Table 6.4

DISP.	CONTENT	DISCRIPTION
--	Standby	(ODU address+ IDU quantity)/frequency/special status
0	ODU address	0~3
1	ODU capacity	Unit: HP
2	Quantity of ODUs	1~4 (1)
3	Quantity of IDUs	1~64 (1)
4	Total capacity of ODU system	Displayed on master ODU only (2)
5	Target frequency of this ODU	Displacement frequency (3)
6	Target frequency of ODU system	Displacement frequency=DISP. ×10
7	Actual frequency of compressor	Actual frequency
8	Reserved	
9	Operating mode	[0] OFF
		[2] Cooling
		[3] Heating
10	Fan speed 1	Unit: RPM
11	Fan speed 2	Unit: RPM
12	T2 average	Actual temperature=DISP. Unit: C
13	T2B average	Actual temperature=DISP. Unit: C
14	T3	Actual temperature=DISP. Unit: C
15	T4	Actual temperature=DISP. Unit: C
16	T5	Actual temperature=DISP. Unit: C
17	T6A	Actual temperature=DISP. Unit: C
18	T6B	Actual temperature=DISP. Unit: C
19	T7C1	Actual temperature=DISP. Unit: C
20	Reserved	
21	T71	Actual temperature=DISP. Unit: C
22	Reserved	Actual temperature=DISP. Unit: C
23	T8	Actual temperature=DISP. Unit: C
24	NTC_max	Actual temperature=DISP. Unit: C
25	T9 (Reserved)	Actual temperature=DISP. Unit: C
26	TL	Actual temperature=DISP. Unit: C
27	Discharge superheat degree	Actual temperature=DISP. Unit: C
28	Primary current	Actual current=DISP./10 Unit: A
29	Inverter compressor current	Actual current=DISP./10 Unit: A
30	Reserved	
31	EEVA position	Actual value=DISP. *24
32	Reserved	
33	EEVC position	Actual value=DISP. *4
34	EEVE position	Actual value=DISP. *4
35	High pressure of unit (MPa)	Actual pressure=DISP. /100
36	Low pressure of unit (MPa)	Actual pressure=DISP. /100
37	Quantity of online IDUs	Actual quantity
38	Quantity of running IDUs	Actual quantity

39	Heat exchanger status	[0] OFF
		[1] C1: Condenser. Running
		[2] D1: Condenser. Not running
		[3] D2: Reserved
		[4] E1: Evaporator. Running
		[5] F1: Reserved
		[6] F2: Evaporator. Not running
40	Special mode	[0] Not in special mode
		[1] Oil return
		[2] Defrost
		[3] Startup
		[4] Stop
		[5] Quick check
		[6] Self cleaning
41	Silent mode setting	0~14, 14 represents the most silent
42	Static pressure mode	[0] 0Pa
		[1] 20Pa
		[2] 40Pa
		[3] 60Pa
		[4] 80Pa
43	Tes (Target evaporating temperature)	Actual temperature=DISP. Unit: °C
44	Tcs (Target condensing temperature)	Actual temperature=DISP. Unit: °C
45	DC voltage	Actual voltage Unit: V
46	AC voltage	Actual voltage Unit: V
47	Quantity of cooling mode IDUs	
48	Quantity of heating mode IDUs	
49	Capacity of cooling mode IDUs	
50	Capacity of heating mode IDUs	
51	Refrigerant volume	[0] No result
		[1] Critically insufficient
		[2] Significantly insufficient
		[3] Normal
		[4] Slightly excessive
		[5] Significantly excessive
52	Dirty blockage rate	0~10, 10 represents the worst
53	Fan error	
54	Software version	
55	Last error code	
56	Reserved	
57	Reserved	
58	Reserved	

(1) Available for master unit.

(2) Only available for master unit, displayed on slave units has no sense.

(3) Need to convert to current compressor output volume, example: compressor output volume is 98, Target frequency = Actual frequency * 98 / 60.

7 COMMISSIONING

7.1 Overview

After installation, and once the field settings have been defined, the installation personnel is obliged to verify the correctness of the operations. Follow the steps below to perform the test run.

This chapter describes how the test run can be carried out once the installation is complete, and other relevant information.

The test run usually includes the following stages:

1. Review the "Checklist Before Test Run".
2. Implement the test run.
3. Correct the errors before the test run.
4. Run the system.

7.2 Precautions When Commissioning

⚠ WARNING

During the test run, the outdoor unit operates at the same time with indoor units connected to it. It is very dangerous to commission indoor units during the test run.

Do not insert fingers, sticks, or other items into the air inlet or outlet. Do not remove the fan mesh cover.

💡 NOTE

Note that the required input power may be higher when this unit is run for the first time. This phenomenon is due to the compressor which needs to run for 50 hours before it can achieve a stable operating and power consumption state. Make sure the power supply is turned on 12 hours before operations so that the crankcase heater is properly energized. This is also to protect the compressor.

i INFORMATION

The test run can be carried out when the ambient temperature is within the required range as Fig.7-1.

Avg. indoor temperature °C

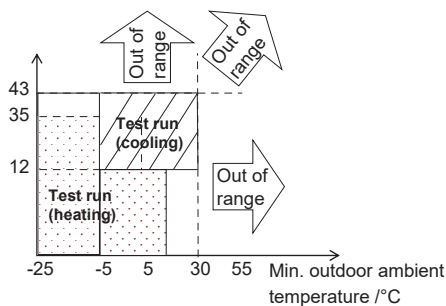

Fig.7.1

During the test run, the outdoor units and indoor units will start at the same time. Make sure all the preparations for the outdoor units and indoor units have been completed.

7.3 Checklist Before Commissioning

Once this unit is installed, check the following items first. After all the following checks have been completed.

<input type="checkbox"/>	Installation Check if the unit is installed correctly to prevent strange noises and vibrations when the unit starts.
<input type="checkbox"/>	Field wiring Based on the wiring schematic and the relevant regulations, make sure the field wiring is based on the instructions described in section 5.10 on connecting wires.
<input type="checkbox"/>	Earth wirings Make sure the earth wirings is connected correctly, and the earthing terminal is tight.
<input type="checkbox"/>	Insulation test of main circuit Use the megameter of 500V, apply a voltage of 500V DC between the power terminal and the earth terminal. Check that the insulation resistance is above 2 MΩ. Do not use the megameter on the transmission line.
<input type="checkbox"/>	Fuses, circuit breakers, or protection devices Check that the fuses, circuit breakers, or locally installed protection devices comply with the size and type specified in section 4.4.2 on the requirements for safety devices. Make sure you use fuses and protection devices.
<input type="checkbox"/>	Internal wiring Visually inspect if the connections between the electrical component box and the interior of the unit is loose, or if the electrical components are damaged.
<input type="checkbox"/>	Piping dimensions and insulation Make sure the installation piping dimensions are correct, and the insulation work can be carried out normally.
<input type="checkbox"/>	Stop valve Make sure the stop valve is open on both the liquid, low pressure and high pressure gas sides.
<input type="checkbox"/>	Equipment damage Check for damaged components and extruded piping inside the unit.
<input type="checkbox"/>	Refrigerant leak Check for refrigerant leaks inside the unit. If there is a refrigerant leak, try to repair the leak. If the repair is not successful, please call the local dealer. Do not come in contact with the refrigerant leaking from the refrigerant piping connections. It may cause frostbite.
<input type="checkbox"/>	Oil leak Check if there is oil leaking from the compressor. If there is an oil leak, try to repair the leak. If the repair is not successful, please call the local dealer.
<input type="checkbox"/>	Air inlet/outlet Check for paper, cardboard or any other material that may obstruct the air inlet and outlet of the equipment.
<input type="checkbox"/>	Add additional refrigerant The amount of refrigerant to be added to this unit should be marked on the "Confirmation Table" which is placed at electrical control box front cover.
<input type="checkbox"/>	Installation date and field settings Make sure the installation date is recorded on the label of the electric control box cover, and the field settings are recorded as well.

7.4 About Test Run

i INFORMATION

- Before you start the compressor, it may take 10 minutes to achieve a uniform cooling state.
- During the test run, the sound of the cooling mode in operation or the solenoid valve may become louder, and there may be changes in the displayed indicators. This is not a malfunction.

7.5 Test Run Implementation

1. Make sure all the settings you need to configure are completed. See section 6.2 on the implementation of the field settings.
2. Turn on the power supply of the outdoor unit and the indoor units.

i INFORMATION

Make sure the power supply is turned on 12 hours before operations so that the crankcase heater is properly energized. This is also to protect the compressor.

Specific procedures for the test run are as follows:

Step 1: Power on

Cover the lower panel of the ODU, and power on all IDUs and ODUs.

Step 2: Enter commissioning mode

When the ODU is first powered on, it displays "-. -. -. -. ", which means the unit is not commissioned.

Long press the "DOWN" and "UP" buttons simultaneously for 5s on the master ODU to enter commissioning mode.

Step 3: Set the number of IDUs in a system

The digital display of the master ODU displays "01 01", where 1st and 2nd digits always on, 3rd and 4th digits flashing. The 3rd and 4th digits represent the number of IDUs, the initial value is 1, short press the "DOWN" or "UP" button to change the number.

Once the number of IDUs has been set, short press the "OK" button to confirm and automatically proceed to the next step.

Step 4: Select the system communication protocol

Enter the communication protocol setting interface, the digital display of master ODU displays "02 0", where the 1st and 2nd digits always on, the 3rd digit off, the 4th digit flashing. The 4th digit of the digital display represents the communication protocol type, the initial value is 0. Short press the "DOWN" or "UP" button to change the communication protocol.

If the system is all V8 IDUs, and the IDUs and ODUs are connected by PQ communication, please select V8 protocol RS-485 (P Q) communication, and set the 4th

digit of the master ODU digital display to 0; ODU factory default V8 protocol RS-485 (P Q) communication.

If the system has a non-V8 IDUs, and the IDUs and ODUs are connected by PQE communication, please select the non-V8 protocol RS-485 (P Q E) communication and set the 4th digit of the master ODU digital display to 1.

If the system is all V8 IDUs, the IDUs and ODUs are connected by M1M2 communication, and all IDUs are powered uniformly, please select the HyperLink (M1M2) communication + indoor unit unified power supply, and set the 4th digit of the master ODU digital display to 2.

If the system is all V8 IDUs, the IDUs and ODUs are connected by M1M2 communication, and there is separate power supply for IDUS, please select the HyperLink (M1M2) communication + indoor unit separate power supply, and set the 4th digit of the master ODU digital display to 3.

Once the communication protocol has been set, short press the "OK" button to confirm and automatically proceed to the next step.

Step 5: IDUs and ODUs address setting

Enter the auto addressing function, the digital display of master ODU flashes "AU Ad" and "X YZ" in rotation. "AU Ad" means the auto addressing is in progress, "X" represents the address of the ODU, "YZ" represents the number of detected IDUs; the auto addressing takes about 5-7 minutes, and automatically proceed to the next step after completion.

Step 6: System initialization

Entering system initialization, the digital display of master ODU flashes "AU Ad" and "X YZ" in rotation. "INIT" means initialization is in progress, "X" represents the address of the ODU, "YZ" represents the number of detected IDUs; the system initialization takes about 3-5 minutes, and automatically proceed to the next step after completion.

Step 7: Tset Run

During a test run, the system automatically diagnoses the air outlet static pressure of the ODU, the stop valve status, the consistency of the refrigerant piping and communication wiring, and the installation environment. For a properly installed and connected system, the test run will last for about 40 to 60 minutes. In this process, the ODU digital display will show "STP1" to "STP7". After the test run, the digital display will show "End", 10 seconds after which the system will automatically proceed to the next step.

In case of an abnormal shutdown of the ODU during the test run, the digital display will show the error code. Please troubleshoot according to the troubleshooting guide. After troubleshooting, the test run will restart through the menu "n11-2" on the master unit until the digital display shows "End" and the system proceeds to the next step. Then, the test run is completed.

Step 8: Complete

Upon completion of the test run, the system will enter the standby mode, and the digital display will show "X YZ" where X represents the ODU address and YZ represents the number of IDU(s) detected. Then, the unit can start properly.

commissioning flow chart

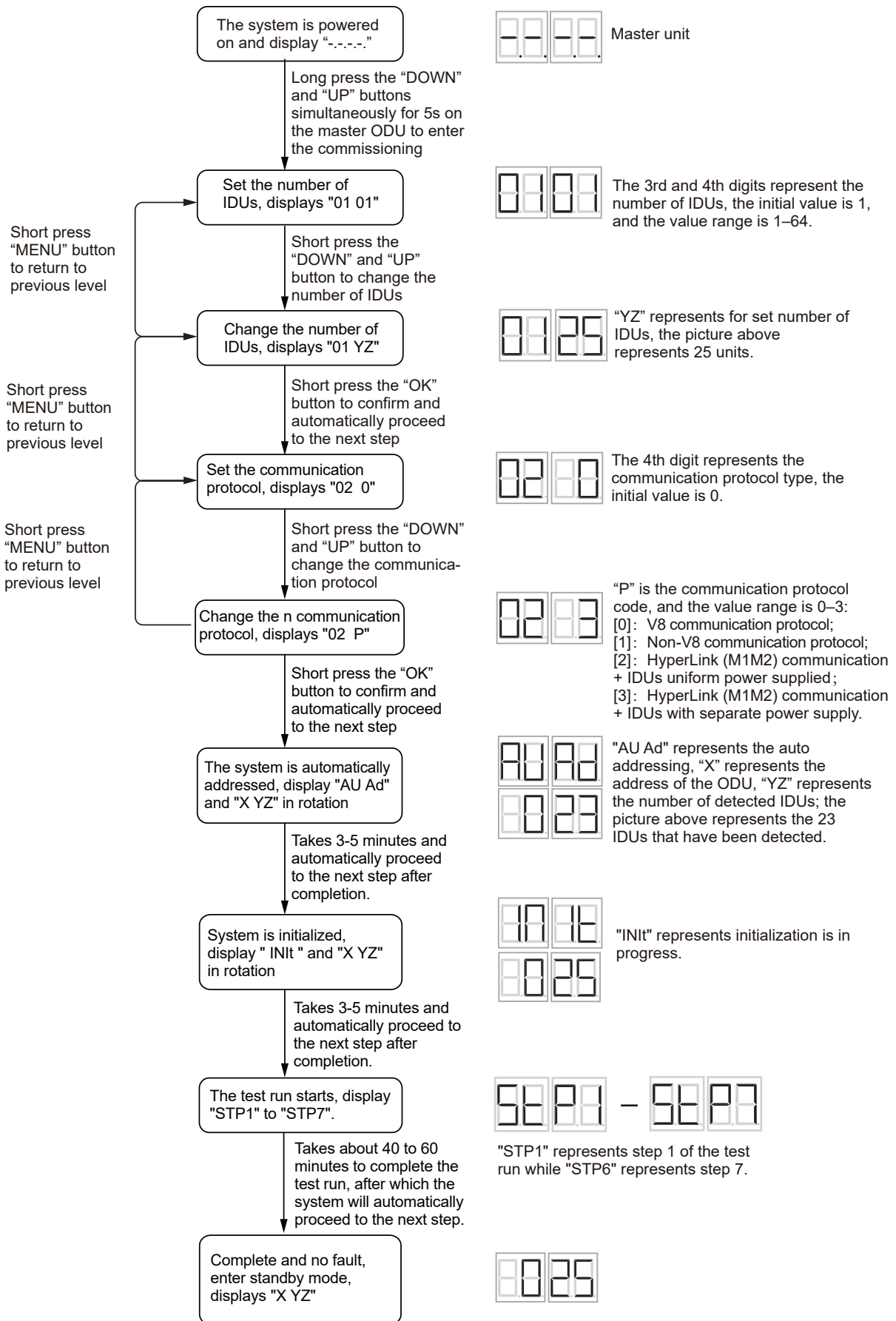

7.6 Correcting After Abnormal Completion Of Test Run

The test run is considered complete when there is no error code on the user interface or the outdoor unit display. When an error code is displayed, correct the operation based on the description in the error code table. Try to conduct the test run again to check that the exception has been corrected.

i INFORMATION

Refer to the installation manual of the indoor unit for details on other error codes related to the indoor unit.

7.7 Operating This Unit

Once the installation of this unit is completed, and the test run of the outdoor and indoor units is done, you can start to run the system.

The indoor unit user interface should be connected to facilitate the operations of the indoor unit. Please refer to the installation manual of the indoor unit for more details.

8 MAINTENANCE AND REPAIR

i INFORMATION

Arrange for the installation personnel or service dealer to carry out one maintenance every year.

8.1 Overview

This chapter contains the following information:

- Take electrical hazards preventive measures during system maintenance and repair.

8.2 Safety Precautions

NOTE

Before carry out any maintenance or repair work, touch the metal parts of the unit to dissipate static electricity and protect the PCB.

8.2.1 Prevent electrical hazards

When maintaining and repairing the inverter module

1. Do not open the cover of the electrical component box within 5 minutes after the power is switched off.
2. Verify that the power supply is switched off before you use the measuring instrument to measure the voltage between the main capacitor and the main terminal ensure that the capacitor voltage in the main circuit is less than 36 VDC. the position of main terminal have be shown in the Wiring nameplate(The port of CN38 on the inverter module board).

3. Pull out the plug connecting to the power cord of the fan to prevent the fan from rotating when it is windy outside. The strong winds will cause the fan to rotate and generate electricity which can charge the capacitor or terminals, leading to an electric shock. At the same time, do take note of any mechanical damage. The blades of a high speed rotating fan are very dangerous and cannot be operated by one person alone.

4. Once the maintenance or repair is completed, remember to reconnect the plug to the terminal; otherwise, a fault will be reported for the main control board.

5. When the unit is power on, the fan of the unit with auto snow-blowing function will run periodically, so make sure the power supply is off before touching the unit.

Please refer to the wiring schematic on the unit.

9 TECHNICAL DATA

9.1 Dimensions

NOTE

- Product dimension may slight differ for different panel used, tolerance range $\pm 30\text{mm}$, the actual size prevail to your purchasing.
- Product picture on the page is for reference only.

8-14HP

Unit: mm

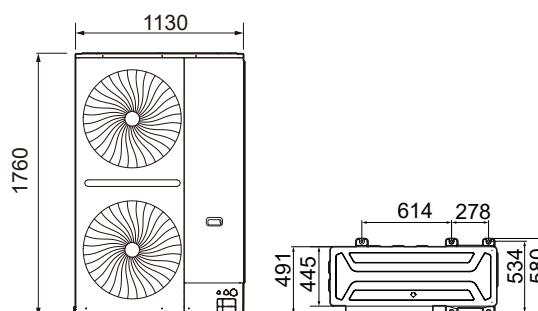

Fig. 9.1

16-22HP

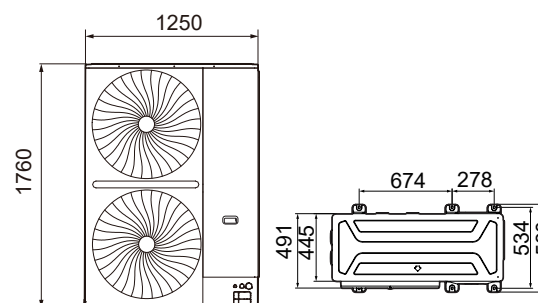

Fig. 9.2

9.2 Component Layout And Refrigerant Circuits

8-14 HP

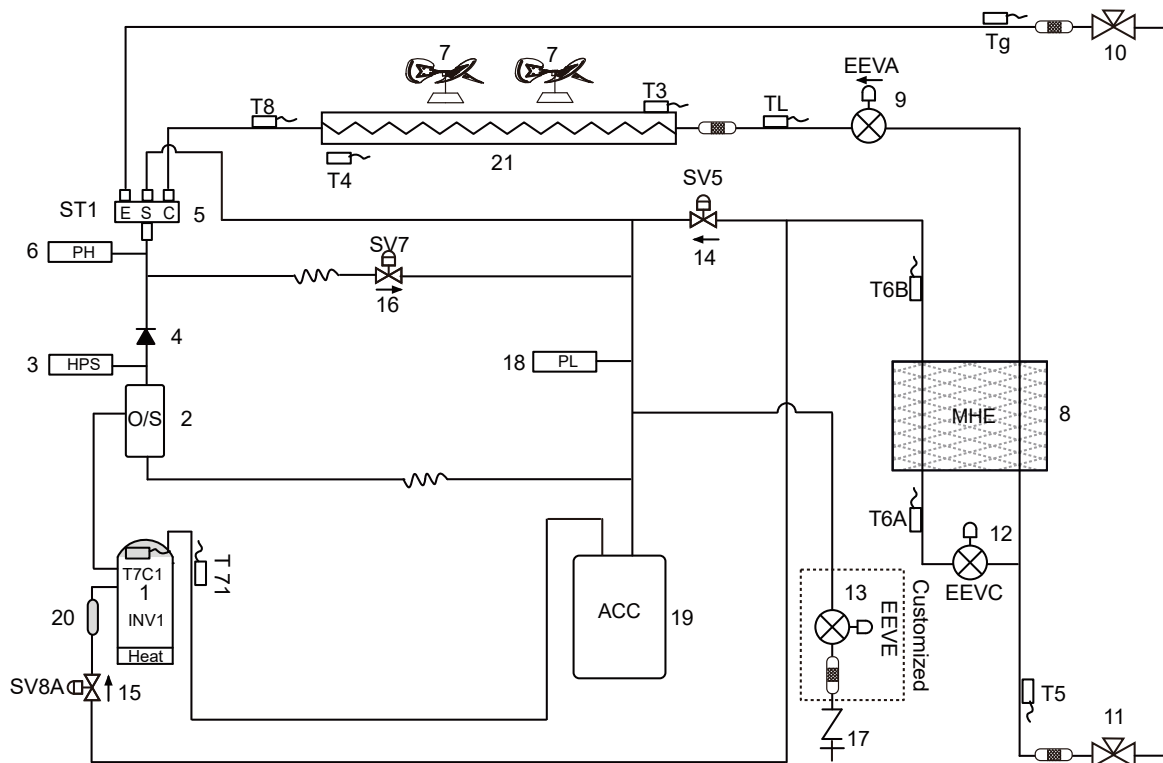

Fig. 9.3

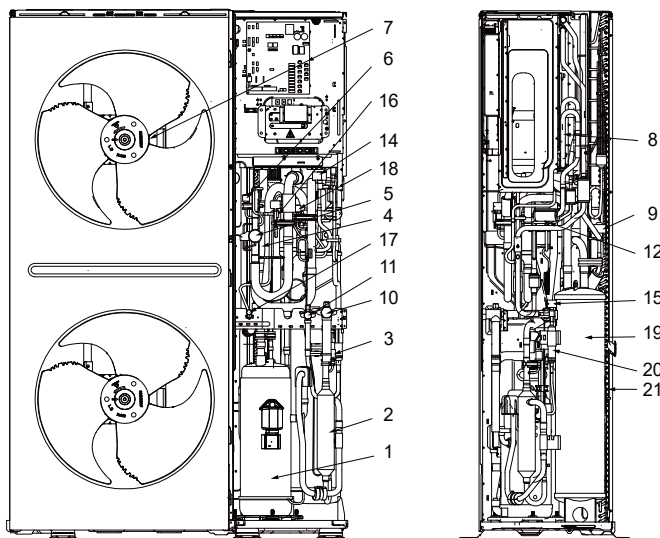

Fig 9.4

Table 9.2

Legend	
T3	Main exchanger pipe temperature sensor
T4	Outdoor ambient temperature sensor
T5	Liquid stop valve inlet temperature sensor
T6A	Microchannel heat exchanger inlet temperature sensor
T6B	Microchannel heat exchanger outlet temperature sensor
T7C1	Discharge temperature sensor
T71	Suction temperature sensor
T8	Condenser inlet temperature sensor
TL	Condenser outlet temperature sensor
Tg	Gas pipe temperature sensor

Table 9.1

Legend	
No.	Parts name
1	Inverter compressor
2	Oil separator
3	High pressure switch
4	Check valve
5	4-way valve
6	High pressure sensor
7	Inverter fan
8	Microchannel heat exchanger
9	Electronic expansion valve (EEVA)
10	Stop valve (gas side)
11	Stop valve (liquid side)
12	Electronic expansion valve (EEVC)
13	Electronic expansion valve (Optional EEVE)
14	Injection bypass solenoid valve(SV5)
15	Compressor vapor injection valve (SV8A)
16	Hot gas bypass solenoid valve(SV7)
17	Charge port
18	Low pressure sensor
19	Gas-liquid separator
20	Muffler
21	Heat exchanger

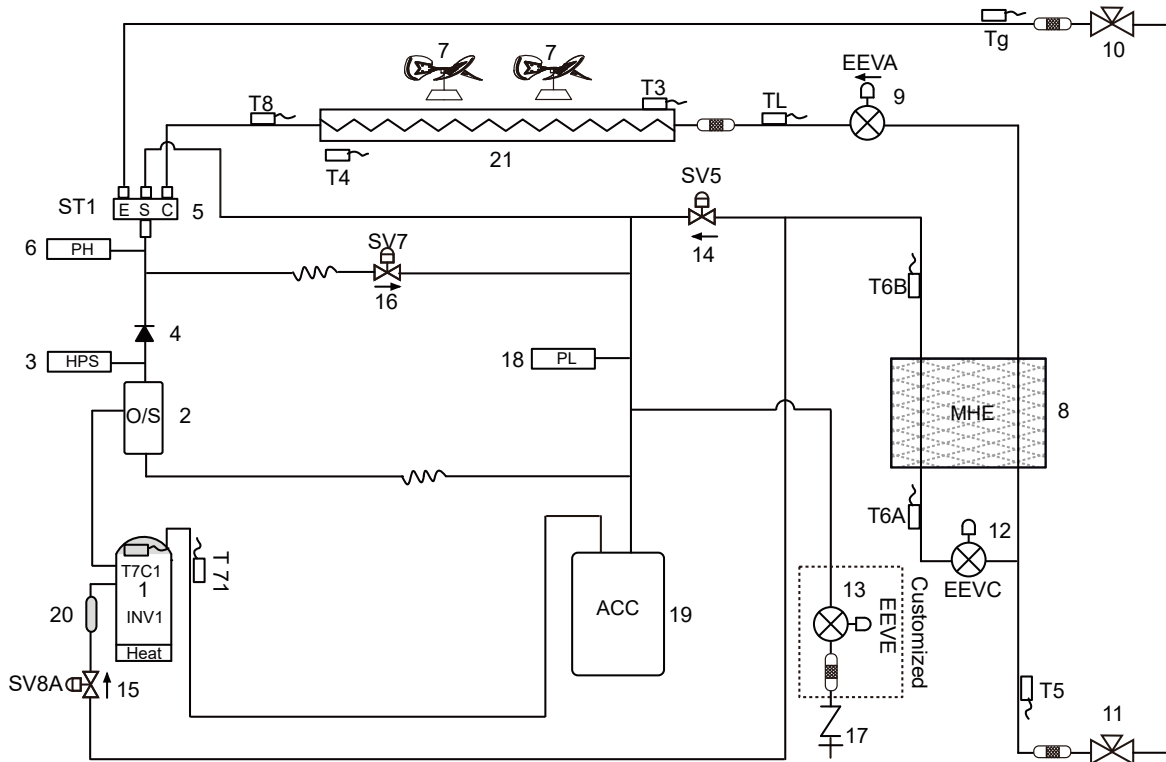

Fig 9.5

Table 9.3

Legend	
No.	Parts name
1	Inverter compressor
2	Oil separator
3	High pressure switch
4	Check valve
5	4-way valve
6	High pressure sensor
7	Inverter fan
8	Microchannel heat exchanger
9	Electronic expansion valve (EEVA)
10	Stop valve (gas side)
11	Stop valve (liquid side)
12	Electronic expansion valve (EEVC)
13	Electronic expansion valve (Optional EEVE)
14	Injection bypass solenoid valve (SV5)
15	Compressor vapor injection valve (SV8A)
16	Hot gas bypass solenoid valve (SV7)
17	Charge port
18	Low pressure sensor
19	Gas-liquid separator
20	Muffler
21	Heat exchanger

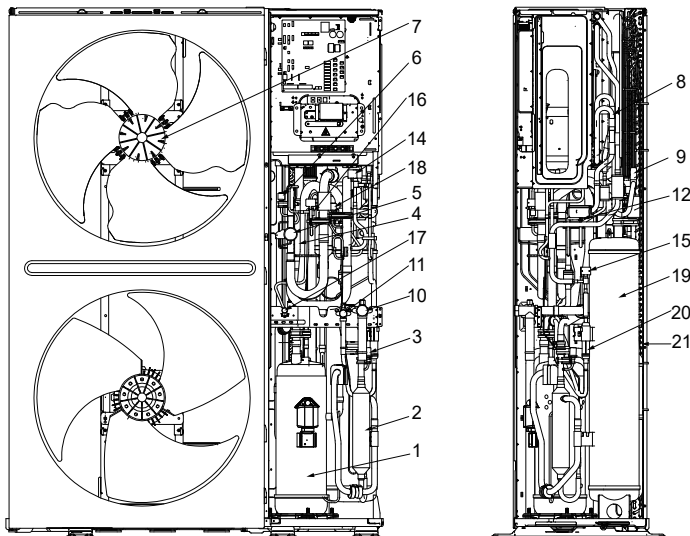

Fig 9.6

Table 9.4

Legend	
T3	Main exchanger pipe temperature sensor
T4	Outdoor ambient temperature sensor
T5	Liquid stop valve inlet temperature sensor
T6A	Microchannel heat exchanger inlet temperature sensor
T6B	Microchannel heat exchanger outlet temperature sensor
T7C1	Discharge temperature sensor
T71	Suction temperature sensor
T8	Condenser inlet temperature sensor
TL	Condenser outlet temperature sensor
Tg	Gas pipe temperature sensor

NOTE

There is no SV8A for 20HP to 22HP outdoor units.

9.3 Outdoor Unit Ducting

The following principles shall be followed when installing the air guide device:

- The addition of louvers will affect the air output of the unit, so the use of louvers is not recommended. If you want to use it, please control the shutter angle below 15° and ensure that the effective opening rate of the shutter is more than 90%.
- The exhaust duct of each fan must be installed independently. It is forbidden to assemble the exhaust hood between machines in parallel in any form, otherwise it may cause unit failure.
- Please install a soft connection between the machine and the air duct to prevent vibration and noise.
- Circular flexible air duct must be used for installation.

The Recommended diameters of Circular flexible air ducts:

Table 9.5

HP	Diameters of Grille (mm)	Minimum diameters of air ducts(mm)
8~14HP	665	≥700
16~22HP	793	≥820

The installation of circular flexible air ducts

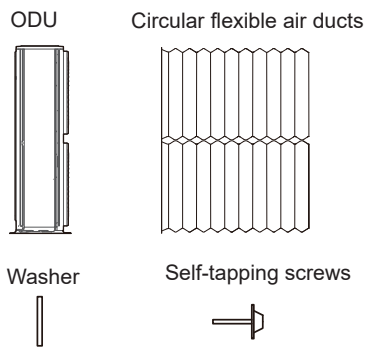

Fig.9.7

Fixing Circular flexible air ducts on the front panel by self-tapping screws.

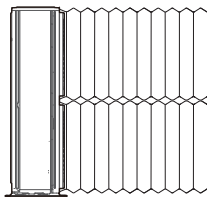

Fig.9.8

There are advised to use 8 self-tapping screws, and the position showing as fig.9.9.

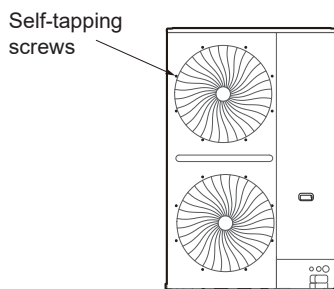
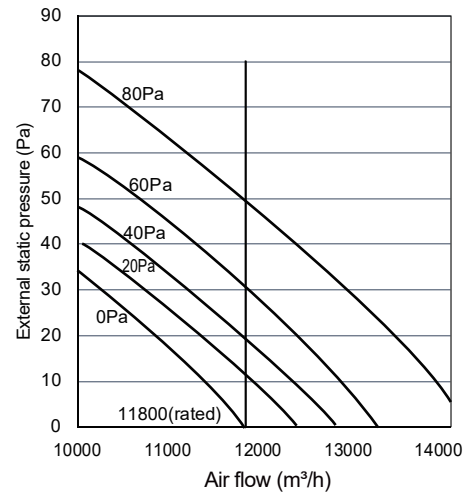

Fig.9.9

9.4 Fan Performance

8HP Fan characteristics Curve



10HP Fan characteristics Curve

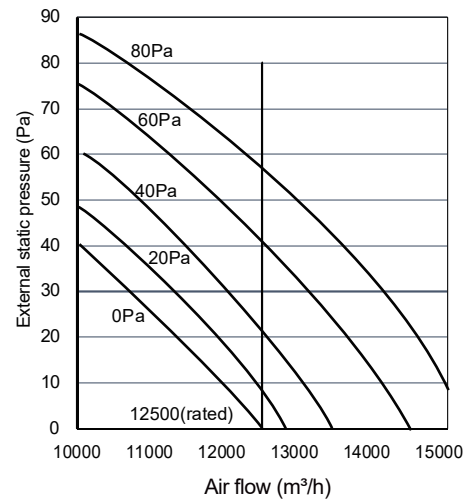

12HP Fan characteristics Curve

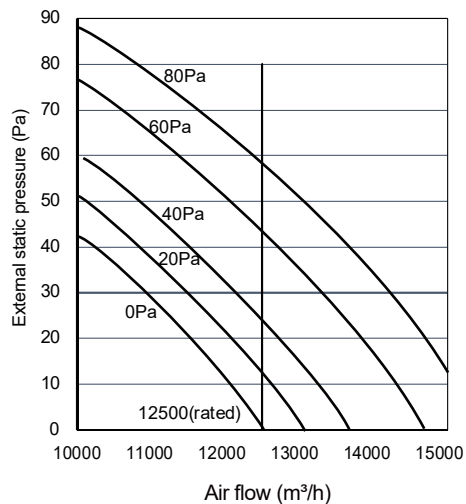

14HP Fan characteristics Curve

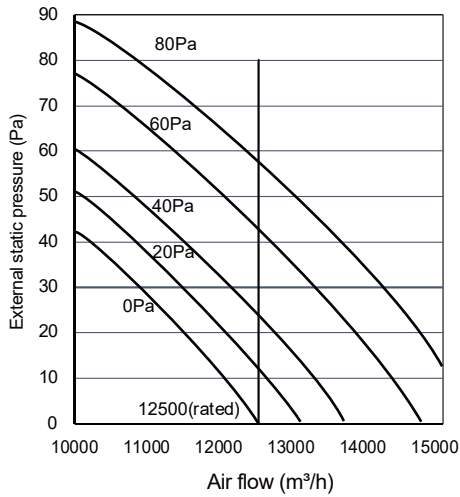

20HP Fan characteristics Curve

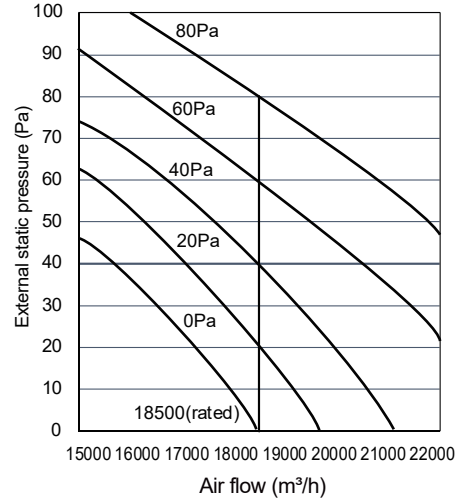

16HP Fan characteristics Curve

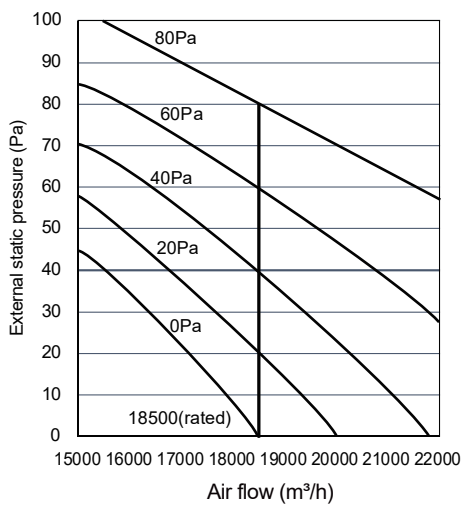

22HP Fan characteristics Curve

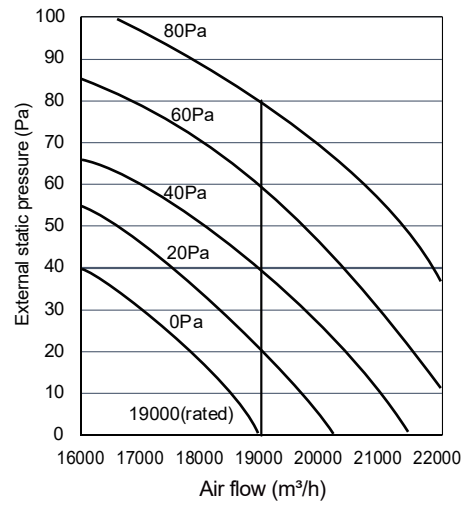

18HP Fan characteristics Curve

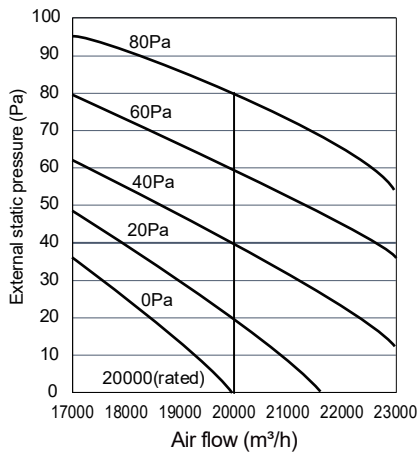

NOTE

- These fan characteristics Curve above including both standard models and high static pressure models.
- Standard models can provide 35Pa maximum external static pressure. High static pressure models can provide 80Pa maximum external static pressure.
- If the external static pressure you needed over 35Pa, please contact us by suppliers for customized high static pressure models.

9.5 Erp information

8HP

Cooling mode:

Information requirements for air-to-air conditioners								
Model(s): MV8S-252WV2RN1								
Test matching indoor units form, cassette: 2×MIH45Q4N18+MIH80Q4N18+MIH90Q4N18								
Outdoor side heat exchanger of air conditioner: air								
Indoor side heat exchanger of air conditioner: air								
Type: compressor driven								
Driver of compressor: electric motor								
Item	Symbol	Value	Unit		Item	Symbol	Value	Unit
Rated cooling capacity	P _{rated,c}	25.20	kW		Seasonal space cooling energy efficiency	η _{s,c}	287.0	%
Declared cooling capacity for part load at given outdoor temperatures T _j and indoor 27/19°C (dry/wet bulb)				Declared energy efficiency ratio or gas utilisation efficiency /auxiliary energy factor for part load at given outdoor temperatures T _j				
T _j =+35°C	P _{dc}	25.20	kW		T _j =+35°C	EER _d	3.30	--
T _j =+30°C	P _{dc}	18.57	kW		T _j =+30°C	EER _d	4.97	--
T _j =+25°C	P _{dc}	11.94	kW		T _j =+25°C	EER _d	8.41	--
T _j =+20°C	P _{dc}	8.42	kW		T _j =+20°C	EER _d	15.20	--
Degradation co-efficient for air conditioners(*)								
	C _{dc}	0.25	--					
Power consumption in modes other than "active mode"								
Off mode	P _{OFF}	0.005	kW		Crankcase heater mode	P _{CK}	0.04	kW
Thermosat-off mode	P _{TO}	0.005	kW		Standby mode	P _{SB}	0.005	kW
Other items								
Capacity control	variable				For air-to-air air conditioner: air flow rate, outdoor measured	--	11800	m ³ /h
Sound power level, outdoor	L _{WA}	76	dB					
GWP of the refrigerant		2088	kg CO ₂ eq (100years)					
Contact details								
(*)If C _{dc} is not determined by measurement, then the default degradation coefficient of heat pumps shall be 0.25.								
Where information relates to multi-split air conditioners, the test result and performance data may be obtained on the basis of performance of the outdoor unit, with a combination of indoor unit(s) recommended by the manufacturer or importer.								

8HP

Heating mode:

Information requirements for heat pumps							
Model(s): MV8S-252WV2RN1 Test matching indoor units form, cassette: 2×MIH45Q4N18+MIH80Q4N18+MIH90Q4N18							
Outdoor side heat exchanger of air conditioner: air							
Indoor side heat exchanger of air conditioner: air							
If the heater is equipped with a supplementary heater: no							
Driver of compressor: electric motor							
Parameters shall be declared for the average heating season, parameters for the warmer and colder heating seasons are optional.							
Item	Symbol	Value	Unit	Item	Symbol	Value	Unit
Rated heating capacity	$P_{rated,h}$	25.20	kW	Seasonal space heating energy efficiency	$\eta_{s,h}$	163.0	%
Declared heating capacity for part load at indoor temperature 20°C and outdoor temperatures T_j				Declared coefficient of performance or gas utilisation efficiency/auxiliary energy factor for part load at given outdoor temperatures T_j			
$T_j=-7^\circ\text{C}$	P_{dh}	12.12	kW	$T_j=-7^\circ\text{C}$	COP_d	2.92	--
$T_j=+2^\circ\text{C}$	P_{dh}	7.38	kW	$T_j=+2^\circ\text{C}$	COP_d	3.66	--
$T_j=+7^\circ\text{C}$	P_{dh}	4.74	kW	$T_j=+7^\circ\text{C}$	COP_d	5.90	--
$T_j=+12^\circ\text{C}$	P_{dh}	4.92	kW	$T_j=+12^\circ\text{C}$	COP_d	8.60	--
T_{biv} =bivalent temperature	P_{dh}	13.70	kW	T_{biv} =bivalent temperature	COP_d	2.35	--
T_{OL} =operation temperature	P_{dh}	13.70	kW	T_{OL} =operation temperature	COP_d	2.35	--
Bivalent temperature	T_{biv}	-10	°C				
Degradation co-efficient for heat pumps(**)	C_{dh}	0.25	--				
Power consumption in modes other than "active mode"				Supplementary heater			
Off mode	P_{OFF}	0.005	kW	Back-up heating capacity(*)	e_{lbu}	0.04	kW
Thermosat-off mode	P_{TO}	0.005	kW	Type of energy input			
Crankcase heater mode	P_{CK}	0.04	kW	Standby mode	P_{sb}	0.005	kW
Other items							
Capacity control	variable			For air-to-air heat pump: air flow rate, outdoor measured	--	11800	m ³ /h
Sound power level,outdoor	LWA	76	dB				
GWP of the refrigerant		2088	kg CO ₂ eq (100years)				
Contact details							
(*)							
(**)If C_{dh} is not determined by measurement, then the default degradation coefficient of heat pumps shall be 0.25.							
Where information relates to multi-split heat pumps, xthe test result and performance data may be obtained on the basis of performance of the outdoor unit, with a combination of indoor unit(s) recommended by the manufacturer or importer.							

10HP

Cooling mode:

Information requirements for air-to-air conditioners								
Model(s): MV8S-280WV2RN1 Test matching indoor units form, cassette: MIH45Q4N18 + 3×MIH80Q4N18								
Outdoor side heat exchanger of air conditioner: air								
Indoor side heat exchanger of air conditioner: air								
Type: compressor driven								
Driver of compressor: electric motor								
Item	Symbol	Value	Unit		Item	Symbol	Value	Unit
Rated cooling capacity	$P_{rated,c}$	28.00	kW		Seasonal space cooling energy efficiency	$\eta_{s,c}$	279.0	%
Declared cooling capacity for part load at given outdoor temperatures T_j and indoor 27/19°C (dry/wet bulb)					Declared energy efficiency ratio or gas utilisation efficiency /auxiliary energy factor for part load at given outdoor temperatures T_j			
$T_j=+35^\circ\text{C}$	P_{dc}	28.00	kW		$T_j=+35^\circ\text{C}$	EER_d	3.09	--
$T_j=+30^\circ\text{C}$	P_{dc}	20.63	kW		$T_j=+30^\circ\text{C}$	EER_d	4.80	--
$T_j=+25^\circ\text{C}$	P_{dc}	13.26	kW		$T_j=+25^\circ\text{C}$	EER_d	8.34	--
$T_j=+20^\circ\text{C}$	P_{dc}	8.96	kW		$T_j=+20^\circ\text{C}$	EER_d	14.60	--
Degradation co-efficient for air conditioners(*)								
	C_{dc}	0.25	--					
Power consumption in modes other than "active mode"								
Off mode	P_{OFF}	0.005	kW		Crankcase heater mode	P_{CK}	0.04	kW
Thermosat-off mode	P_{TO}	0.005	kW		Standby mode	P_{SB}	0.005	kW
Other items								
Capacity control	variable				For air-to-air air conditioner: air flow rate, outdoor measured	--	12500	m ³ /h
Sound power level, outdoor	L_{WA}	79	dB					
GWP of the refrigerant		2088	kg CO ₂ eq (100years)					
Contact details								
(*)If C_{dc} is not determined by measurement, then the default degradation coefficient of heat pumps shall be 0.25.								
Where information relates to multi-split air conditioners, the test result and performance data may be obtained on the basis of performance of the outdoor unit, with a combination of indoor unit(s) recommended by the manufacturer or importer.								

10HP

Heating mode:

Information requirements for heat pumps								
Model(s): MV8S-280WV2RN1 Test matching indoor units form, cassette: MIH45Q4N18 + 3×MIH80Q4N18								
Outdoor side heat exchanger of air conditioner: air								
Indoor side heat exchanger of air conditioner: air								
If the heater is equipped with a supplementary heater: no								
Driver of compressor: electric motor								
Parameters shall be declared for the average heating season, parameters for the warmer and colder heating seasons are optional.								
Item	Symbol	Value	Unit		Item	Symbol	Value	Unit
Rated heating capacity	$P_{rated,h}$	28.00	kW		Seasonal space heating energy efficiency	$\eta_{s,h}$	161.4	%
Declared heating capacity for part load at indoor temperature 20°C and outdoor temperatures T_j				Declared coefficient of performance or gas utilisation efficiency/auxiliary energy factor for part load at given outdoor temperatures T_j				
$T_j=-7^\circ\text{C}$	P_{dh}	14.16	kW		$T_j=-7^\circ\text{C}$	COP_d	2.85	--
$T_j=+2^\circ\text{C}$	P_{dh}	8.62	kW		$T_j=+2^\circ\text{C}$	COP_d	4.02	--
$T_j=+7^\circ\text{C}$	P_{dh}	5.54	kW		$T_j=+7^\circ\text{C}$	COP_d	4.91	--
$T_j=+12^\circ\text{C}$	P_{dh}	5.19	kW		$T_j=+12^\circ\text{C}$	COP_d	7.12	--
T_{biv} =bivalent temperature	P_{dh}	16.00	kW		T_{biv} =bivalent temperature	COP_d	2.28	--
T_{OL} =operation temperature	P_{dh}	16.00	kW		T_{OL} =operation temperature	COP_d	2.28	--
Bivalent temperature	T_{biv}	-10	°C					
Degradation co-efficient for heat pumps(**)	C_{dh}	0.25	--		Supplementary heater			
Power consumption in modes other than "active mode"				Supplementary heater				
Off mode	P_{OFF}	0.005	kW		Back-up heating capacity(*)	e_{lbu}	0.04	kW
Thermosat-off mode	P_{TO}	0.005	kW		Type of energy input			
Crankcase heater mode	P_{CK}	0.04	kW		Standby mode	P_{SB}	0.005	kW
Other items								
Capacity control	variable				For air-to-air heat pump: air flow rate, outdoor measured	--	12500	m ³ /h
Sound power level,outdoor	LWA	79	dB					
GWP of the refrigerant		2088	kg CO ₂ eq (100years)					
Contact details								
(*)								
(**)If C_{dh} is not determined by measurement, then the default degradation coefficient of heat pumps shall be 0.25.								
Where information relates to multi-split heat pumps, xthe test result and performance data may be obtained on the basis of performance of the outdoor unit, with a combination of indoor unit(s) recommended by the manufacturer or importer.								

12HP

Cooling mode:

Information requirements for air-to-air conditioners								
Model(s): MV8S-335WV2RN1								
Test matching indoor units form, cassette: 4×MIH45Q4N18 + 2×MIH80Q4N18								
Outdoor side heat exchanger of air conditioner: air								
Indoor side heat exchanger of air conditioner: air								
Type: compressor driven								
Driver of compressor: electric motor								
Item	Symbol	Value	Unit		Item	Symbol	Value	Unit
Rated cooling capacity	$P_{rated,c}$	33.50	kW		Seasonal space cooling energy efficiency	$\eta_{s,c}$	273.4	%
Declared cooling capacity for part load at given outdoor temperatures T_j and indoor 27/19°C (dry/wet bulb)					Declared energy efficiency ratio or gas utilisation efficiency /auxiliary energy factor for part load at given outdoor temperatures T_j			
$T_j=+35^\circ\text{C}$	P_{dc}	33.50	kW		$T_j=+35^\circ\text{C}$	EER_d	2.90	--
$T_j=+30^\circ\text{C}$	P_{dc}	24.68	kW		$T_j=+30^\circ\text{C}$	EER_d	5.19	--
$T_j=+25^\circ\text{C}$	P_{dc}	15.86	kW		$T_j=+25^\circ\text{C}$	EER_d	7.54	--
$T_j=+20^\circ\text{C}$	P_{dc}	8.62	kW		$T_j=+20^\circ\text{C}$	EER_d	14.10	--
Degradation co-efficient for air conditioners(*)								
	C_{dc}	0.25	--					
Power consumption in modes other than "active mode"								
Off mode	P_{OFF}	0.005	kW		Crankcase heater mode	P_{CK}	0.04	kW
Thermosat-off mode	P_{TO}	0.005	kW		Standby mode	P_{SB}	0.005	kW
Other items								
Capacity control	variable				For air-to-air air conditioner: air flow rate, outdoor measured	--	12500	m ³ /h
Sound power level, outdoor	L_{WA}	81	dB					
GWP of the refrigerant		2088	kg CO ₂ eq (100years)					
Contact details								
(*)If C_{dc} is not determined by measurement, then the default degradation coefficient of heat pumps shall be 0.25.								
Where information relates to multi-split air conditioners, the test result and performance data may be obtained on the basis of performance of the outdoor unit, with a combination of indoor unit(s) recommended by the manufacturer or importer.								

12HP

Heating mode:

Information requirements for heat pumps								
Model(s): MV8S-335WV2RN1								
Test matching indoor units form, cassette: 4×MIH45Q4N18 + 2×MIH80Q4N18								
Outdoor side heat exchanger of air conditioner: air								
Indoor side heat exchanger of air conditioner: air								
If the heater is equipped with a supplementary heater: no								
Driver of compressor: electric motor								
Parameters shall be declared for the average heating season, parameters for the warmer and colder heating seasons are optional.								
Item	Symbol	Value	Unit		Item	Symbol	Value	Unit
Rated heating capacity	$P_{rated,h}$	33.50	kW		Seasonal space heating energy efficiency	$\eta_{s,h}$	161.4	%
Declared heating capacity for part load at indoor temperature 20°C and outdoor temperatures T_j					Declared coefficient of performance or gas utilisation efficiency/auxiliary energy factor for part load at given outdoor temperatures T_j			
$T_j=-7^\circ\text{C}$	P_{dh}	16.24	kW		$T_j=-7^\circ\text{C}$	COP_d	2.48	--
$T_j=+2^\circ\text{C}$	P_{dh}	9.89	kW		$T_j=+2^\circ\text{C}$	COP_d	4.15	--
$T_j=+7^\circ\text{C}$	P_{dh}	6.36	kW		$T_j=+7^\circ\text{C}$	COP_d	4.95	--
$T_j=+12^\circ\text{C}$	P_{dh}	5.03	kW		$T_j=+12^\circ\text{C}$	COP_d	7.62	--
T_{biv} =bivalent temperature	P_{dh}	18.37	kW		T_{biv} =bivalent temperature	COP_d	2.27	--
T_{OL} =operation temperature	P_{dh}	18.37	kW		T_{OL} =operation temperature	COP_d	2.27	--
Bivalent temperature	T_{biv}	-10	°C					
Degradation co-efficient for heat pumps(**)								
	C_{dh}	0.25	--		Supplementary heater			
Power consumption in modes other than "active mode"					Back-up heating capacity(*)			
Off mode	P_{OFF}	0.005	kW			e_{lbu}	0.04	kW
Thermosat-off mode	P_{TO}	0.005	kW		Type of energy input			
Crankcase heater mode	P_{CK}	0.04	kW		Standby mode	P_{SB}	0.005	kW
Other items								
Capacity control	variable				For air-to-air heat pump: air flow rate, outdoor measured	--	12500	m ³ /h
Sound power level,outdoor	LWA	81	dB					
GWP of the refrigerant		2088	kg CO ₂ eq (100years)					
Contact details								
(*)								
(**)If C_{dh} is not determined by measurement, then the default degradation coefficient of heat pumps shall be 0.25.								
Where information relates to multi-split heat pumps, xthe test result and performance data may be obtained on the basis of performance of the outdoor unit, with a combination of indoor unit(s) recommended by the manufacturer or importer.								

14HP

Cooling mode:

Information requirements for air-to-air conditioners							
Model(s):MV8S-400WV2RN1							
Test matching indoor units form, cassette: 2×MIH45Q4N18 + 4×MIH80Q4N18							
Outdoor side heat exchanger of air conditioner: air							
Indoor side heat exchanger of air conditioner: air							
Type: compressor driven							
Driver of compressor: electric motor							
Item	Symbol	Value	Unit	Item	Symbol	Value	Unit
Rated cooling capacity	$P_{rated,c}$	40.00	kW	Seasonal space cooling energy efficiency	$\eta_{s,c}$	263.0	%
Declared cooling capacity for part load at given outdoor temperatures T_j and indoor 27/19°C (dry/wet bulb)				Declared energy efficiency ratio or gas utilisation efficiency /auxiliary energy factor for part load at given outdoor temperatures T_j			
$T_j=+35^\circ\text{C}$	P_{dc}	40.00	kW	$T_j=+35^\circ\text{C}$	EER_d	2.54	--
$T_j=+30^\circ\text{C}$	P_{dc}	29.48	kW	$T_j=+30^\circ\text{C}$	EER_d	4.36	--
$T_j=+25^\circ\text{C}$	P_{dc}	18.95	kW	$T_j=+25^\circ\text{C}$	EER_d	8.21	--
$T_j=+20^\circ\text{C}$	P_{dc}	7.88	kW	$T_j=+20^\circ\text{C}$	EER_d	13.60	--
Degradation co-efficient for air conditioners(*)	C_{dc}	0.25	--				
Power consumption in modes other than "active mode"							
Off mode	P_{OFF}	0.005	kW	Crankcase heater mode	P_{CK}	0.04	kW
Thermosat-off mode	P_{TO}	0.005	kW	Standby mode	P_{SB}	0.005	kW
Other items							
Capacity control	variable			For air-to-air air conditioner: air flow rate, outdoor measured	--	12500	m ³ /h
Sound power level, outdoor	L_{WA}	82	dB				
GWP of the refrigerant		2088	kg CO ₂ eq (100years)				
Contact details							
(*)If C_{dc} is not determined by measurement, then the default degradation coefficient of heat pumps shall be 0.25.							
Where information relates to multi-split air conditioners, the test result and performance data may be obtained on the basis of performance of the outdoor unit, with a combination of indoor unit(s) recommended by the manufacturer or importer.							

14HP

Heating mode:

Information requirements for heat pumps								
Model(s):MV8S-400WV2RN1 Test matching indoor units form, cassette: 2×MIH45Q4N18 + 4×MIH80Q4N18								
Outdoor side heat exchanger of air conditioner: air								
Indoor side heat exchanger of air conditioner: air								
If the heater is equipped with a supplementary heater: no								
Driver of compressor: electric motor								
Parameters shall be declared for the average heating season, parameters for the warmer and colder heating seasons are optional.								
Item	Symbol	Value	Unit		Item	Symbol	Value	Unit
Rated heating capacity	P _{rated,h}	40.00	kW		Seasonal space heating energy efficiency	η _{s,h}	163.0	%
Declared heating capacity for part load at indoor temperature 20°C and outdoor temperatures T _j					Declared coefficient of performance or gas utilisation efficiency/auxiliary energy factor for part load at given outdoor temperatures T _j			
T _j =-7°C	P _{dh}	19.47	kW		T _j =-7°C	COP _d	2.51	--
T _j =+2°C	P _{dh}	11.85	kW		T _j =+2°C	COP _d	4.19	--
T _j =+7°C	P _{dh}	7.62	kW		T _j =+7°C	COP _d	4.98	--
T _j =+12°C	P _{dh}	4.65	kW		T _j =+12°C	COP _d	7.31	--
T _{biv} =bivalent temperature	P _{dh}	22.01	kW		T _{biv} =bivalent temperature	COP _d	2.52	--
T _{oL} =operation temperature	P _{dh}	22.01	kW		T _{oL} =operation temperature	COP _d	2.52	--
Bivalent temperature	T _{biv}	-10	°C					
Degradation co-efficient for heat pumps(**)	C _{dh}	0.25	--					
Power consumption in modes other than "active mode"					Supplementary heater			
Off mode	P _{OFF}	0.005	kW		Back-up heating capacity(*)	e _{lbu}	0.04	kW
Thermosat-off mode	P _{TO}	0.005	kW		Type of energy input			
Crankcase heater mode	P _{CK}	0.04	kW		Standby mode	P _{SB}	0.005	kW
Other items								
Capacity control	variable				For air-to-air heat pump: air flow rate, outdoor measured	--	12500	m ³ /h
Sound power level,outdoor	L _{WA}	82	dB					
GWP of the refrigerant		2088	kg CO ₂ eq (100years)					
Contact details								
(*)								
(**)If C _{dh} is not determined by measurement, then the default degradation coefficient of heat pumps shall be 0.25.								
Where information relates to multi-split heat pumps, xthe test result and performance data may be obtained on the basis of performance of the outdoor unit, with a combination of indoor unit(s) recommended by the manufacturer or importer.								

16HP

Cooling mode:

Information requirements for air-to-air conditioners							
Model(s): MV8S-450WV2RN1							
Test matching indoor units form, cassette: MIH56Q4N18 + 4×MIH80Q4N18 + MIH90Q4N18							
Outdoor side heat exchanger of air conditioner: air							
Indoor side heat exchanger of air conditioner: air							
Type: compressor driven							
Driver of compressor: electric motor							
Item	Symbol	Value	Unit	Item	Symbol	Value	Unit
Rated cooling capacity	$P_{rated,c}$	45.00	kW	Seasonal space cooling energy efficiency	$\eta_{s,c}$	267.8	%
Declared cooling capacity for part load at given outdoor temperatures T_j and indoor 27/19°C (dry/wet bulb)				Declared energy efficiency ratio or gas utilisation efficiency /auxiliary energy factor for part load at given outdoor temperatures T_j			
$T_j=+35^\circ\text{C}$	P_{dc}	45.00	kW	$T_j=+35^\circ\text{C}$	EER_d	2.82	--
$T_j=+30^\circ\text{C}$	P_{dc}	33.17	kW	$T_j=+30^\circ\text{C}$	EER_d	4.47	--
$T_j=+25^\circ\text{C}$	P_{dc}	21.31	kW	$T_j=+25^\circ\text{C}$	EER_d	7.91	--
$T_j=+20^\circ\text{C}$	P_{dc}	9.46	kW	$T_j=+20^\circ\text{C}$	EER_d	14.20	--
Degradation co-efficient for air conditioners(*)							
	C_{dc}	0.25	--				
Power consumption in modes other than "active mode"							
Off mode	P_{OFF}	0.005	kW	Crankcase heater mode	P_{CK}	0.04	kW
Thermosat-off mode	P_{TO}	0.005	kW	Standby mode	P_{SB}	0.005	kW
Other items							
Capacity control	variable			For air-to-air air conditioner: air flow rate, outdoor measured	--	18500	m ³ /h
Sound power level, outdoor	L_{WA}	86	dB				
GWP of the refrigerant		2088	kg CO ₂ eq (100years)				
Contact details							
(*)If C_{dc} is not determined by measurement, then the default degradation coefficient of heat pumps shall be 0.25.							
Where information relates to multi-split air conditioners, the test result and performance data may be obtained on the basis of performance of the outdoor unit, with a combination of indoor unit(s) recommended by the manufacturer or importer.							

16HP

Heating mode:

Information requirements for heat pumps								
Model(s): MV8S-450WV2RN1								
Test matching indoor units form, cassette: MIH56Q4N18 + 4×MIH80Q4N18 + MIH90Q4N18								
Outdoor side heat exchanger of air conditioner: air								
Indoor side heat exchanger of air conditioner: air								
If the heater is equipped with a supplementary heater: no								
Driver of compressor: electric motor								
Parameters shall be declared for the average heating season, parameters for the warmer and colder heating seasons are optional.								
Item	Symbol	Value	Unit		Item	Symbol	Value	Unit
Rated heating capacity	P _{rated,h}	45.00	kW		Seasonal space heating energy efficiency	η _{s,h}	166.2	%
Declared heating capacity for part load at indoor temperature 20°C and outdoor temperatures T _j					Declared coefficient of performance or gas utilisation efficiency/auxiliary energy factor for part load at given outdoor temperatures T _j			
T _j =-7°C	P _{dh}	21.88	kW		T _j =-7°C	COP _d	2.68	--
T _j =+2°C	P _{dh}	13.32	kW		T _j =+2°C	COP _d	4.29	--
T _j =+7°C	P _{dh}	8.57	kW		T _j =+7°C	COP _d	5.13	--
T _j =+12°C	P _{dh}	7.39	kW		T _j =+12°C	COP _d	6.96	--
T _{biv} =bivalent temperature	P _{dh}	24.74	kW		T _{biv} =bivalent temperature	COP _d	2.08	--
T _{OL} =operation temperature	P _{dh}	24.74	kW		T _{OL} =operation temperature	COP _d	2.08	--
Bivalent temperature	T _{biv}	-10	°C					
Degradation co-efficient for heat pumps(**)								
	C _{dh}	0.25	--		Supplementary heater			
Power consumption in modes other than "active mode"					Back-up heating capacity(*)			
Off mode	P _{OFF}	0.005	kW		elbu	0.04	kW	
Thermosat-off mode	P _{TO}	0.005	kW		Type of energy input			
Crankcase heater mode	P _{CK}	0.04	kW		Standby mode	P _{SB}	0.005	kW
Other items								
Capacity control	variable				For air-to-air heat pump: air flow rate, outdoor measured	--	18500	m ³ /h
Sound power level,outdoor	LWA	86	dB					
GWP of the refrigerant		2088	kg CO ₂ eq (100years)					
Contact details								
(*)								
(**)If C _{dh} is not determined by measurement, then the default degradation coefficient of heat pumps shall be 0.25.								
Where information relates to multi-split heat pumps, xthe test result and performance data may be obtained on the basis of performance of the outdoor unit, with a combination of indoor unit(s) recommended by the manufacturer or importer.								

18HP

Cooling mode:

Information requirements for air-to-air conditioners								
Model(s): MV8S-500WV2RN1								
Test matching indoor units form, cassette: 4×MIH45Q4N18 + 4×MIH80Q4N18								
Outdoor side heat exchanger of air conditioner: air								
Indoor side heat exchanger of air conditioner: air								
Type: compressor driven								
Driver of compressor: electric motor								
Item	Symbol	Value	Unit		Item	Symbol	Value	Unit
Rated cooling capacity	$P_{rated,c}$	50.00	kW		Seasonal space cooling energy efficiency	$\eta_{s,c}$	255.8	%
Declared cooling capacity for part load at given outdoor temperatures T_j and indoor 27/19°C (dry/wet bulb)					Declared energy efficiency ratio or gas utilisation efficiency /auxiliary energy factor for part load at given outdoor temperatures T_j			
$T_j=+35^\circ\text{C}$	P_{dc}	50.00	kW		$T_j=+35^\circ\text{C}$	EER _d	2.57	--
$T_j=+30^\circ\text{C}$	P_{dc}	37.12	kW		$T_j=+30^\circ\text{C}$	EER _d	4.19	--
$T_j=+25^\circ\text{C}$	P_{dc}	23.89	kW		$T_j=+25^\circ\text{C}$	EER _d	7.78	--
$T_j=+20^\circ\text{C}$	P_{dc}	10.61	kW		$T_j=+20^\circ\text{C}$	EER _d	13.80	--
Degradation co-efficient for air conditioners(*)								
	C_{dc}	0.25	--					
Power consumption in modes other than "active mode"								
Off mode	P_{OFF}	0.005	kW		Crankcase heater mode	P_{CK}	0.04	kW
Thermosat-off mode	P_{TO}	0.005	kW		Standby mode	P_{SB}	0.005	kW
Other items								
Capacity control	variable				For air-to-air air conditioner: air flow rate, outdoor measured	--	20000	m ³ /h
Sound power level, outdoor	L_{WA}	88	dB					
GWP of the refrigerant		2088	kg CO ₂ eq (100years)					
Contact details								
(*)If C_{dc} is not determined by measurement, then the default degradation coefficient of heat pumps shall be 0.25.								
Where information relates to multi-split air conditioners, the test result and performance data may be obtained on the basis of performance of the outdoor unit, with a combination of indoor unit(s) recommended by the manufacturer or importer.								

18HP

Heating mode:

Information requirements for heat pumps							
Model(s): MV8S-500WV2RN1							
Test matching indoor units form, cassette: 4×MIH45Q4N18 + 4×MIH80Q4N18							
Outdoor side heat exchanger of air conditioner: air							
Indoor side heat exchanger of air conditioner: air							
If the heater is equipped with a supplementary heater: no							
Driver of compressor: electric motor							
Parameters shall be declared for the average heating season, parameters for the warmer and colder heating seasons are optional.							
Item	Symbol	Value	Unit	Item	Symbol	Value	Unit
Rated heating capacity	$P_{rated,h}$	50.00	kW	Seasonal space heating energy efficiency	$\eta_{s,h}$	163.8	%
Declared heating capacity for part load at indoor temperature 20°C and outdoor temperatures T_j				Declared coefficient of performance or gas utilisation efficiency/auxiliary energy factor for part load at given outdoor temperatures T_j			
$T_j=-7^\circ\text{C}$	P_{dh}	26.43	kW	$T_j=-7^\circ\text{C}$	COP_d	2.62	--
$T_j=+2^\circ\text{C}$	P_{dh}	16.46	kW	$T_j=+2^\circ\text{C}$	COP_d	4.23	--
$T_j=+7^\circ\text{C}$	P_{dh}	9.51	kW	$T_j=+7^\circ\text{C}$	COP_d	5.53	--
$T_j=+12^\circ\text{C}$	P_{dh}	7.50	kW	$T_j=+12^\circ\text{C}$	COP_d	6.12	--
T_{biv} =bivalent temperature	P_{dh}	27.50	kW	T_{biv} =bivalent temperature	COP_d	2.13	--
T_{oL} =operation temperature	P_{dh}	27.50	kW	T_{oL} =operation temperature	COP_d	2.13	--
Bivalent temperature	T_{biv}	-10	°C				
Degradation co-efficient for heat pumps(**)							
	C_{dh}	0.25	--	Supplementary heater			
Power consumption in modes other than "active mode"				Supplementary heater			
Off mode	P_{OFF}	0.005	kW	Back-up heating capacity(*)	e_{bu}	0.04	kW
Thermosat-off mode	P_{TO}	0.005	kW	Type of energy input			
Crankcase heater mode	P_{CK}	0.04	kW	Standby mode	P_{SB}	0.005	kW
Other items							
Capacity control	variable			For air-to-air heat pump: air flow rate, outdoor measured	--	20000	m ³ /h
Sound power level,outdoor	LWA	88	dB				
GWP of the refrigerant		2088	kg CO ₂ eq (100years)				
Contact details							
(*)							
(**)If C_{dh} is not determined by measurement, then the default degradation coefficient of heat pumps shall be 0.25.							
Where information relates to multi-split heat pumps, xthe test result and performance data may be obtained on the basis of performance of the outdoor unit, with a combination of indoor unit(s) recommended by the manufacturer or importer.							

20HP

Cooling mode:

Information requirements for air-to-air conditioners							
Model(s): MV8S-560WV2RN1							
Test matching indoor units form, cassette: 2×MIH45Q4N18 + 6×MIH80Q4N18							
Outdoor side heat exchanger of air conditioner: air							
Indoor side heat exchanger of air conditioner: air							
Type: compressor driven							
Driver of compressor: electric motor							
Item	Symbol	Value	Unit	Item	Symbol	Value	Unit
Rated cooling capacity	$P_{rated,c}$	56.00	kW	Seasonal space cooling energy efficiency	$\eta_{s,c}$	249.0	%
Declared cooling capacity for part load at given outdoor temperatures T_j and indoor 27/19°C (dry/wet bulb)				Declared energy efficiency ratio or gas utilisation efficiency /auxiliary energy factor for part load at given outdoor temperatures T_j			
$T_j=+35^\circ\text{C}$	P_{dc}	56.00	kW	$T_j=+35^\circ\text{C}$	EER _d	2.45	--
$T_j=+30^\circ\text{C}$	P_{dc}	40.04	kW	$T_j=+30^\circ\text{C}$	EER _d	4.10	--
$T_j=+25^\circ\text{C}$	P_{dc}	25.74	kW	$T_j=+25^\circ\text{C}$	EER _d	7.64	--
$T_j=+20^\circ\text{C}$	P_{dc}	12.26	kW	$T_j=+20^\circ\text{C}$	EER _d	13.60	--
Degradation co-efficient for air conditioners(*)							
	C_{dc}		--				
Power consumption in modes other than "active mode"							
Off mode	P_{OFF}	0.005	kW	Crankcase heater mode	P_{CK}	0.04	kW
Thermosat-off mode	P_{TO}	0.005	kW	Standby mode	P_{SB}	0.005	kW
Other items							
Capacity control	variable			For air-to-air air conditioner: air flow rate, outdoor measured	--	18500	m ³ /h
Sound power level, outdoor	L_{WA}	89	dB				
GWP of the refrigerant		2088	kg CO ₂ eq (100years)				
Contact details							
(*)If C_{dc} is not determined by measurement, then the default degradation coefficient of heat pumps shall be 0.25.							
Where information relates to multi-split air conditioners, the test result and performance data may be obtained on the basis of performance of the outdoor unit, with a combination of indoor unit(s) recommended by the manufacturer or importer.							

20HP

Heating mode:

Information requirements for heat pumps								
Model(s): MV8S-560WV2RN1								
Test matching indoor units form, cassette: 2×MIH45Q4N18 + 6×MIH80Q4N18								
Outdoor side heat exchanger of air conditioner: air								
Indoor side heat exchanger of air conditioner: air								
If the heater is equipped with a supplementary heater: no								
Driver of compressor: electric motor								
Parameters shall be declared for the average heating season, parameters for the warmer and colder heating seasons are optional.								
Item	Symbol	Value	Unit		Item	Symbol	Value	Unit
Rated heating capacity	P _{rated,h}	56.00	kW		Seasonal space heating energy efficiency	η _{s,h}	159.8	%
Declared heating capacity for part load at indoor temperature 20°C and outdoor temperatures T _j					Declared coefficient of performance or gas utilisation efficiency/auxiliary energy factor for part load at given outdoor temperatures T _j			
T _j =-7°C	P _{dh}	30.51	kW		T _j =-7°C	COP _d	2.57	--
T _j =+2°C	P _{dh}	18.58	kW		T _j =+2°C	COP _d	3.59	--
T _j =+7°C	P _{dh}	12.42	kW		T _j =+7°C	COP _d	6.36	--
T _j =+12°C	P _{dh}	10.38	kW		T _j =+12°C	COP _d	8.31	--
T _{biv} =bivalent temperature	P _{dh}	34.52	kW		T _{biv} =bivalent temperature	COP _d	2.03	--
T _{oL} =operation temperature	P _{dh}	34.52	kW		T _{oL} =operation temperature	COP _d	2.03	--
Bivalent temperature	T _{biv}	-10	°C					
Degradation co-efficient for heat pumps(**)								
	C _{dh}	0.25	--		Supplementary heater			
Power consumption in modes other than "active mode"					Back-up heating capacity(*)			
Off mode	P _{OFF}	0.005	kW		elbu	0.04	kW	
Thermosat-off mode	P _{TO}	0.005	kW		Type of energy input			
Crankcase heater mode	P _{CK}	0.04	kW		Standby mode	P _{SB}	0.005	kW
Other items								
Capacity control	variable				For air-to-air heat pump: air flow rate, outdoor measured	--	18500	m ³ /h
Sound power level,outdoor	LWA	89	dB					
GWP of the refrigerant		2088	kg CO ₂ eq (100years)					
Contact details								
(*)								
(**)If C _{dh} is not determined by measurement, then the default degradation coefficient of heat pumps shall be 0.25.								
Where information relates to multi-split heat pumps, xthe test result and performance data may be obtained on the basis of performance of the outdoor unit, with a combination of indoor unit(s) recommended by the manufacturer or importer.								

22HP

Cooling mode:

Information requirements for air-to-air conditioners							
Model(s):MV8S-615WV2RN1							
Test matching indoor units form, cassette: 8×MIH80Q4N18							
Outdoor side heat exchanger of air conditioner: air							
Indoor side heat exchanger of air conditioner: air							
Type: compressor driven							
Driver of compressor: electric motor							
Item	Symbol	Value	Unit	Item	Symbol	Value	Unit
Rated cooling capacity	$P_{rated,c}$	61.50	kW	Seasonal space cooling energy efficiency	$\eta_{s,c}$	243.0	%
Declared cooling capacity for part load at given outdoor temperatures T_j and indoor 27/19°C (dry/wet bulb)				Declared energy efficiency ratio or gas utilisation efficiency /auxiliary energy factor for part load at given outdoor temperatures T_j			
$T_j=+35^\circ\text{C}$	P_{dc}	61.50	kW	$T_j=+35^\circ\text{C}$	EER_d	2.00	--
$T_j=+30^\circ\text{C}$	P_{dc}	43.96	kW	$T_j=+30^\circ\text{C}$	EER_d	4.24	--
$T_j=+25^\circ\text{C}$	P_{dc}	28.27	kW	$T_j=+25^\circ\text{C}$	EER_d	7.60	--
$T_j=+20^\circ\text{C}$	P_{dc}	12.57	kW	$T_j=+20^\circ\text{C}$	EER_d	13.13	--
Degradation co-efficient for air conditioners(*)							
	C_{dc}	0.25	--				
Power consumption in modes other than "active mode"							
Off mode	P_{OFF}	0.005	kW	Crankcase heater mode	P_{CK}	0.04	kW
Thermosat-off mode	P_{TO}	0.005	kW	Standby mode	P_{SB}	0.005	kW
Other items							
Capacity control	variable			For air-to-air air conditioner: air flow rate, outdoor measured	--	19000	m ³ /h
Sound power level, outdoor	L_{WA}	89	dB				
GWP of the refrigerant		2088	kg CO ₂ eq (100years)				
Contact details							
(*)If C_{dc} is not determined by measurement, then the default degradation coefficient of heat pumps shall be 0.25.							
Where information relates to multi-split air conditioners, the test result and performance data may be obtained on the basis of performance of the outdoor unit, with a combination of indoor unit(s) recommended by the manufacturer or importer.							

22HP

Heating mode:

Information requirements for heat pumps								
Model(s):MV8S-615WV2RN1								
Test matching indoor units form, cassette: 8×MIH80Q4N18								
Outdoor side heat exchanger of air conditioner: air								
Indoor side heat exchanger of air conditioner: air								
If the heater is equipped with a supplementary heater: no								
Driver of compressor: electric motor								
Parameters shall be declared for the average heating season, parameters for the warmer and colder heating seasons are optional.								
Item	Symbol	Value	Unit		Item	Symbol	Value	Unit
Rated heating capacity	$P_{rated,h}$	61.50	kW		Seasonal space heating energy efficiency	$\eta_{s,h}$	157.0	%
Declared heating capacity for part load at indoor temperature 20°C and outdoor temperatures T_j					Declared coefficient of performance or gas utilisation efficiency/auxiliary energy factor for part load at given outdoor temperatures T_j			
$T_j=-7^\circ\text{C}$	P_{dh}	32.36	kW		$T_j=-7^\circ\text{C}$	COP_d	2.55	--
$T_j=+2^\circ\text{C}$	P_{dh}	19.70	kW		$T_j=+2^\circ\text{C}$	COP_d	3.46	--
$T_j=+7^\circ\text{C}$	P_{dh}	12.67	kW		$T_j=+7^\circ\text{C}$	COP_d	6.31	--
$T_j=+12^\circ\text{C}$	P_{dh}	10.84	kW		$T_j=+12^\circ\text{C}$	COP_d	8.99	--
T_{biv} =bivalent temperature	P_{dh}	36.60	kW		T_{biv} =bivalent temperature	COP_d	2.04	--
T_{OL} =operation temperature	P_{dh}	36.60	kW		T_{OL} =operation temperature	COP_d	2.04	--
Bivalent temperature	T_{biv}	-10	°C					
Degradation co-efficient for heat pumps(**)								
	C_{dh}	0.25	--		Supplementary heater			
Power consumption in modes other than "active mode"					Back-up heating capacity(*)			
Off mode	P_{OFF}	0.005	kW		e_{lbu}	0.04	kW	
Thermosat-off mode	P_{TO}	0.005	kW		Type of energy input			
Crankcase heater mode	P_{CK}	0.04	kW		Standby mode	P_{SB}	0.005	kW
Other items								
Capacity control	variable				For air-to-air heat pump: air flow rate, outdoor measured	--	19000	m ³ /h
Sound power level,outdoor	LWA	89	dB					
GWP of the refrigerant		2088	kg CO ₂ eq (100years)					
Contact details								
(*)								
(**)If C_{dh} is not determined by measurement, then the default degradation coefficient of heat pumps shall be 0.25.								
Where information relates to multi-split heat pumps, xthe test result and performance data may be obtained on the basis of performance of the outdoor unit, with a combination of indoor unit(s) recommended by the manufacturer or importer.								

16127000004688 V.F



Multi-languages

印刷技术要求

材质	封面, 封底: 105克铜版纸, 内页: 80g双胶纸
规格	210*297(双面)
颜色	黑白
其他	/

设计更改记录表 (仅做说明用, 不做菲林)

版本升级	更改人	更改日期	更改主要内容	涉及更改页面 (印刷页码)
B-C	黄业祥	20221120	1、增加小语种二维码; 2、更新U21故障代码含义 3、新增d42故障代码; 4、内容勘误 5、封底图号升级	多处
C-D	敖俊	2023-1-15	1、附件管尺寸描述勘误 2、图号升级	P13/封底
D-E	黄业祥	2023-7-3	1、按可靠性标准化项目PS00023D92要求, 对通用性描述进行质量提升; 2、新增FL1故障, 补充L类和J类故障代码; 3、调试流程增加试运转 4、更新系统原理图风格, 和MDT的风格保持一致; 5、更正TOCA电流参数; 6、图号升级	多处
E-F	陈家金	2026-1-29	1、P7, F6A故障描述修改; 2、P9, 1L01故障描述修改; 3、P8, xP33故障描述 4、图号升级	P7,P8,P9/封底

