

INSTALLATION INSTRUCTIONS

APARTMENT FAN COIL UNIT

MHVE MHVP

NOTE: Read the entire instruction manual before starting installation.

These instructions must be read and understood completely before attempting installation.

TABLE OF CONTENTS

	PAGE
SAFETY CONSIDERATIONS	1
INTRODUCTION	1
INSTALLATION	2
Step 1 — Check Equipment	2
Step 2 — Mount Fan Coil	2
Step 3 — Ductwork Specifications	4
Step 4 — Condensate Drain	4
Step 5 — Electrical Connections	4
Step 6 — Select Proper Blower Speed	5
Step 7 — TXV	6
START-UP	6
SEQUENCE OF OPERATION	6
CARE AND MAINTENANCE	6
AIRFLOW PERFORMANCE TABLES	7

SAFETY CONSIDERATIONS

Improper installation, adjustment, alteration, service, maintenance, or use can cause explosion, fire, electrical shock, or other conditions which may cause death, personal injury or property damage. Consult a qualified installer, service agency, or your distributor or branch for information or assistance. The qualified installer or agency must use factory authorized kits or accessories when modifying this product. Refer to individual instructions packaged with kits or accessories when installing.

Follow all safety codes. Wear safety glasses, protective clothing, and work gloves. Use quenching cloth for brazing operations. Have a fire extinguisher available. Read these instructions thoroughly and follow all warning or cautions included in literature and attached to the unit. Consult local building codes and the current editions of the National Electrical Code (NEC) NFPA 70.

In Canada, refer to the current editions of Canadian Electrical Code CSA C22.1.

Recognize safety information. This is the safety alert symbol . When you see this symbol on the unit and in instructions or manuals, be alert to the potential for personal injury. Understand the signal words **DANGER**, **WARNING**, and **CAUTION**. These words are used with the safety alert symbol. **DANGER** identifies the most serious hazards which **will** result in severe personal injury or death. **WARNING** signifies hazards which **could** result in personal injury or death. **CAUTION** is used to identify unsafe practices, which **may** result in minor personal injury or product and property

damage. **NOTE** is used to highlight suggestions which **will** result in enhanced installation, reliability, or operation.

INTRODUCTION

MHVE, MHVP Fan Coils are designed with application flexibility in mind and are suitable for closet and flush mount installations. Units are available with field-installed electric heat with circuit breaker. Units are used indoors as the fan coil for split-system heat pumps or air conditioners. The MHVP uses a refrigerant piston metering device and a 3 Speed PSC Motor. MHVE uses a TXV and a 5 speed multi-tap ECM motor for efficiency. Units are available in 18,000 through 36,000 Btuh nominal cooling capacities.

Field-installed heaters are available in 5, 7.5, and 10 kW sizes. The coil is equipped with sweat-type connections and is vapor-charged with dry nitrogen. This unit is approved for installation in conditioned spaces only.

NOTE: Nuisance sweating may occur if the unit is installed in a humid location with low airflow.

Units are designed for upflow applications only. Local codes may limit this free-air-return type unit to installation in single-level applications.

 **WARNING**

ELECTRICAL OPERATION HAZARD
 Failure to follow this warning could result in personal injury or death.
 Before installing or servicing unit, always turn off all power to unit. There may be more than 1 disconnect switch. Turn off accessory heater power if applicable. Lock out and tag switch with a suitable warning label.

 **WARNING**



EXPLOSION HAZARD
 Failure to follow this warning could result in death, serious personal injury, and/or property damage.
 Never use air or gases containing oxygen for leak testing or operating refrigerant compressors. Pressurized mixtures of air or gases containing oxygen can lead to an explosion.

 **CAUTION**

CUT HAZARD
 Failure to follow this caution may result in personal injury.
 Sheet metal parts may have sharp edges or burrs. Use care and wear appropriate protective clothing and gloves when handling parts.

Figure 1 - Dimensional Drawing with Circuit Breaker

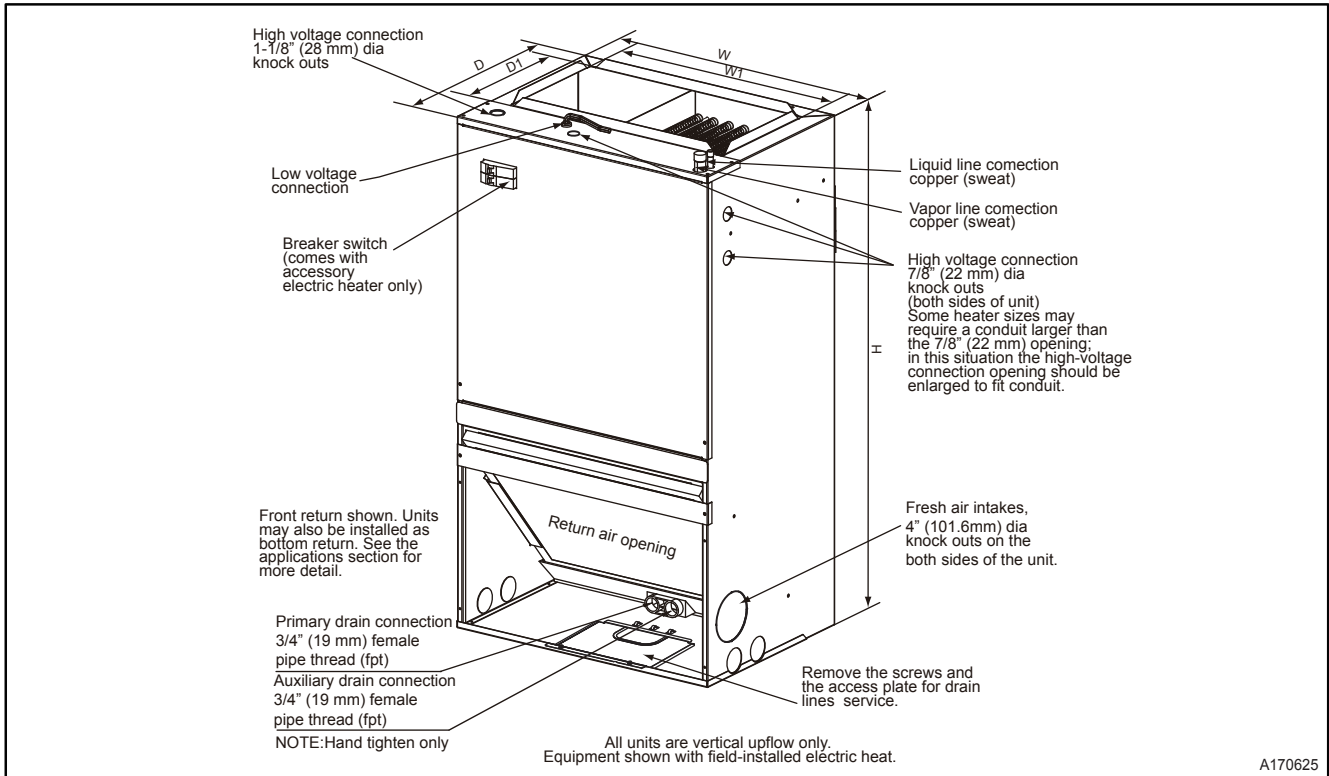

Table 1 – Dimensional Data

Model Size	Dimensions-In. (mm)					Unit Weight / Shipping Weight Lbs. (kg)
	Unit Height H	Unit Width W	Unit Width W1	Unit Depth D	Unit Depth D1	
PSC 18K/24K	36-1/2 (928)	20-1/2 (521)	17-2/5 (442)	15 (381)	9-1/2 (242)	88 / 101 (40 / 46)
PSC 30K/36K	39-1/2 (1004)	22 (559)	18-4/5 (478)	19 (483)	9-1/2 (242)	106 / 123 (48 / 56)
ECM 18K/24K	36-1/2 (928)	20-1/2 (521)	17-2/5 (442)	15 (381)	9-1/2 (242)	79/ 95 (36 / 43)
ECM 30K/36K	39-1/2 (1004)	22 (559)	18-4/5 (478)	19 (483)	9-1/2 (242)	97/ 119 (44 / 54)

INSTALLATION

Step 1 — Check Equipment

Unpack unit and move to final location. Remove carton, taking care not to damage unit. Remove protective sheet metal from the base of the unit, if equipped. Inspect equipment for damage prior to installation. File claim with shipping company if shipment is damaged or incomplete. Locate rating plate on unit. It contains information needed to properly install unit. Check rating plate to be sure unit matches job specifications. A front access panel is provided, which permits access to blower assembly and electrical controls for removal and servicing.

NOTE: Minimum clearance of 21" (533 mm) is required in front of access panel for servicing only. Installation clearance from combustible materials is 0" (0 mm) from cabinet and supply air duct (plenum included). Ensure there is adequate space on top of unit for refrigerant line connections and on bottom of unit for condensate trap. (See **Figure 1** and **Figure 2**.)

Step 2 — Mount Fan Coil

Fan Coil Mounting Options

The fan coil comes standard with two different options for mounting: wall mount or frame mount. Both mounting options require the unit to be level from side to side and from front to

back in order to allow condensate to properly drain from the unit. Failure to do this will result in condensate leaking out from the unit, potentially causing structural damage to the surrounding support structures, drywall, carpet, etc. around the unit. Also, both mounting structures require the ability to accommodate a minimum of load of 150 pounds. Failure to do this will cause damage to the support structure and potentially damage the unit.

Figure 2 - Condensate Drain

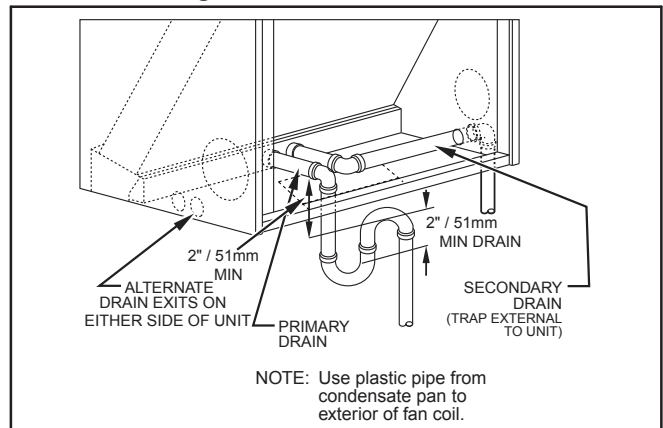
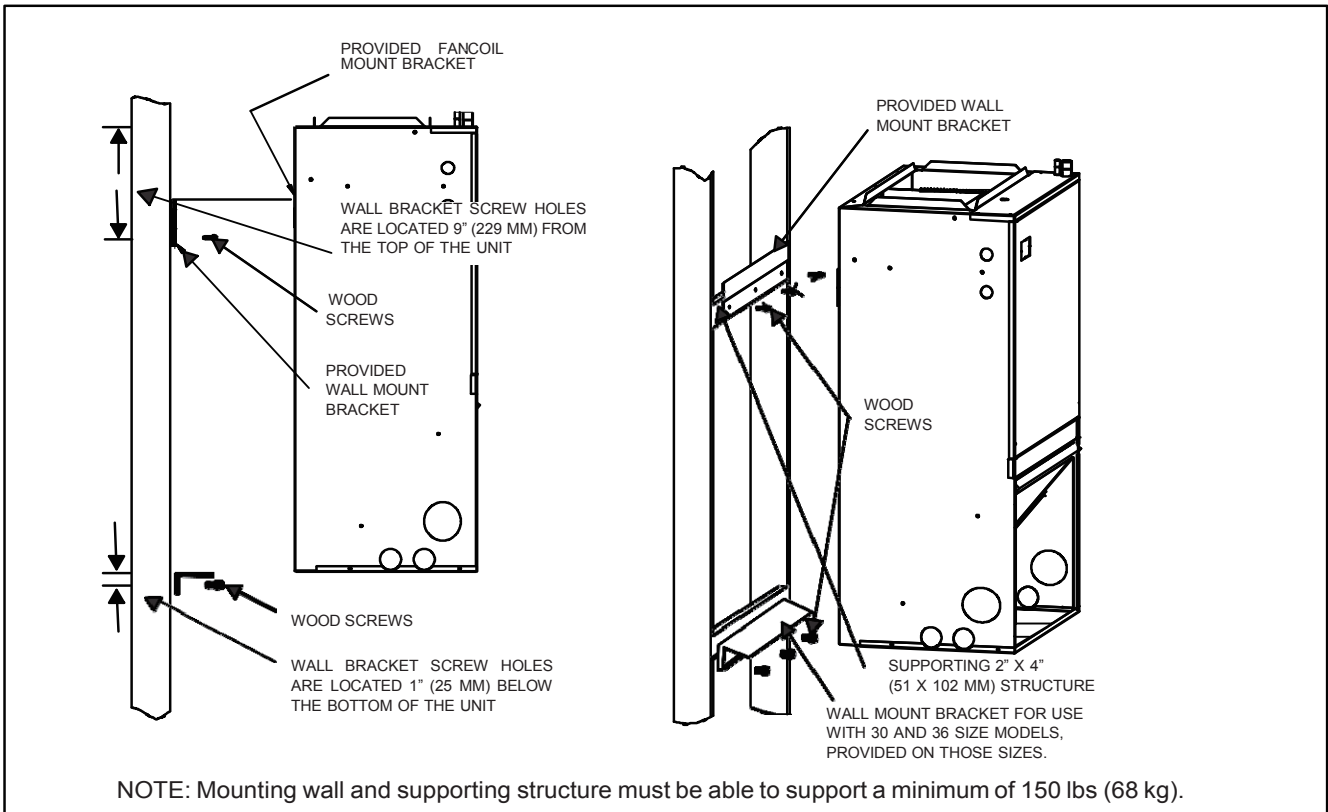

Figure 3 - Wall Mount Installation



NOTE: Mounting wall and supporting structure must be able to support a minimum of 150 lbs (68 kg).

L14S011

Wall Mount

The fan coil comes standard with a wall mounting bracket and fan coil mounting bracket. Reference **Figure 3** for more detail.

1. Remove the wall mounting bracket from the back of the unit by removing one screw which attaches the bracket to the fan coil.

NOTE: Discard the screw after you have removed the wall mounting bracket.

2. Install bracket on the wall by using three wood screws (not provided) per wall-mount bracket. Make sure the bracket is level in order to provide proper drainage from the unit.

NOTE: Do not attach the wall mounting bracket into unsupported drywall. Make sure that the wood screws are going into a structure that can support a minimum load of 150 pounds.

3. Lift the fan coil above the wall mounting bracket and attach the unit to the installed bracket. Reference **Figure 3**.

Frame Mount

The fan coil comes with eight clearance holes, four on each side. These holes are used to mount the fan coil inside a frame structure (see **Figure 4**). When mounting in this fashion, make sure that the wood screws are mounted from within the fan coil and not outside of the unit. Installing the screws from outside of the unit may damage the coil.

After moving unit into place, install refrigerant tubing as follows:

1. Route tubing to connection points, taking care not to block service access.
2. Remove plugs from liquid and vapor lines.
3. Braze connections using either silver bearing or non-silver bearing brazing material. Do not use soft solder (materials which melt below 800°F / 427°C).

through the system refrigerant lines while brazing.

4. Pressurize system and leak-test. Repeat procedure until leak-free.

NOTE: MHVP are shipped with a piston metering device designed for the most common outdoor unit matches. Refer to AHRI ratings to check if your combination can use the piston shipped with the unit or requires an accessory TXV. MHVE are provided with a factory installed TXV.

Figure 4 - Frame Mount Installation

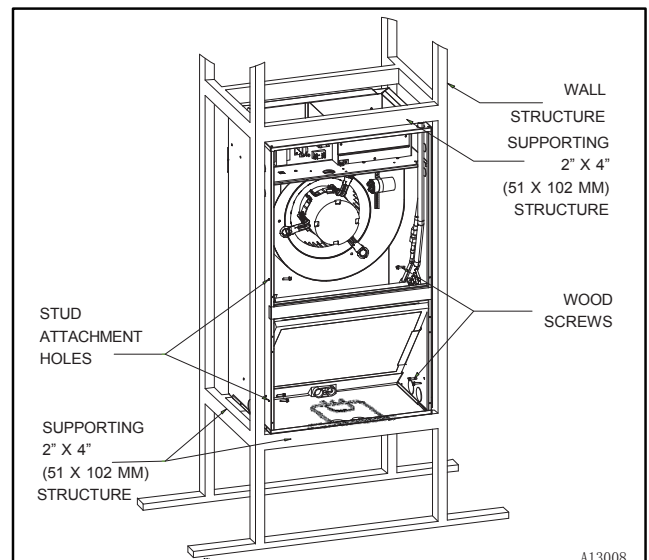

A13008

⚠ CAUTION

ENVIRONMENTAL HAZARD

Failure to follow this caution may result in environmental damage.

Do not vent refrigerant to atmosphere. Recover during system repair or final unit disposal.

Step 3 — Ductwork Specifications

Connect supply- air duct over 3/4" (19 mm) flange provided on supply- air opening. Secure duct to flange using applicable fasteners for type of duct used, and seal duct-to-unit joint.

NOTE: Short duct runs tend to increase noise level.

When fan coil is equipped with an electric heater, install air ducts in accordance with standards 90A and 90B of National Fire Protection Association (NFPA). Use of flexible connectors between ductwork and unit will prevent transmission of vibration. When electric heater is installed, use heat-resistant material for a flexible connector between ductwork and unit air discharge connection. Ductwork passing through unconditioned space must be insulated and covered with a vapor barrier.

NOTE: Unit is intended for nonducted return- air applications. Local codes may limit this unit to single-level applications.

⚠ WARNING

INJURY HAZARD

Failure to follow this warning could result in personal injury or death.

Do not, under any circumstances, connect return ductwork to any other heat-producing device such as fireplace inserts, stoves, etc. Unauthorized use of such devices may result in fire, carbon monoxide poisoning, explosion, personal injury or property damage.

Design the duct system in accordance with "ACCA" Manual "0" Design for Residential Winter and Summer Conditioning and Equipment Selection. Latest editions are available from : "ACCA" Air Conditioning Contractors of America. If duct system incorporates flexible air duct, be sure pressure drop information (straight length plus all turns) shown in "ACCA" Manual "D" is accounted for in system.

Conversion to Bottom Return

This product is shipped configured for front return and can be converted for bottom return. To convert the unit to bottom return, remove the bottom panel and lower front panel (short panel above front opening and below the filter slot). Attach the panel removed from the bottom of the unit to the front return opening.

Step 4 — Condensate Drain

Condensate pan has primary and secondary drain connections to meet FHA requirements. (See **Figure 2**) These connections have 3/4" (19 mm) female pipe threads. Tubing for all condensate drains should be a minimum of 7/8" (22 mm) OD. Drain lines from condensate pan to exterior of unit must be plastic pipe. Drain should be pitched downward at a slope of 1" per 10' (25 mm per 3 m). If coil is located in or above a living space where damage may result from condensate overflow, a separate 3/4" (19 mm) drain must be provided from secondary drain connection. Run this drain to a place in compliance with local installation codes where it will be noticed when unit is operational.

Condensate flow from secondary drain indicates a plugged primary drain. Install a 2" (51 mm) trap in condensate drain line as close to coil as possible. A factory approved drain trap kit, is available. Make sure that the top of trap is below connection to drain pan to prevent condensate from overflowing drain pan. Prime all traps, test for leaks, and insulate in areas where sweating of the traps and drain lines could potentially cause water damage Consult local codes for additional restrictions or precautions.

Optional extrusions are provided on bottom panel if installer wishes to secure drain lines. See **Figure 5** for detail. Accessory UV lights are not approved for use with this fan coil.

Figure 5 - Drainline Installation

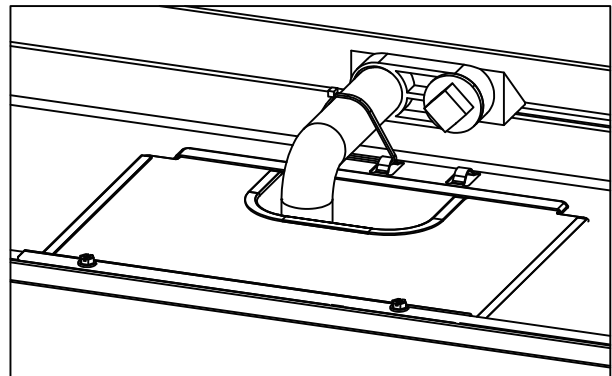

Step 5 — Electrical Connections

⚠ WARNING

ELECTRICAL OPERATION HAZARD

Failure to follow this warning could result in personal injury or death.

Before installing or servicing unit, always turn off all power to unit. There may be more than one disconnect switch. Turn off accessory heater power if applicable. Lock out and tag switch with a suitable warning label.

Refer to unit wiring instructions for recommended wiring procedures. Use No. 18 AWG color-coded, insulated (35°C minimum) wire to make low-voltage connections between thermostat and unit. If thermostat is located more than 100 ft. (30m) from unit as measured along low-voltage wire, use No. 16 AWG color-coded, insulated (35°C minimum) wire.

NOTE: Before proceeding with electrical connections, make certain that voltage, frequency, and phase correspond to that specified on rating plate. Also, check to be sure that the service provided by utility is sufficient to handle additional load imposed by this equipment.

Refer to unit wiring label for proper field high- and low-voltage wiring. Make all electrical connections in accordance with NEC and any local codes or ordinances that might apply. Unit must have a separate branch electrical circuit.

▲ WARNING

ELECTRICAL SHOCK HAZARD

Failure to follow this warning could result in personal injury or death.

Field wires on side of disconnect found in fan coil remain live, even when circuit breaker is off. Service and maintenance to incoming wiring cannot be performed until main disconnect switch (remote to the unit) is turned off. Lock out and tag switch with a suitable warning label.

Unit cabinet must have a continuous electrical path to ground in order to minimize potential for personal injury or death if an electrical fault should occur. This ground may consist of electrical wire or approved conduit when installed in accordance with existing codes. (See Step 3. above.)

NOTE: All units are shipped from factory wired for 240VAC transformer operation. For 208VAC operation, move primary lead from 240VAC terminal to 208VAC terminal.

Figure 6 Transformer Connections

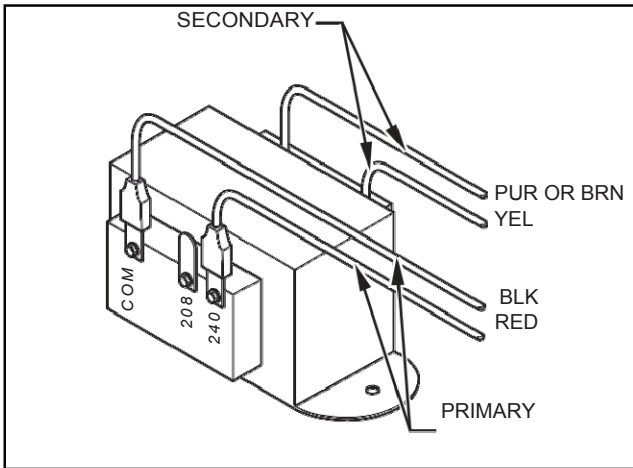

A13092

See **Figure 7** and **Figure 8** for field low-voltage wiring. See **Figure 1** for location of the electrical inlets. For maximum ampacity and over-current protection, see unit rating plate or product data sheet.

1. Provide power supply for unit being installed in accordance with unit wiring diagram and rating plate.
2. Connect line-voltage leads to the harness pigtail or the heat-kit circuit breaker. Use copper wire only.
3. Use UL listed conduit and conduit connector for connecting line-voltage leads to unit and obtaining proper ground. If conduit connection uses reducing washers, a separate ground wire must be used. Grounding can also be accomplished by using the ground lug provided in the control box. Power wiring may be connected to either the right or left sides or top of unit. Knockouts of 7/8" (22 mm) dia. are provided for connection of power wiring to unit. Some heater sizes may require a conduit larger than the 7/8" opening; in this situation the high-voltage connection opening should be enlarged to fit the conduit. When removing the knockouts for electrical connections, an opening in the insulation should be cut

to fit the opening. The cut edge of the insulation should be reinforced with foil tape to prevent fraying. The foil facing and insulation shall not be removed beyond the knockout opening size.

4. Install plastic grommet packed with unit in hole for low-voltage wires.
5. Connect low-voltage leads to thermostat and outdoor unit. See **Figure 7** and **Figure 8** as well as the outdoor unit wiring label.

Figure 7 - Wiring Layout Air Conditioning Unit (Cooling and 1-Stage Heat)

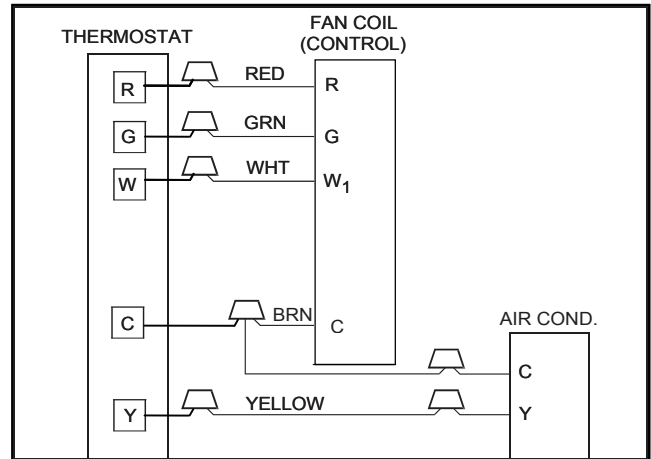

A150158

Figure 8 - Wiring Layout Heat Pump Unit (Cooling and 2-Stage Heat)

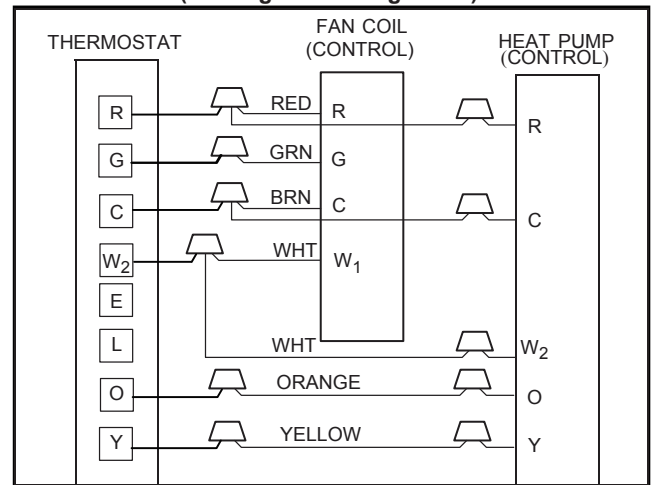

A150159

Step 6 — Select Proper Blower Speed

Before operating unit, be sure that the proper blower speed has been selected. Fan speeds are selected manually.

To change the fan speed on model FMA4P:

Factory default fan speed is **medium**; fan-motor red wire connected to fan relay No. 4 or TDB terminal FAN.

For **high** speed, connect fan-motor black wire to fan relay No. 4 or TDB terminal FAN.

For **low** speed, connect fan-motor blue wire to fan relay No. 4 and fan-motor red wire to fan relay No. 6. Besides, you can also connect fan-motor blue wire to TDB terminal FAN.

Always connect the unused fan-motor wire to the dummy terminal block or TDB terminal M1&M2.

When selecting the proper airflow, refer to **Table 3** below to choose proper blower speeds for cooling and heating.

To change the fan speed on model MHVE:

At the motor connection plug connect the green wire to the desired motor tap number indicated on the motor plug. (See **Figure 9**) For the electric heat fan speed selection connect the white wire to the desired motor tap number indicated on the motor plug. See **Table 2** for factory default settings.

Figure 9 - MHVE ECM Motor Speed Taps

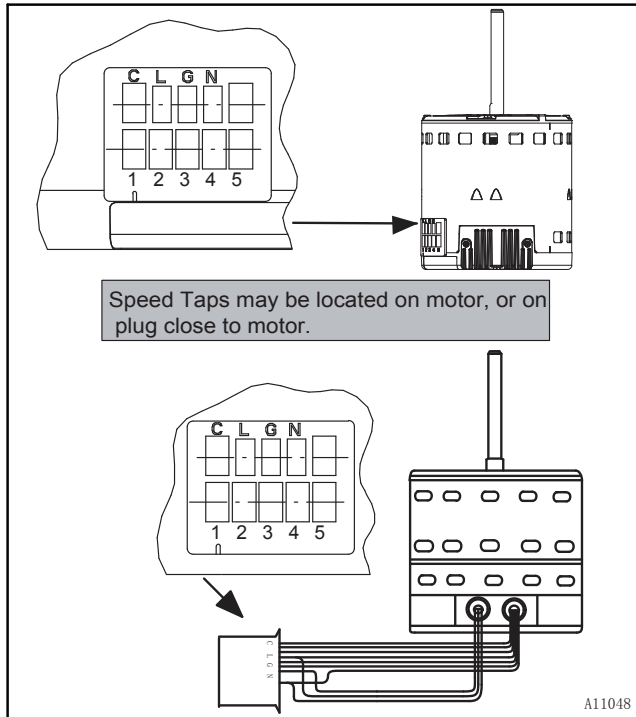

Table 2 – MHVE ECM Motor Speed Taps

Tap	Delay-off Time(s)	18	24	30	36
Tap 1	30	---	---	---	---
Tap 2	90	Default	---	Default	---
Tap 3	30	---	---	---	---
Tap 4	90	---	Default	---	Default
Tap 5	30	---	---	---	---

Figure 10 - Wiring Layout MHVP PSC Motor disable time delay

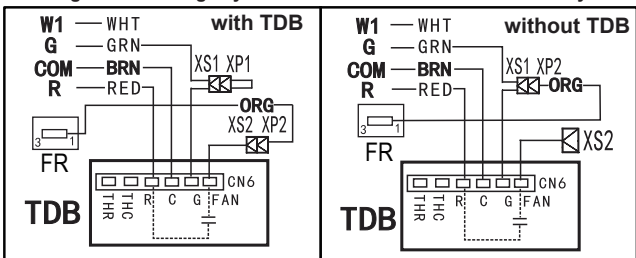
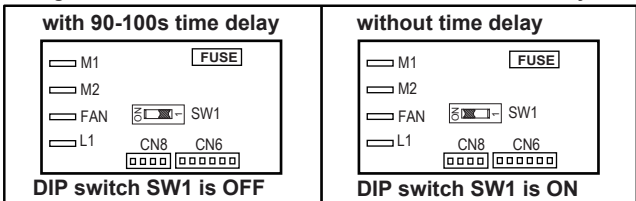

Figure 11 - DIP Switch SW1 MHVP PSC Motor disable time delay



Step 7 — TXV (MHVE Only)

NOTE: The TXVs are preset at the factory and do not need adjustment for reliable operation.

START-UP

Refer to outdoor unit Installation Instructions for system start-up instructions and refrigerant charging method details.

SEQUENCE OF OPERATION

NOTE: The following sequence of operation is based on units installed with PSC motor and Time Delay Board (TDB). For units with ECM motor, the off-delay is programmed into the motor. Follow Table 2, ECM Motor Speed Taps & the corresponding blower off delays for each speed tap. PSC models are factory wired with TDB active. Follow Figure 10 and Figure 11 to disable blower off time delay. When wired in this configuration no blower off-delay will occur in any mode (see Figure 10); When DIP switch SW1 is ON, no blower off-delay will occur in any mode (see Figure 11).

A. CONTINUOUS FAN

Thermostat closes R to G. G energizes and completes circuit to indoor blower motor. When G is de-energized, there is a 90's blower off-delay.

B. COOLING MODE

Thermostat energizes R to G, R to Y, and R to O (heat pump only). G energizes and completes indoor blower motor. Y energizes outdoor unit (O is energized for heat pump). When cooling call is satisfied, G is de-energized, there is a 90s blower off-delay.

C. HEAT PUMP HEATING MODE

Thermostat energizes R to G and R to Y. G energizes and completes circuit to indoor blower motor. When heating call is satisfied, G is de-energized, there is a 90s blower off-delay.

D. HEAT PUMP HEATING WITH AUXILIARY ELECTRIC HEAT

Thermostat energizes R to G, R to Y, and R to W1. G energizes and completes circuit to indoor blower motor. W1 energizes electric heat relay(s) which completes circuit to heater element(s). When W1 is de-energized, electric heat relay(s) open, turning off heater elements. When G is de-energized there is a 90s blower off-delay.

E. ELECTRIC HEAT OR EMERGENCY HEAT MODE

Thermostat energizes R to W1. W1 energizes electric heat relay(s) which completes circuit to heater elements(s). Blower motor is energized through normally closed contacts on fan relay. When W1 is de-energized, electric heat relay(s) opens, there is no blower off-delay, (units with ECM motor will have blower off-delay based on motor speed tap selection).

CARE AND MAINTENANCE

For continuing high performance and to minimize possible equipment failure, it is essential that periodic maintenance be performed on this equipment. The only required maintenance that may be performed by the consumer is filter maintenance.

WARNING

ELECTRICAL OPERATION HAZARD

Failure to follow this warning could result in personal injury or death.

Disconnect all power to unit before servicing field wires or removing control package. The disconnect (when used) on access panel does not allow safe service to all other parts of unit.

If unit does not have a disconnect, disregard the foregoing. Instead, make sure that a disconnecting means is within sight from, and is readily accessible from, the unit.

Disconnect all electrical power to unit before performing any maintenance or service on it. Lock out and tag switch with a suitable warning label.

The minimum maintenance requirements for this equipment are as follows:

1. Inspect and clean or replace air filter each month or as required.
2. Inspect cooling coil, drain pan, and condensate drain each cooling season for cleanliness. Clean as necessary.
3. Inspect blower motor and wheel for cleanliness each heating and cooling season. Clean as necessary.
4. Inspect electrical connections for tightness and controls for proper operation each heating and cooling season. Service as necessary.

NOTE: The installing technician should explain system operation to the consumer with particular emphasis on indoor fan coil operation sounds and filter maintenance.

CAUTION

CUT HAZARD

Failure to follow this caution may result in personal injury.

Sheet metal parts may have sharp edges or burrs. Use care and wear appropriate protective clothing and gloves when handling parts.

Table 3-PSC-Airflow Performance (Standard CFM)

MODEL MHVP	BLOWER SPEEDS	EXTERNAL STATIC PRESSURE (in.w.c.)								
		0	0.1	0.2	0.3	0.4	0.5	0.6	0.7	0.8
18	High	813	775	731	692	653	609	560	501	424
	Med	695	656	620	581	540	498	440	380	-
	Low	603	562	525	485	443	393	-	-	-
24	High	947	895	847	799	753	704	655	592	530
	Med	845	801	759	716	675	626	573	510	-
	Low	676	640	602	563	523	499	-	-	-
30	High	1367	1312	1252	1192	1131	1063	990	908	821
	Med	1211	1165	1114	1065	1016	960	899	833	748
	Low	992	952	912	873	828	782	728	656	627
36	High	1397	1345	1290	1263	1196	1116	1051	980	907
	Med	1298	1252	1198	1147	1094	1037	976	910	842
	Low	1149	1105	1056	1008	960	909	856	791	726

— Shaded boxes represent airflow outside the required 300-450 cfm/ton.

NOTES:

1. Airflow based upon dry coil at 230V with no electric heat and factory--approved filter.
2. Airflow is equivalent for front or bottom return configurations.

Table 4-ECM-Airflow Performance (Standard CFM)

Model	BLOWER SPEEDS	EXTERNAL STATIC PRESSURE(in.w.c.)									
		0	0.1	0.18	0.2	0.3	0.4	0.5	0.6	0.7	0.8
18	Tap(5)	913	881	848	848	818	792	763	731	691	650
	Tap(4)	825	787	756	753	717	682	650	617	580	540
	Tap(3)	737	700	666	663	630	589	550	511	474	436
	Tap(2)-Factory	675	632	598	596	555	521	480	440	399	366
	Tap(1)	590	548	512	499	455	430	368	338	309	263
24	Tap(5)	913	881	848	848	818	792	763	731	691	650
	Tap(4)-Factory	825	787	756	753	717	682	650	617	580	540
	Tap(3)	737	700	666	663	630	589	550	511	474	436
	Tap(2)	675	632	598	596	555	521	480	440	399	366
	Tap(1)	590	548	512	499	455	430	368	338	309	263
30	Tap(5)	1362	1325	1280	1266	1238	1197	1159	1119	1080	1040
	Tap(4)	1282	1242	1195	1176	1151	1111	1071	1028	975	936
	Tap(3)	1267	1225	1178	1143	1120	1078	1036	993	942	897
	Tap(2)-Factory	1157	1111	1061	1052	1016	971	929	884	842	802
	Tap(1)	1077	1028	978	965	932	886	850	804	768	732
36	Tap(5)	1362	1325	1280	1266	1238	1197	1159	1119	1080	1040
	Tap(4)-Factory	1282	1242	1195	1176	1151	1111	1071	1028	975	936
	Tap(3)	1267	1225	1178	1143	1120	1078	1036	993	942	897
	Tap(2)	1157	1111	1061	1052	1016	971	929	884	842	802
	Tap(1)	1077	1028	978	965	932	886	850	804	768	732

— Shaded boxes represent airflow outside the required 300-450 cfm/ton.

NOTES:

1. Airflow based upon dry coil at 230V with no electric heat and factory--approved filter. For MHVE ai at 208V is approximately the same as 230V because the multi-tap ECM motor is a constant torque motor. The torque doesn't drop off at the speeds in which the motor operates.
2. Airflow is equivalent for front or bottom return configurations.

Table 5 – Filter Sizes

Unit Size	Filter Size In. (mm)
18, 24	16x20x1 (406x508x25)
30, 36	20x20x1 (508x508x25)

16123000001234 V.F

本页不出菲林，仅作为电子文档说明

1. 说明书尺寸为大A4
2. 材料：双胶纸80克；
3. 说明书黑白印刷。

V1.1版本修订说明：

在V1.0版本上进行以下修订：

- 1、更新风量为最新；
- 2、更新文件号；
- 3、更改版权为CCS；
- 4、更新修改时间。

V1.2版本修订说明：

- 1、更新风量为最新；
- 2、更改版权为CAC/BDP；
- 3、更新修改时间。

V1.3版本修订说明：

- 1、按照客户要求更改格式和脚注

V1.4版本修订说明

- 1、封面目录排版
- 2、封底页版本号升级
- 3、材质更改为80g

V1.4版本升级为V.F版本修订说明:

1、添加:

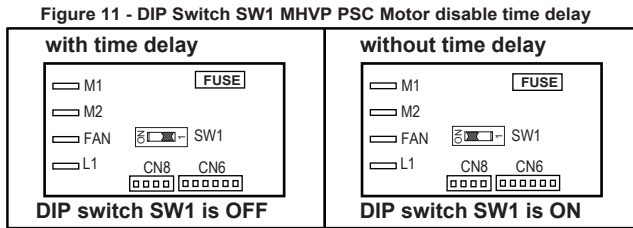

Step 7 — TXV (MHVE Only)

2、

Follow Figure 10 to disable blower off time delay. When wired in this configuration no blower off-delay will occur in any mode 改为

Follow Figure 10 and Figure 11 to disable blower off time delay. When wired in this configuration no blower off-delay will occur in any mode (see Figure 10); When DIP switch SW1 is ON, no blower off-delay will occur in any mode (see Figure 11).

3、第6、7页排版修改

4、第5页变压器次级线体颜色标注BLK改为PUR OR BRN，图7标成了图8，故把 Figure 8 改为Figure 7

WARNING的“See Step 3. below.” 改为 “See Step 3. above.”

5、第5页Step6增加新电控的相关部分内容

To change the fan speed on model FMA4P:

Factory default fan speed is **medium**; fan-motor red wire connected to fan relay No. 4 .

For **high** speed, connect fan-motor black wire to fan relay No. 4.

For **low** speed, connect fan-motor blue wire to fan relay No. 4 and fan-motor red wire to fan relay No. 6.

Always connect the unused fan-motor wire to the dummy terminal block.

改为

To change the fan speed on model FMA4P:

Factory default fan speed is **medium**; fan-motor red wire connected to fan relay No. 4 or TDB terminal FAN.

For **high** speed, connect fan-motor black wire to fan relay No. 4 or TDB terminal FAN.

For **low** speed, connect fan-motor blue wire to fan relay No. 4 and fan-motor red wire to fan relay No. 6. Besides, you can also connect fan-motor blue wire to TDB terminal FAN.

Always connect the unused fan-motor wire to the dummy terminal block or TDB terminal M1&M2.

