

# INSTALLATION MANUAL

## *Split Duct Air Conditioner*

Thank you very much for purchasing our air conditioner,  
Before using your air conditioner, please read this manual carefully and keep it for future reference.



CONTENTS	PAGE
PRECAUTIONS.....	1
ACCESSORIES .....	2
INSTALLATING INDOOR UNIT .....	2
INSTALLATING OUTDOOR UNIT.....	4
ELECTRIC CONNECTION.....	8
ELECTRIC WIRE DIAGRAM.....	9
SETTING STATIC PRESSURE.....	10
STATIC-CURVE.....	10
INDOOR UNIT MAINTENANCE.....	10
CONSTRUCTION AND VENTILATION PIPELINE DESIGN SCHEME.....	12
TRIAL RUN .....	13

## 1. PRECAUTIONS

Precautions before reading the installation manual.

- Read this user manual carefully before installing the equipment.
- The air conditioner must be installed by professional technicians.
- When installing the indoor unit and its accessory pipes, adhere to this user's manual as far as possible.
- Inspect and make sure the piping and cabling are correct before powering on the air conditioner.
- This information may change with the update of this machine, and no further notice will be given for such change.

The safety precautions listed here are divided into two categories. In either case, important safety information is listed which must be read carefully.



### WARNING

Failure to observe a warning may result in death.



### CAUTION

Failure to observe a caution may result in injury or damage to the equipment.

After completing the installation, make sure that the unit operates properly during the start-up operation. Please instruct the customer on how to operate the unit and keep it maintained. Also, inform customers that they should store this installation manual along with the owner's manual for future reference.



### WARNING

- Do not throw or slam the remote controller.
- Operate the remote controller within the receiving scope of the

indoor unit, and direct the transmitting part of the remote controller to the receiver of the indoor unit.

- The remote controller should be over 1m away from the television or sound box.
- Do not place the remote controller at a moist place, near the heat sources such as stove, or expose it directly in the sunlight.
- Ensure correct positive and negative poles when loading the batteries.
- Decide the correct way of conveying the equipment.
- Try to transport this equipment with the original package.
- If the a ir conditioner needs to be installed on a metal part of the building, electric insulation must be performed, and the installation must meet the relevant technical standards of electric devices.
- **The appliance must be installed 2.3m above floor.**
- **The appliance shall not be installed in the laundry.**
- **Before obtaining access to terminals, all supply circuits must be disconnected.**
- **The appliance must be positioned so that the plug is accessible.**
- **The enclosure of the appliance shall be marked by word, or by symbols, with the direction of the fluid flow.**
- **If the supply cord is damaged, it must be replaced by the manufacture or its service agent or a similarly qualified person in order to avoid a hazard.**
- **An all-pole disconnection switch having a contact separation of at least 3mm in all poles should be connected in fixed wiring.**
- **Power wire of air conditioner should not intersect with lightning-proof ground lead.**
- **Ensure a safety distance between Air conditioner device and lightning-proof device should be more than 3 meters**
- **In the area that is vulnerable to lightning and rain, we suggest install a proper lightning protector in front of the power wire of air conditioner equipment.**



### CAUTION

- Install the unit where enough space of installation and maintenance is available.
- Install the unit where the ceiling is horizontal and enough for bearing the weight of the indoor unit.
- Install the unit where the air inlet and outlet are not baffled and are the least affected by external air.
- Install the unit where the supply air flow can be sent to all parts in the room.
- Install the unit where it is easy to lead out the connective pipe and the drain pipe.
- Install the unit where no heat is emitted from a heat source directly.
- Installing the equipment in any of the following places may lead to faults of the equipment (if that is inevitable, consult the supplier):

- The site contains mineral oils such as cutting lubricant.
  - Seaside where the air contains much salt.
  - Hotpring area where corrosive gases exist, e.g., sulfide gas.
  - Factories where the supply voltage fluctuates seriously.
  - Inside a car or cabin.
  - Place like kitchen where oil permeates.
  - Place where strong electromagnetic waves exist.
  - Place where flammable gases or materials exist.
  - Place where acid or alkali gases evaporate.
  - Other special environments.
- Install the unit where enough space of installation and maintenance is available.
  - Install the unit where the air inlet and air outlet are free from obstacles and strong wind.
  - Install the unit in a dry and well ventilated place.
  - Install the unit where the bearing surface is level and can bear weight of the unit, and is suitable for installing the unit horizontally without increasing noise or vibration.
  - Install the unit where the operation noise and the expelling of air do not affect neighbours.
  - Install the unit where no flammable gas is leaked.
  - Install the unit where it is convenient for pipe connection and electric connection.
- Refrigerant Piping
    - Piping kit used for the conventional refrigerant cannot be used.
    - Use copper pipe with 0.8 mm or more thickness for  $\phi 9.5\text{mm}$ .
    - Use copper pipe with 1.0 mm or more thickness for  $\phi 15.9\text{mm}$ .
    - Use copper pipe with 1.0 mm or more thickness for  $\phi 19.0\text{mm}$ .
    - Use copper pipe with 1.0 mm or more thickness for  $\phi 22.0\text{mm}$ .
    - Use copper pipe with 1.0 mm or more thickness for  $\phi 25.0\text{mm}$ .
    - Use copper pipe with 1.0 mm or more thickness for  $\phi 28.0\text{mm}$ .
    - Flare nut and flare works are also different form those of the conventional refrigerant. take out the flare nut attached to the main unit of the air conditioner, and use it.
  - Before installation
    - Be careful to the following items before installation.
  - Air purge
    - For air purge, use a vacuum pump.
    - Do not use refrigerant charged in the outdoor unit for air purge. (The refrigerant for air purge is not contained in the outdoor unit.)
  - Electrical cabling
    - Be sure to fix the power cables and indoor/outdoor connecting cables with clamps so that they do not contact with the cabinet, etc.
  - Installation Place
    - A place which provides a specified space around the outdoor unit.
    - A place where the operation noise and discharged air are not given to your neighbors.
    - A place that is not exposed to a strong wind.
    - A place that does not block a passage.
    - When the outdoor unit is installed in an elevated position, make sure it's four feet securely installed.
    - There must be sufficient space for carrying in the unit.
    - A place where the drain water does not make any problem.
  - Required tools for installation work
    - 1) Phillips screw driver
    - 2) Hole core drill(65mm)
    - 3) Spanner
    - 4) Pipe cutter
    - 5) Knife
    - 6) Reamer
    - 7) Gas leak detector
    - 8) Tape measure
    - 9) Thermometer
    - 10) Mega-tester
    - 11) Electro circuit tester
    - 12) Hexagonal wrench

- 13) Flare tool
- 14) Pipe bender
- 15) Level vial
- 16) Metal saw
- 17) Gauge manifold (Charge hose:R410A special requirement)
- 18) Vacuum pump (Charge hose:R410A special requirement)
- 19) Torque wrench
  - 1/4(17mm)16N•m (1.6kgf•m)
  - 3/8(22mm)42N•m (4.2kgf•m)
  - 1/2(26mm)55N•m (5.5kgf•m)
  - 5/8(15.9mm)120N•m (12.0kgf•m)
- 20) Copper pipe gauge adjusting projection margin
- 21) Vacuum pump adapter

## 2. ACCESSORIES



### NOTE

- If in the wire control mode, the accessories do not include display panel assembly remote controller or mounting bracket.

Table 2-1

Accessory name of indoor unit	Qty.	Shape	Purpose
Owner's manual	1		_____
Installation manual	1		This manual
Sealing tape	1		Sealed tube interface
Water connective pipe	2		Connect to water drainage pipe
Protective sleeve for refrigerant inlet and outlet pipes	2		_____
Wired remote controller	1		_____
Copper nut	1		Connect to liquid-side pipe
Water outlet connection pipe	1		Centralized drainage
Straight screwdriver	1		Inspection and DIP
Sealing ring	1		Centralized drainage
Waterproof chassis cover	2		Chassis auxiliary drainage plug

Table 2-2

Accessory name of outdoor unit	Qty.	Shape	Purpose
Connection pipe	1		Connecting pipe of system
Curved connection pipe	1		

### 3. INSTALLATING INDOOR UNIT

#### 3.1 Installation Space (Unit:mm)

Ensure enough space required for installation and maintenance.

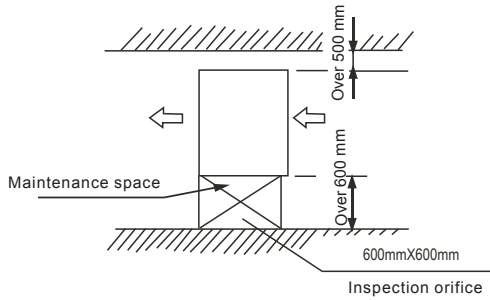

Fig. 3-1

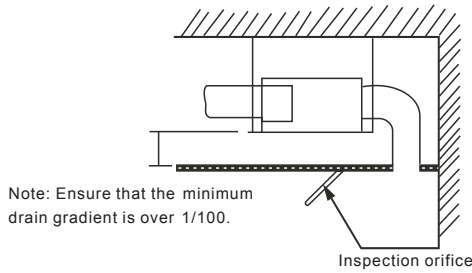

Fig. 3-2

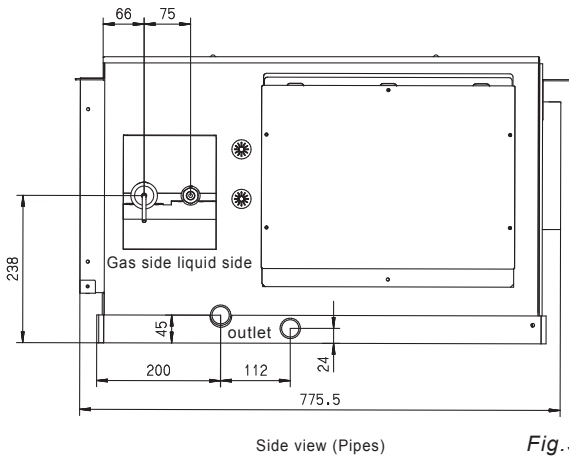
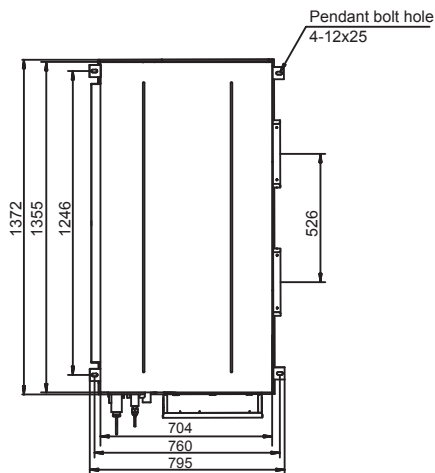

Fig. 3-3

#### 3.2 Install $\Phi 10$ Pendant Bolts Or Ground Bolts



(Unit:mm)  
Fig. 3-4

- Use  $\Phi 10$  or bigger screws. The screw material is high-quality carbon steel (whose surface is zinc plated or undergoes other rustproof treatment) or stainless steel.
- The treatment of the ceiling varies between buildings. For detailed measures, consult with the fitting-out staff.

- Fix the pendant bolts firmly and reliably in light of the specific situation.
- Installation of the pendant bolt in different environments.

##### A. Wooden structure

Put rectangular sticks across the beams, and set pendant bolts.

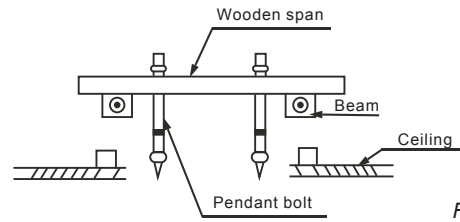

Fig. 3-5

##### B. New concrete roughcast

Use embedded bolts, embedded pulling plugs, and embedded stick harness.

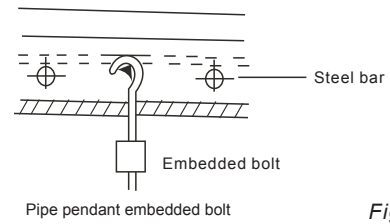

Fig. 3-6

##### C. New concrete roughcast

Set it with embedded bushes or embedded bolts.

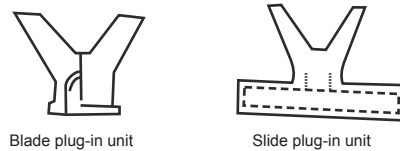

Fig. 3-7

##### D. Steel beam and girder structure

Set and use supportive angle steel.

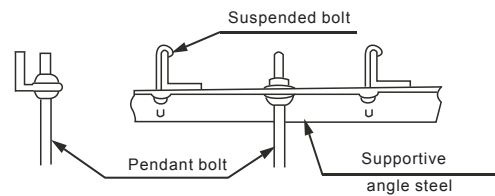

Fig. 3-8

#### 3.3 Suspending The Indoor Unit

Use a hoisting device to hoist the indoor unit, align it with the installation screw, adjust the horizontality and then tighten it.

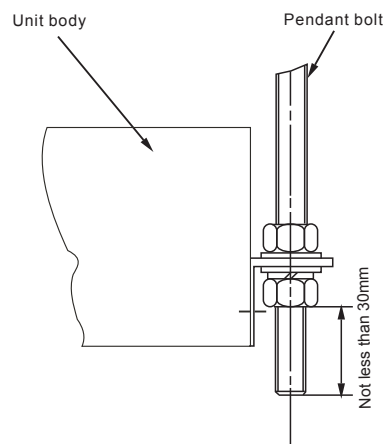

Fig. 3-9

### 3.4 Design And Connection Of Duct

- The duct design must comply with the national heating air conditioner pipeline design specifications.
- The duct accessories and materials must be produced by professional manufacturers.
- In order to prevent air flow shorting, do not keep the air inlet pipe near the air outlet pipe.
- Install a filter at an easy-to-maintain place such as intake pipe. (Otherwise, the duct will gather on the air heat exchanger and lead to fault and water leak of the air conditioner.)
- In order to suppress noise effectively, install noise suppression and sound insulation devices, especially in the noise-sensitive spaces such as meeting rooms.
- For connection of the flange plane, use non-flammable canvas adapter to prevent transmission of vibration. For its size, see the indoor unit outline diagram. Use M6X20 screws (configured on site) for connection.
- All pipelines must be connected closely and soundly without leak of air. The pipelines must be adiabatic and free from condensation.

Key points of duct connection

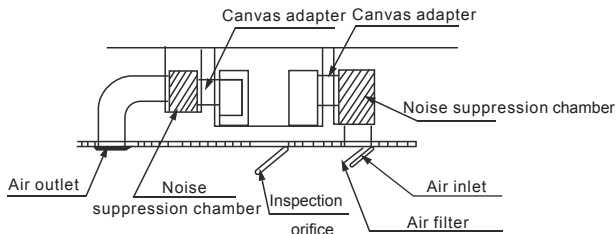

Fig.3-10

### 3.5 Install the drainpipe

#### 1. Install the indoor unit drainpipe

Install a drain stream trap in the drainpipe to prevent water from overflowing. (The drainpipe absorbs the odor. When the outside static pressure is high (especially the air inlet), it is difficult to drain the water.)

Drainage should be natural. When constructing, the outside pipe of outdoor unit should be inclined (1/50~1/100).

The bending part of drainpipe should be fewer than 2. Furthermore, to reduce the depositing dust, avoid bending the pipe as possible as you can.

Make sure there is no dust or rubbish falling into indoor unit drain elbow and drainpipe.

After installation, remove the checking panel, pour some water in the drain elbow to see whether it drains smoothly.

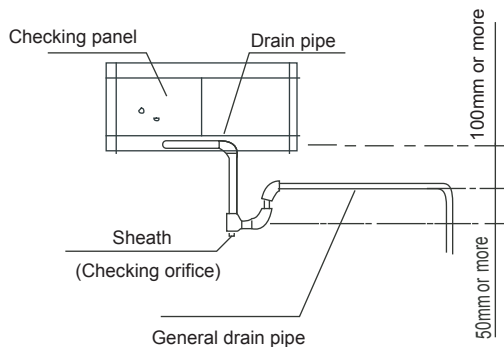

Fig.3-11



### CAUTION

Rubbish is easy to accumulate at drain stream trap. Make sure to install a plug or other things which is easy to clean.

#### 2. Test draining

Open the clapboard of indoor unit, pour the water in to see whether it drain smoothly and whether there is water leakage.

#### 3. Heat insulation

After confirming that drainage is smoothly and there is no leakage, wrap the drainpipe with insulation material, or there will be condensed water.

### 3.6 Dimension (Unit:mm)

- MHC-96HWD1N1(A)

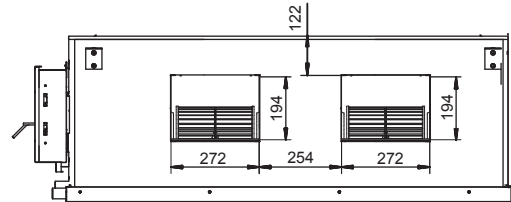

Fig.3-12

Air outlet duct connection screw hole location diagram

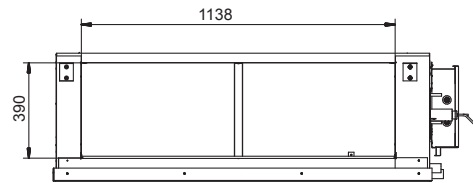

Fig.3-13

Return air duct rivet screw hole location diagram

## 4. INSTALLATION OUTDOOR UNIT

### 4.1 Transportation

- Handling of the unit

The angle of inclination should not be more than 15° when carrying the unit, to avoid overturn of the unit.

a. Rolling handling: several rolling rods of the same size are placed under the base of the unit, and the length of each rod must be more than the outer frame of the base and suitable for balancing of the unit.

b. Lifting: the strength lifting rope (belt) can bear should be 4 times the weight of the unit. Check the lifting hook and ensure that it is firmly attached to the unit, and the lifting angle should be more than 60°. Any person is not allowed to stand below the unit when lifting it.

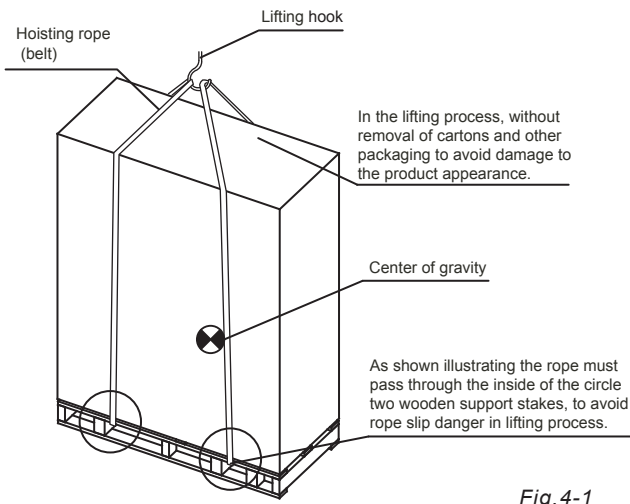

Fig.4-1

## 4.2 Installation place

Please keep away from the following place, or malfunction of the machine may be caused:

- There is combustible gas leakage.
- There is much oil (including engine oil) ingredient.
- There is salty air surrounding(near the coast)
- There is caustic gas (the sulfide, for example) existing in the air (near a hot spring)
- A place the heat air expelled out from the outdoor unit can reach your neighbor's window.
- A place that the noise interferes your neighbors every day life.
- A place that is too weak to bear the weight of the unit
- Uneven place.
- Insufficient ventilation place.
- Near a private power station or high Frequency equipment.
- Install indoor unit, outdoor unit, power cord and connecting wire at least 1m away from TV set or radio to prevent noise or picture interference.

The insulation of the metal parts of the building and the air conditioner should comply with the regulation of National Electric Standard.



### CAUTION

Keep indoor unit, outdoor unit, power supply wiring and transmission wiring at least 1 meter away from televisions and radios. This is to prevent image interference and noise in those electrical appliances. (Noise may be generated depending on the conditions under which the electric wave is generated, even if 1 meter is kept.)

## 4.3 Installation space (Unit:mm)

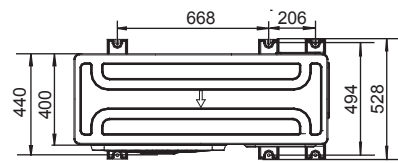
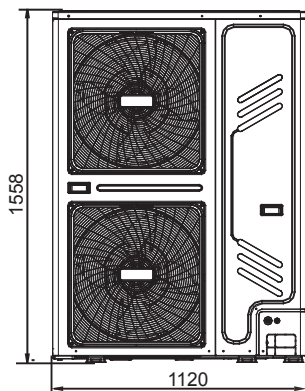

Fig.4-2

- Single unit installation

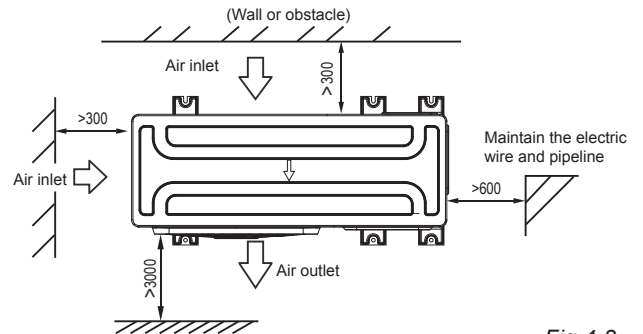

Fig.4-3

- Parallel connect the two units or above

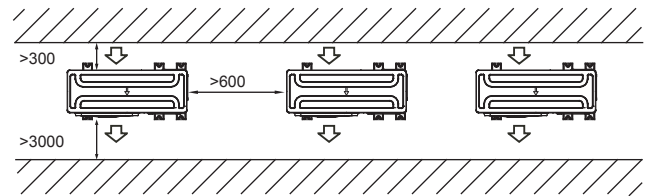

Fig.4-4

- Parallel connect the front with rear sides

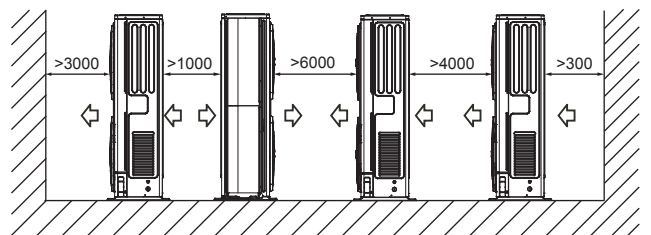
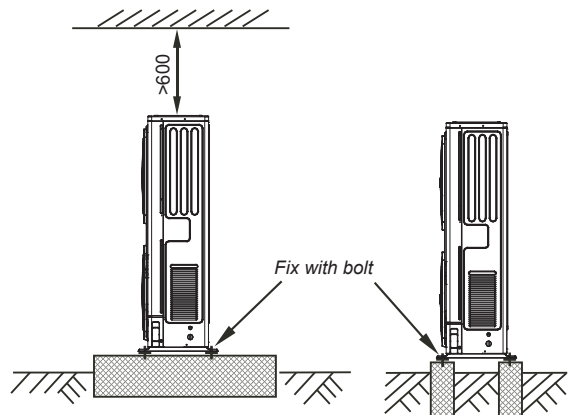

Fig.4-5

## 4.4 Moving and installation

- Since the gravity center of the unit is not at its physical center, so please be careful when lifting it with a sling.
- Never hold the inlet of the outdoor unit to prevent it from deforming.
- Do not touch the fan with hands or other objects.
- Do not lean it more than 45°, and do not lay it sidelong.
- Make concrete foundation according to the specifications of the outdoor units.(refer to Fig.4-6)
- Fasten the feet of this unit with bolts firmly to prevent it from collapsing in case of earthquake or strong wind. (refer to Fig.4-6)



(Unit:mm)

Fig.4-6



## NOTE

All the pictures in this manual are for explanation purpose only. They may be slightly different from the air conditioner you purchased(depend on model).The actual shape shall prevail.

### 4.5 Centralized Chassis Drainage

When the outdoor unit requires centralized drainage, install the chassis and two waterproof covers for the chassis, as shown in Figure 4-7. Install the water outlet union pipe and sealing ring on the chassis, and then connect the drainage pipe to complete centralized drainage installation.

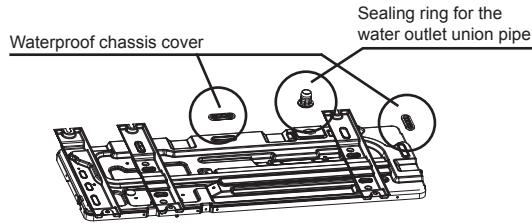

Fig.4-7



## CAUTION

While installing the outdoor unit, pay attention to the installation place and the drainage pattern;  
if it's installed at the alpine zone, the frozen condensed water will block up the water outlet, please pull out the rubber stopper of the reserve water outlet. If that still fails to satisfy for the water draining, please knock open the other two water outlets, and keep the water can drain in time.  
Pay attention to the knock the reserve water outlet from outside to inside, and it will be beyond repair after knocking open, please pay attention to the installation place, lest cause the inconvenience.  
Please do the moth proofing for the knocked out hole, to avoid the pest processing into and destroy the components.

### 4.6 Install The Connecting Pipe Of Outdoor Unit

Check whether the height drop between the indoor unit and outdoor unit, the length of refrigerant pipe, and the number of the bends meet the following requirements:

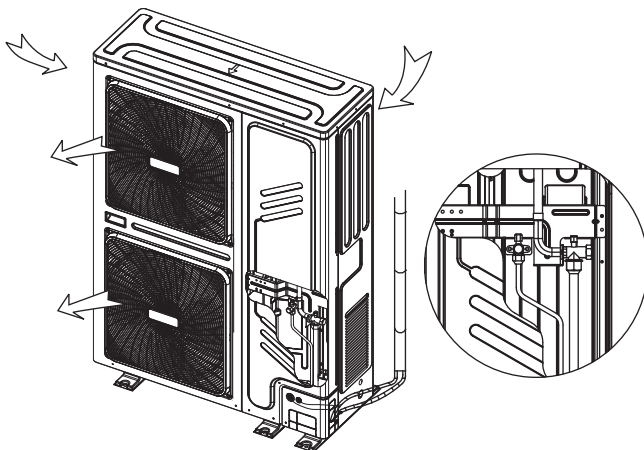

Fig.4-8



## CAUTION

Please pay attention to avoid the components while connect to the connecting pipes.  
To prevent the refrigerant piping from oxidizing inside when welding, it is necessary to charge nitrogen, or oxide will chock the circulation system.

### The indoor and outdoor connecting pipe interface and power line outlet

Vavious piping and viring patterns can be selected,such as out from the front ,the back the side ,and undersurface, etc. (The follow display the locations of several piping and wiring knock-off interfaces)

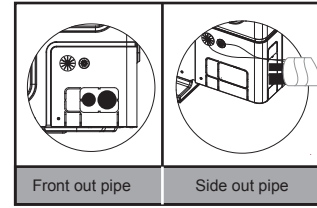

Fig.4-9



## CAUTION

1. Side out pipe: cut the side hole of the pipe-outlet plate selectively. It is suggested to cut a piece of metal plate below to avoid the mouse come and destroy the machine wiring body.
2. Front out pipe: cut the frontal hole of the pipe-outlet plate selectively. It is suggested to cut a piece of metal plate right side to avoid the mouse come and destroy the machine wiring body.
3. Wiring of power cord: the strong and weak electrical wire should be out through the two plastic holes of the pipe-outlet plate, and binded with gas and liquid pipe together.

### 4.7 Leak Detection

Use soap water or leak detector to check every joint whether leak or not (Refer to Fig.4-10).Note:

A is low pressure side stop valve

B is high pressure side stop valve

C and D is connecting pipes interface of indoor and outdoor units

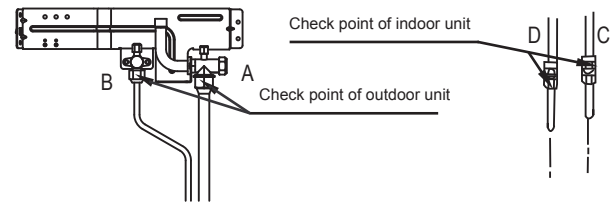

Fig.4-10

### 4.8 Heat Insulation

Do the heat insulation to the pipes of air side and liquid side separately. The temperature of the pipes of air side and liquid side when cooling, for avoiding condensation please do the heat insulation fully.

■ The air side pipe should use closed cell foamed insulation material, which the fire-retardant is B1 grade and the heat resistance over 120°C.

■ When the external diameter of copper pipe  $\leq \Phi 12.7\text{mm}$ , the thickness of the insulating layer at least more than 15mm;

When the external diameter of copper pipe  $\geq \Phi 15.9\text{mm}$ , the thickness of the insulating layer at least more than 20mm.

■ Please use attached heat-insulating materials do the heat insulation without clearance for the connecting parts of the indoor unit pipes.

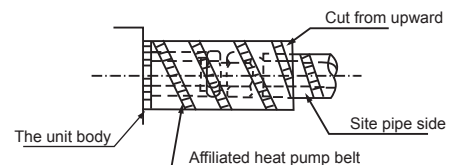

Fig.4-11



## 4.9 Size Of Outdoor Unit Pipes And Piping Methods

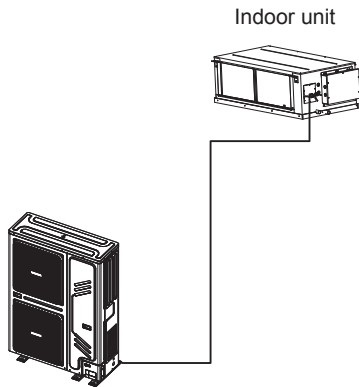

Fig. 4-12

- Size of outdoor unit pipes and piping methods

Table.4-1

Model	Gas side	Liquid side
MOUA-96HD1N1-R	φ25.4mm	φ9.5mm
MHC-96HWD1N1(A)	φ25.4mm	φ9.5mm

- Allowed length of refrigerant pipe and height difference

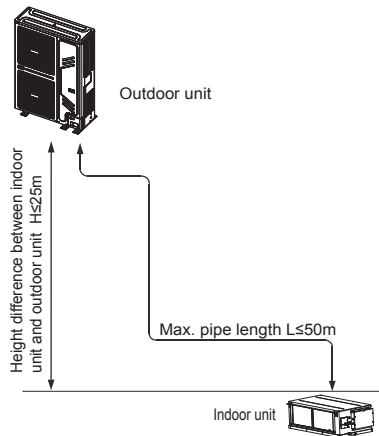

Fig. 4-13

Table.4-2

			Allowed value
Max. actual length of pipe (L)			50m
Max. height difference	Height difference between indoor unit and outdoor unit (H)	Outdoor (upper)	25m
		Outdoor (lower)	30m

## 4.10 Remove Dirt or Water in the Piping

Make sure there is no any dirt or water before connecting the piping to the outdoor units.

Wash the piping with high pressure nitrogen, never use refrigerant of outdoor unit.

## 4.11 Airtight Test

Charge pressured nitrogen after connecting indoor/outdoor unit piping to do airtight test.



### NOTE

- Pressured nitrogen [ 4.3MPa (44kg/cm<sup>2</sup>) for R410A] should be used in the airtight test.
- Tighten high pressure/low pressure valves before applying pressured nitrogen.
- Apply pressure from air vent mouth on the high pressure/low pressure valves.
- The high pressure/low pressure valves are closed when applying pressured nitrogen.
- The airtight test should never use any oxygen, flammable gas or poisonous gas.

## 4.12 Air Purge with Vacuum Pump

- Using vacuum pump to do the vacuum, never using refrigerant to expel the air.
- Vacuuming should be done from both liquid side and gas side simultaneously.
- Open all valves.

## 4.13 Refrigerant Replenishment Quantity

- For one-way pipe whose length is no longer than 5m, please refer to nameplate for refrigerant filling amount. No extra refrigerant is needed.
- One-way pipe whose length is longer than 5m, additional refrigerant quantity should be calculated by pipe diameter and length of outdoor and indoor unit liquid side pipe. For details, please refer to table.4-3.

Table.4-3

Diameter of liquid-side pipe	Refrigerant replenishment quantity	Remarks
φ 9.5mm	0.030(L-5) kg	L is the length of One-way pipe

- Please record and keep the refrigerant filling amount for future use.

## 4.14 Schematic Diagram Of Connection Between Indoor Unit And Outdoor Unit

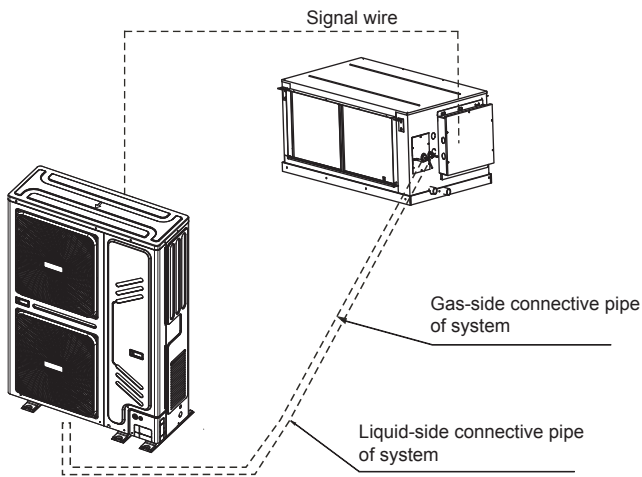

Fig.4-14

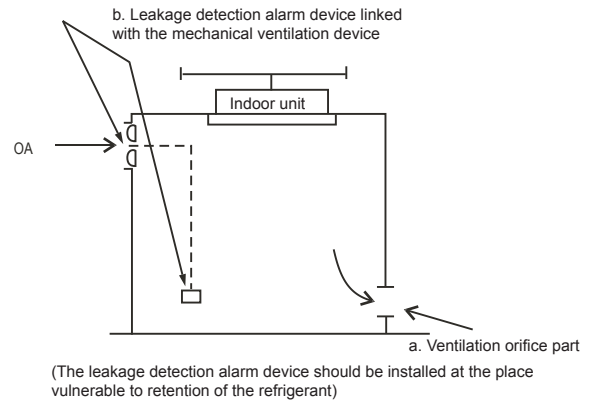

Fig.4-16

## 4.15 Refrigerant Leak Precautions

This air conditioner uses refrigerant R410A. The R410A is safe refrigerant which is harmless and non-flammable. The room for placing the air conditioner should have a proper space. Even if refrigerant leakage occurs, the density threshold will not be crossed. Additional measures may also be taken.

- Density threshold: Density of the Freon gas that does not harm the human body. Density threshold of R410A: 0.44 [ kg/m<sup>3</sup>]
- Calculate the total quantity of refrigerant to be replenished (A [kg]). Total refrigerant quantity for 10HP = refrigerant replenishment quantity upon shipment + additional refrigerant replenishment corresponding to the pipe length.
- Calculate out the indoor volume (B[m<sup>3</sup>]) (according to the minimum volume)
- Calculate out the refrigerant density:
 
$$\frac{A[\text{kg}]}{B[\text{m}^3]} \leq \text{Density threshold: } 0.44 [\text{kg}/\text{m}^3]$$
- Measures against crossing of the refrigerant density threshold
- In order to keep the refrigerant density below the threshold value, please install a mechanic ventilation device. (perform ventilation often)
- In case frequent ventilation is impossible, please install the leakage detection alarm device linked with the mechanical ventilation device.

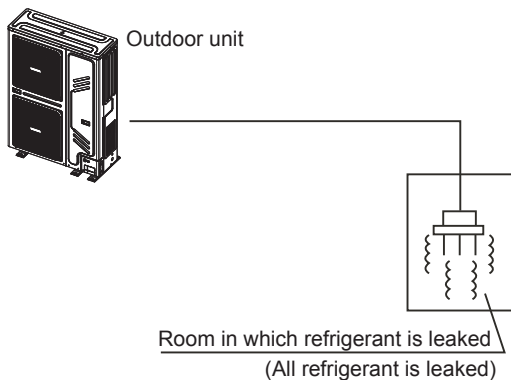

Fig.4-15

## 5. ELECTRIC CONNECTION



### CAUTION

- Use special power supply for the air conditioner. Design power supplies specific to the indoor unit and outdoor unit. The supply voltage must comply with the nominal voltage.
- The external supply circuit of the air conditioner must have a ground wire, and the power supply ground wire of the indoor unit must be connected with the external ground wire firmly.
- The wiring must be performed by professional technicians according to the circuit diagram labels.
- Distribute the wires according to the relevant electric technical standards promulgated by the State, and set the Residual Current-operated Circuit Breaker (RCCB) properly.
- The power wire and the signal wire shall be laid out neatly and properly, without mutual interference or contacting the connection pipe or valve.
- No power cable is attached to this equipment. The user can select the power cable by reference to the stipulated power supply specifications. No joint of wires is allowed.
- Upon completion of wire connection, double check it and then connect the power supply.
- An all-pole disconnection device which has at least 3mm separation distance in all pole and a residual current device(RCD)with the rating of above 10mA shall be incorporated in the fixed wiring according to the national rule.
- The appliance shall be installed in accordance with national wiring regulations.

■ Specifications of power supply

Table.5-1

	Indoor unit	Outdoor unit
Model	MHC-96HWD1N1(A)	MOUA-96HD1N1-R
Power	220-240V~ 50Hz	380-415V 3N~ 50Hz
Switch capacity of the main power supply/fuse(A)	16/16	40/40
Indoor unit power cable(mm <sup>2</sup> ) includes grounded wire	3×2.5 mm <sup>2</sup>	———
Outdoor unit power cable(mm <sup>2</sup> ) includes grounded wire	———	5×6.0 mm <sup>2</sup>
Indoor Unit /Outdoor Unit Signal Wire (mm <sup>2</sup> ) (Weak electric signal)	3-core shielded wire 3X0.75	

■ The power cord type designation is H05RN-R or above/H07RN-F.

## 6. ELECTRIC WIRE DIAGRAM

■ MHC-96HWD1N1(A)

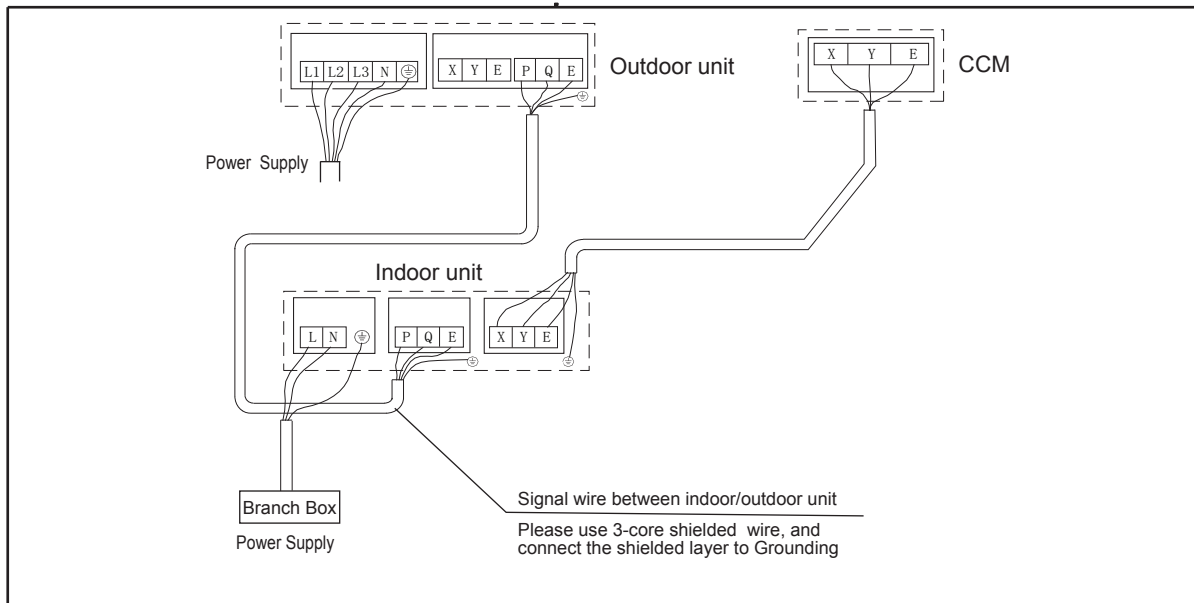

Fig. 6-1

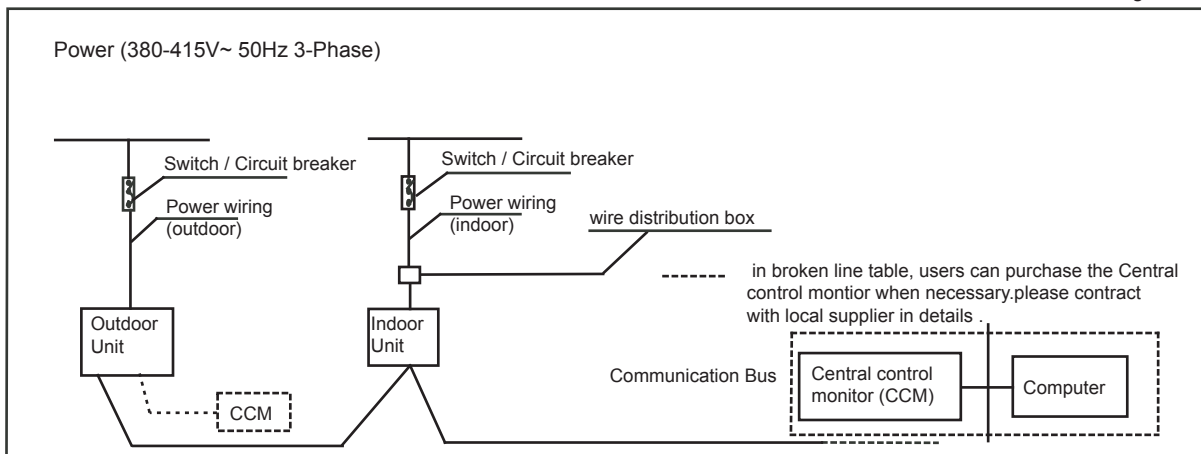

Fig. 6-2

This wire diagram is applicable to both cooling and heating model.



## NOTE

- Pay attention to the phase sequence of the power supply. If the phase sequence is reversed, the compressor will not start. Meanwhile, the fault indicator of the outdoor electric control board will light up. For details, see Outdoor unit wiring diagram on the cover plate of the electric control box.
- After shifting the phase sequence, power on the unit until the fault indicator goes out and the compressor starts up normally.
- If the supply cord is damaged, it must be replaced by the manufacturer or its service agent or a similarly qualified person in order to avoid a hazard.
- An all-pole disconnection switch having a contact separation of at least 3mm in all poles should be connected in fixed wiring.
- The appliance shall be installed in accordance with national wiring regulations.
- The temperature of refrigerant circuit will be high, please keep the interconnection cable away from the copper tube.

## 7. SETTING STATIC PRESSURE

The corresponding table of electronic control dial code and static pressure range is shown in table 7-1.

Table 7-1

For Setting Static pressure				
ENC2				
Code	0	1	2	3
High static pressure	0~50	51~80	81~120	121~150
Factory Setting	✓			



## CAUTION

- Before starting the operation, the installer must set the electronic control dial code based on the actual value of the static pressure of the product. Otherwise, there will be problems.

## 8. STATIC-CURVE

MHC-96HWD1N1(A)

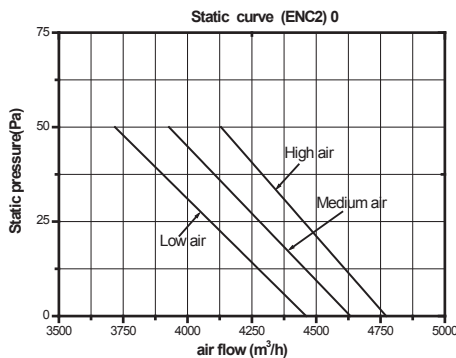

Fig. 8-1

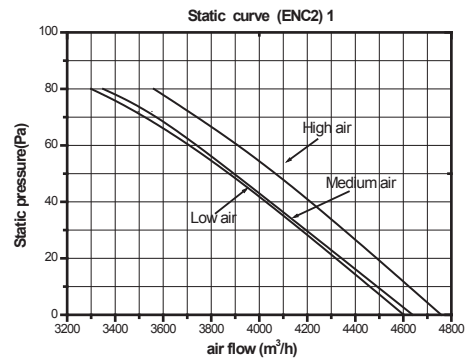

Fig. 8-2

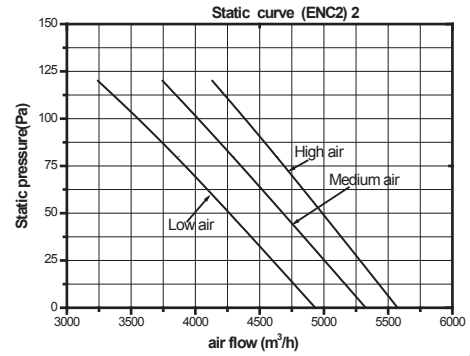

Fig. 8-3

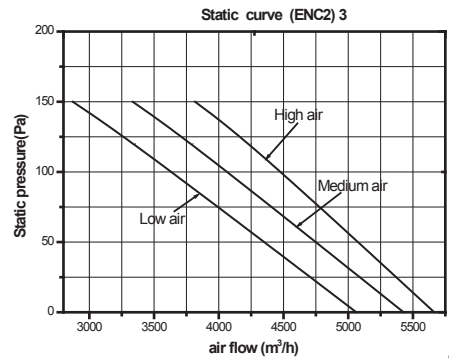

Fig. 8-4

## 9. INDOOR UNIT MAINTENANCE

For convenient repairing and maintenance, the reserved inspection orifice should larger than the base of the indoor unit and the connecting duct is detachable. When remove the base of air conditioner and the fan motor assembly which are very heavy, it is necessary that two persons do it together.

### 9.1 Steps to remove the fan motor assembly

- 1) Remove the screws around the base of air conditioner till the base can be removed. (Fig.9-1,9-2)
- 2) Neaten the wires of motor; only remove the wires of motor from connector.
- 3) Remove the detachable duct, and move away.
- 4) Move away 4 pieces of M8 screws from the front board of air conditioner. (Fig.9-3)
- 5) Support the bottom of the fan motor assembly by hand, then push it up. It needs two persons to do. When the hole on clapboard of fan assembly is higher than the pin on front board (Fig.9-4), push the fan motor assembly back about 21mm (Fig.9-5) to make the hole separate from the pin. Hold the assembly and slowly draw it down along the guide rail (Fig.9-6), and then the assembly can be taken out for maintenance and repairing.

## 9.2 Steps to install the fan motor assembly

- 1) Lift the fan motor assembly; make the edges of fan motor assembly touch the guide rails. It needs to two persons. (Fig.9-7)
- 2) Hold the bottom of the assembly, and then push it up along the guide rails. (Fig.9-8)
- 3) Once the hole on the fan clapboard is higher than the pin on the front board, move the assembly to make the pin through the hole. (Fig.9-9)
- 4) One person supports the bottom of fan motor assembly; another one fixes the M8 screws to make the assembly fixed on the front board. (Fig.9-10)
- 5) Connect the wires of motor and neaten it.
- 6) Two persons lift the base of air conditioner, horizontally push it and make it covered the air conditioner. (Fig.9-11)
- 7) Install the duct well. (Fig.9-12)

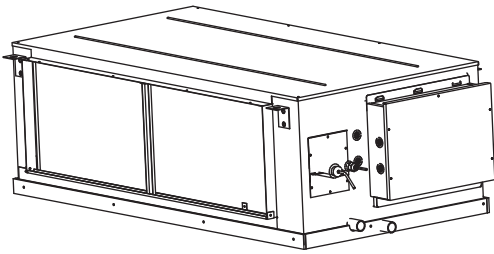

Fig.9-1

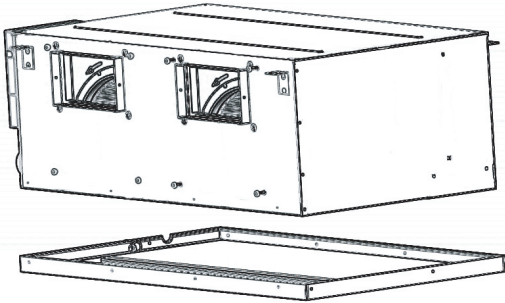

Fig.9-2

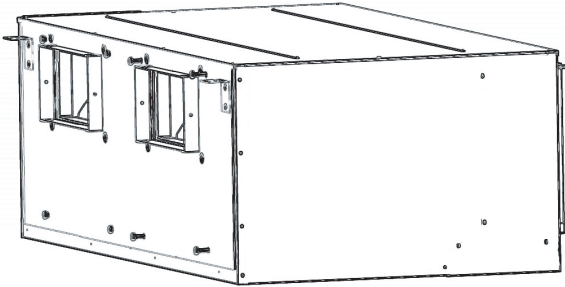

Fig.9-3

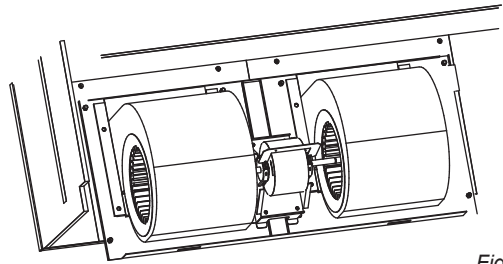

Fig.9-7

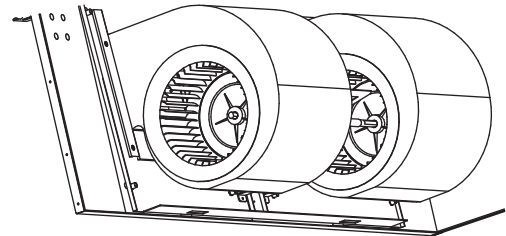

Fig.9-8

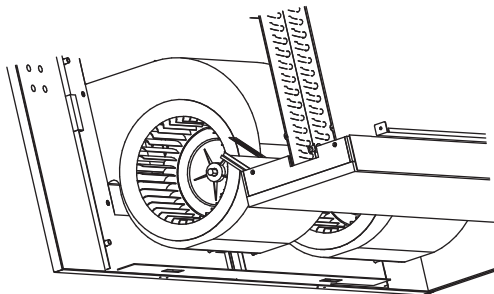

Fig.9-4

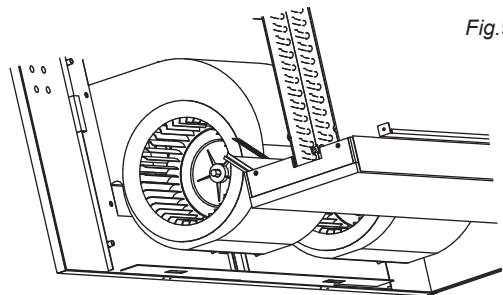

Fig.9-9

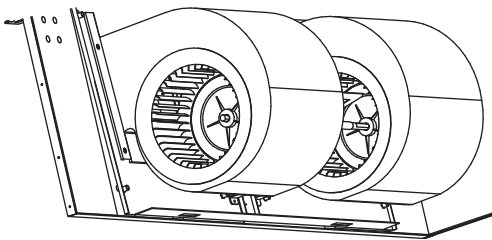

Fig.9-5

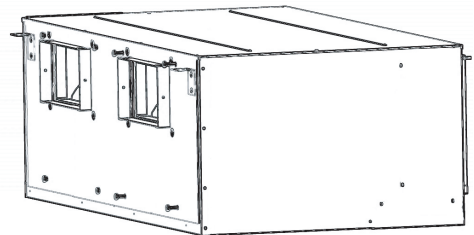

Fig.9-10

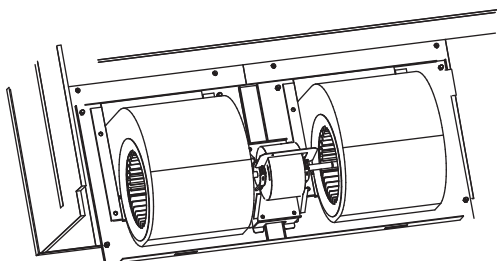

Fig.9-6

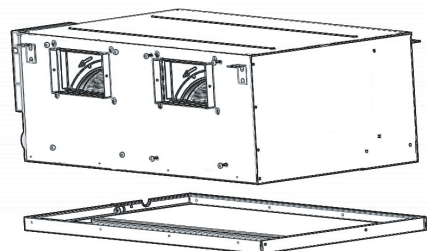

Fig.9-11

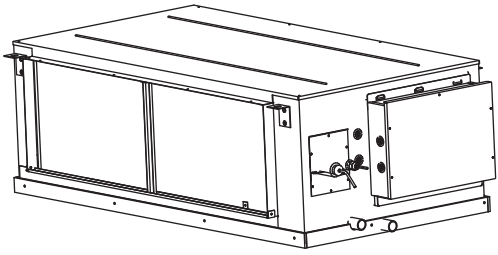
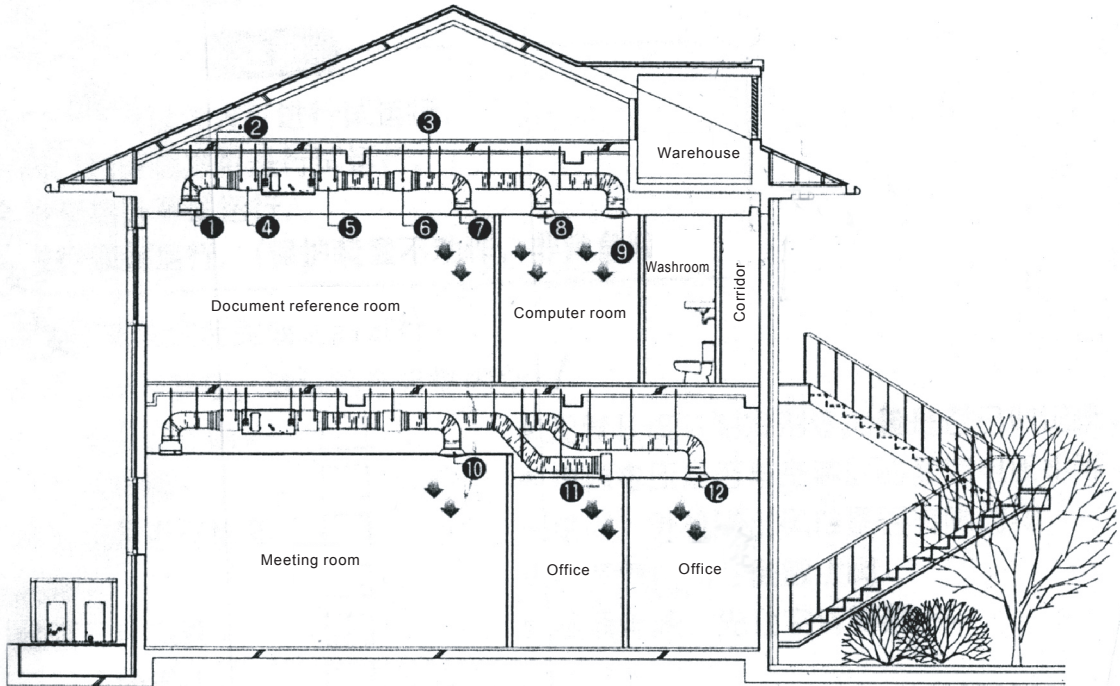

Fig.9-12

## 10. CONSTRUCTION AND VENTILATION PIPELINE DESIGN SCHEME

- Examples of construction and ventilation pipeline design scheme(Flowering hidden series)



- Construction and ventilation pipeline design scheme

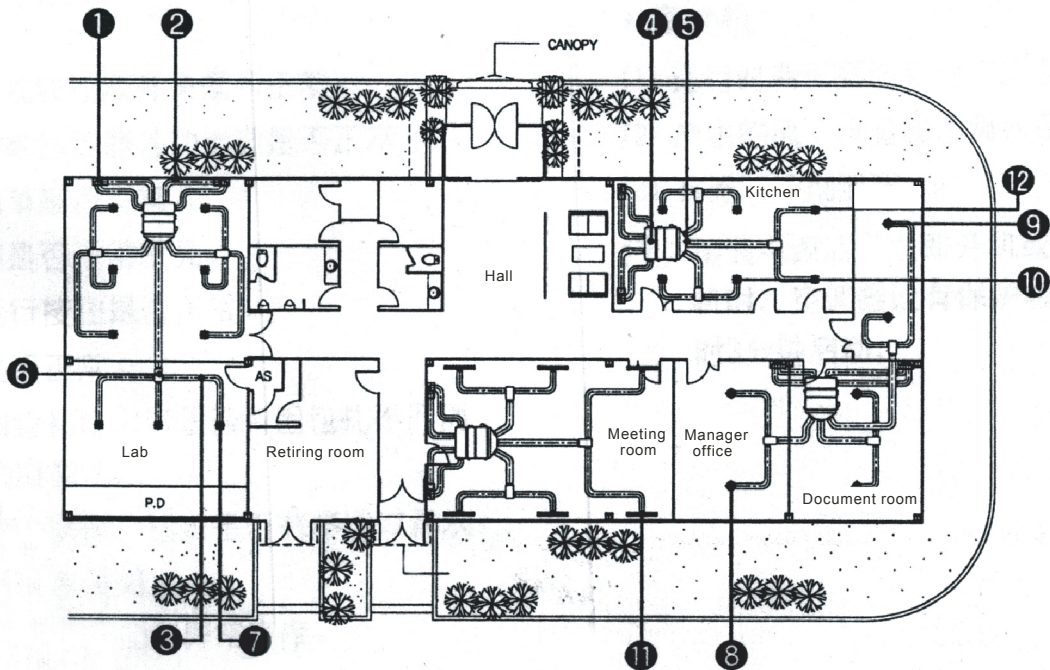

# 11. TRIAL RUN

Please conduct in accordance with "Trial Run Tenor Nameplate" on the electric control box.



## CAUTION

- Perform the trial run only after the outdoor unit has been powered on for over 12 hours.
- Check that all valves are opened before trial run.
- Check the electric safety before trial run.
- Do not perform compulsory operation in any way.(It is very dangerous if the protection device is not active)

- Perform trial run only after all installations are finished.
- Confirm the following issues before trial operation, and ✓ the box for the confirmed items.

- Check whether the indoor unit and the outdoor are installed properly.
- Check whether the piping and wiring are correct.
- Check whether the refrigerant pipeline system is inspected for leakage.
- Check whether the drain is smooth.
- Check whether the heat insulation is perfect.
- Check whether the ground cables are connected correctly.
- Check whether the pipe length and the refrigerant amount are recorded.
- Check whether the supply voltage is equal to the rated voltage of the air conditioner.
- Check whether any obstacles exist at the air inlet/outlet of the indoor or outdoor unit.
- Open the gas valve and the liquid valve.
- Connect the power supply to preheat the air conditioner.

- Install the remote controller holder as required by the user. The holder must be installed in a location suitable for transmitting the signals of the remote controller to the indoor unit.

- Trial run  
Use the remote controller or wire controller (matched) to let the air conditioner run in the cooling mode. Inspect the following items against the operation manual. (If any fault occurs, remove the fault by reference to the Section headed "Faults of Air Conditioner and Causes" in the Operation Manual.)

- Indoor unit
  - Check whether the switch of the remote controller or wire controller is normal.
  - Check whether the functional keys of the remote controller or wire controller are normal.
  - Check whether the indoor temperature conditioning is normal.
  - Check whether the indicators illuminate normally.
  - Check whether the manual operation buttons are normal.
  - Check whether the drain function is normal.
  - Check whether the connective copper pipes and the drain pipes generate condensate due to loose wrapping.
  - Open the air inlet grille to check whether any penetration or leak of water occurs, especially at the drain stopper.
  - Check whether any vibration or abnormal sound occurs during the operation.
  - Test whether the unit works normally in the heating mode.
- Outdoor unit
  - Check whether any vibration or abnormal sound occurs during the operation.
  - Check whether the air, noise and condensate generated by the unit affect the neighbors.
  - Check whether any refrigerant is leaked.

### 11.1 Important information for the used refrigerant

This product has the fluorinated gas which is listed in kyoto protocol it is forbidden to release to air.

Refrigerant type: R410A; Volume of GWP: 2088;  
GWP=Global Warming Potential

Model	Factory charge	
	Refrigerant/kg	tonnes CO <sub>2</sub> equivalent
MOUA-96HD1N1-R	7.20	15.03

#### Attention:

#### Frequency of Refrigerant Leak Checks

- 1) For equipment that contains fluorinated greenhouse gases in quantities of 5 tonnes of CO<sub>2</sub> equivalent or more, but of less than 50 tonnes of CO<sub>2</sub> equipment, at least every 12 months, or where a leakage detection system is installed, at least every 24 months.
- 2) For equipment that contains fluorinated greenhouse gases in quantities of 50 tonnes of CO<sub>2</sub> equivalent or more, but of less than 500 tonnes of CO<sub>2</sub> equipment, at least every six months, or where a leakage detection system is installed, at least every 12 months.
- 3) For equipment that contains fluorinated greenhouse gases in quantities of 500 tonnes of CO<sub>2</sub> equivalent or more, at least every three months, or where a leakage detection system is installed, at least every six months.
- 4) Non-hermetically sealed equipment charged with fluorinated greenhouse gases shall only be sold to the end user where evidence is provided that the installation is to be carried out by an undertaking certified person.
- 5) Only certificated person is allowed to do installation, operation and maintenance.

## 11.2 Information requirements for air-to-air conditioners

### Cooling mode:

Information requirements for air-to-air conditioners								
Model(s):MOUA-96HD1N1-R Test matching indoor units from1,Duct:MHC-96HWD1N1(A)								
Outdoor side heat exchanger of air conditioner:air								
Indoor side heat exchanger of air conditioner:air								
Type:compressor driven								
If applicable:driver of compressor:electric motor								
Item	Symbol	Value	Unit		Item	Symbol	Value	Unit
Rated cooling capacity	$P_{rated,c}$	28	kW		Seasonal space cooling energy efficiency	$\eta_{s,c}$	187.8	%
Declared cooling capacity for part load at given outdoor temperatures $T_j$ and indoor 27/19°C (dry/wet bulb)					Declared energy efficiency ratio or gas utilisation efficiency/auxiliary energy factor for part load at given outdoor temperatures $T_j$			
$T_j=+35^\circ\text{C}$	$P_{dc}$	28.000	kW		$T_j=+35^\circ\text{C}$	EERd	2.13	-
$T_j=+30^\circ\text{C}$	$P_{dc}$	20.632	kW		$T_j=+30^\circ\text{C}$	EERd	3.92	-
$T_j=+25^\circ\text{C}$	$P_{dc}$	13.263	kW		$T_j=+25^\circ\text{C}$	EERd	5.57	-
$T_j=+20^\circ\text{C}$	$P_{dc}$	8.078	kW		$T_j=+20^\circ\text{C}$	EERd	7.80	-
Degradation co-efficient for air conditioners(*)								
	$C_{dc}$	0.25	-					
Power consumption in modes other than "active mode"								
Off mode	$P_{OFF}$	0.040	kW		Crankcase heater mode	$P_{CK}$	0.040	kW
Thermosat-off mode	$P_{TO}$	0	kW		Standby mode	$P_{SB}$	0.040	kW
Other items								
Capacity control	variable				For air-to-air air conditioner:air flow rate,outdoor measured	-	9800	$\text{m}^3/\text{h}$
Sound power level,outdoor	$L_{WA}$	77	dB					
GWP of the refrigerant		2088	kg CO <sub>2</sub> eq (100years)					
Contact details								
(*)If $C_{dc}$ is not determined by measurement then the default degradation coefficient of heat pumps shall be 0.25								
Where information relates to multi-split air conditioners,the test result and performance data may be obtained on the basis of performance of the outdoor unit ,with a combination of indoor unit(s) recommended by the manufacturer or importer								



**Heating mode:**

Information requirements for air-to-air conditioners								
Model(s):MOUA-96HD1N1-R Test matching indoor units from1,Duct:MHC-96HWD1N1(A)								
Outdoor side heat exchanger of air conditioner:air								
Indoor side heat exchanger of air conditioner:air								
Indication if the heater is equipped with a supplementary heater:no								
If applicable:driver of compressor:electric motor								
Parameters shall be declared for the average heating season,parameters for the warmer and colder heating seasons are optional								
Item	Symbol	Value	Unit		Item	Symbol	Value	Unit
Rated heating capacity	$P_{rated,h}$	31.5	kW		Seasonal space heating energy efficiency	$\eta_{s,h}$	136.2	%
Declared heating capacity for part load at indoor temperature 20°C and outdoor temperatures $T_j$					Declared coefficient of performance or gas utilisation efficiency/auxiliary energy factor for part load at given outdoor temperatures $T_j$			
$T_j=-7^{\circ}C$	$P_{dh}$	13.417	kW		$T_j=-7^{\circ}C$	$COP_d$	2.52	-
$T_j=+2^{\circ}C$	$P_{dh}$	8.408	kW		$T_j=+2^{\circ}C$	$COP_d$	3.34	-
$T_j=+7^{\circ}C$	$P_{dh}$	5.623	kW		$T_j=+7^{\circ}C$	$COP_d$	4.46	-
$T_j=+12^{\circ}C$	$P_{dh}$	6.496	kW		$T_j=+12^{\circ}C$	$COP_d$	5.35	-
$T_{biv}$ =bivalent temperature	$P_{dh}$	13.417	kW		$T_{biv}$ =bivalent temperature	$COP_d$	2.52	-
$T_{OL}$ =operation temperature	$P_{dh}$	11.307	kW		$T_{OL}$ =operation temperature	$COP_d$	1.88	-
Bivalent temperature	$P_{biv}$	-7	°C					
Degradation co-efficient for heat pumps(**)								
	$C_{dh}$	0.25	-					
Power consumption in modes other than "active mode"					Supplementary heater			
Off mode	$P_{OFF}$	0.040	kW		Back-up heating capacity(*)	$e_{lbu}$	0.040	kW
Thermosat-off mode	$P_{TO}$	0.040	kW		Type of energy input			
Crankcase heater mode	$P_{CK}$	0.040	kW		Standby mode	$P_{SB}$	0.040	kW
Other items								
Capacity control	variable				For air-to-air heat pump:air flow rate,outdoor measured	-	9800	m <sup>3</sup> /h
Sound power level,outdoor	$L_{WA}$	77	dB					
GWP of the refrigerant		2088	kg CO <sub>2</sub> eq (100years)					
Contact details								
(**)If $C_{dh}$ is not determined by measurement then the default degradation coefficient of heat pumps shall be 0.25								







B升级为C  
P6图4-10内外机标注错误  
封底页图号升级

D-E  
整本更改  
更改P13页  
P14\15增加Lot21参数  
封底页图号